

# electronic design

THE AUTHORITY ON  
EMERGING TECHNOLOGIES  
FOR DESIGN SOLUTIONS

12.05.13 [electronicdesign.com](http://electronicdesign.com)



**NEW  
PRODUCTS  
ADDED DAILY**

\$10.00 A Penton® Publication

Periodicals Postage Paid • USPS 100 Approved Poly

**[DIGIKEY.COM/NEW](http://DIGIKEY.COM/NEW)**

OTHER DISTRIBUTORS



# 2013 Most Preferred DISTRIBUTOR

**DIGI-KEY CORPORATION 51.3%**



Source: 2013 Distributor Customer Evaluation Study,  
North America, May 2013, UBM Electronics

1.800.344.4539  
**DIGIKEY.COM**



3 MILLION PARTS ONLINE | 650+ INDUSTRY-LEADING SUPPLIERS | 100% AUTHORIZED DISTRIBUTOR

Digi-Key is an authorized distributor for all supplier partners. New products added daily. © 2013 Digi-Key Corporation, 701 Brooks Ave. South, Thief River Falls, MN 56701, USA



Don't Miss  
**electronic  
 design's**

# 2013 ENGINEERING SALARY SURVEY

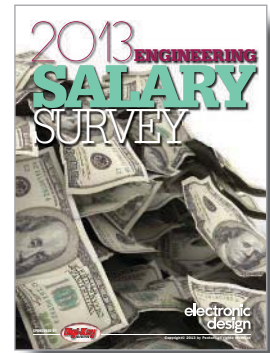

Compare your salary and work environment to other Electronic Engineers that responded to our survey and provided feedback on their jobs and industry!

## What's inside:

- 34 unique data tables, charts and infographics
- 18 pages of expert analysis and commentary covering the past, present and future of Electronic Engineer's across the United States
- In-depth coverage on: Unemployment rates, H-1B Visas, Wage stagnation, How Engineers are staying positive, Job satisfaction, How Engineers keep their skills current, Offshoring and outsourcing and more

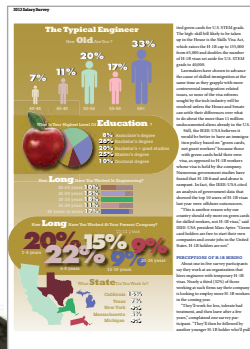

**2012 Salary Survey**

Region	Education Level	Salary Range
North	High School	\$15,000 - \$25,000
	Bachelor's	\$35,000 - \$55,000
	Master's	\$55,000 - \$75,000
	Doctorate	\$75,000 - \$100,000
South	High School	\$15,000 - \$25,000
	Bachelor's	\$35,000 - \$55,000
	Master's	\$55,000 - \$75,000
	Doctorate	\$75,000 - \$100,000
West	High School	\$15,000 - \$25,000
	Bachelor's	\$35,000 - \$55,000
	Master's	\$55,000 - \$75,000
	Doctorate	\$75,000 - \$100,000
Midwest	High School	\$15,000 - \$25,000
	Bachelor's	\$35,000 - \$55,000
	Master's	\$55,000 - \$75,000
	Doctorate	\$75,000 - \$100,000

Go to [www.electronicdesign.com](http://www.electronicdesign.com) to see more!

SPONSORED BY



**MPD**  
coin cell retainer tray



[www.batteryholders.com](http://www.batteryholders.com)

# Hard-Wired.



At Newark element14, we connect you to all of your cable and wire management needs. [newark.com](http://newark.com)

**3M**

**AlphaWire**  
Cables you trust. Service you deserve.

**Amphenol**

**BELDEN**  
SENDING ALL THE RIGHT SIGNALS

**BRADY**

**KROY**

**General Cable**

**CAROL BRAND**

**PANDUIT**

**pro-POWER**

**TE**  
connectivity

**Thomas & Betts**



**element14**



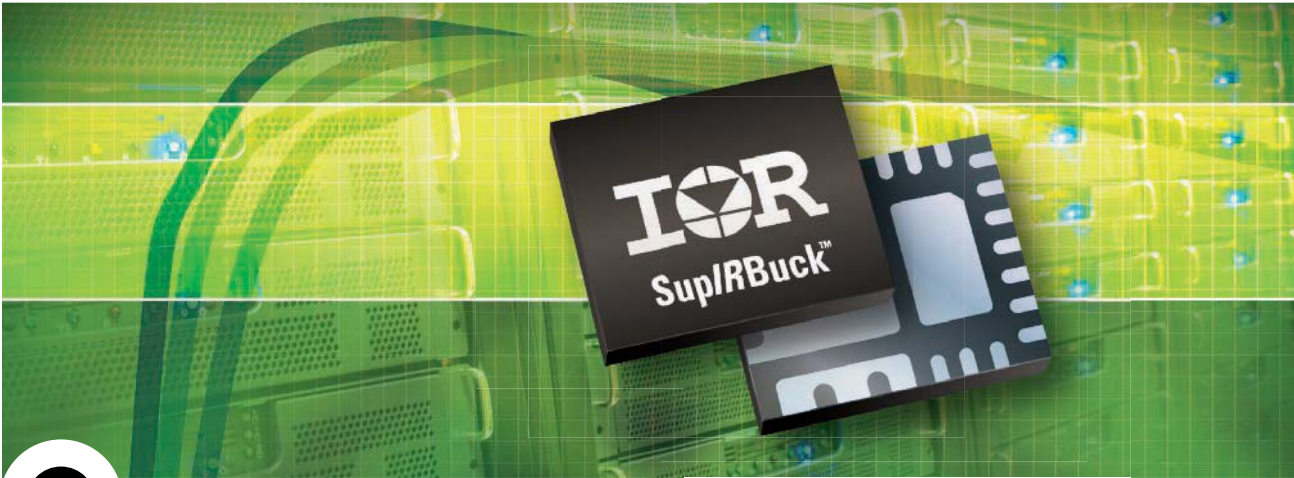

# Sup/IRBuck® Integrated Voltage Regulators

Save energy, space and system cost for your POL design

### Sup/IRBuck® Integrated Voltage Regulators

Current Rating	Single Output	Dual Output
3A	IR3823	
4A	IR3897	IR3891
6A	IR3898	
9A	IR3899	
12A	IR3894	
16A	IR3895	
25A	IR3847	

### Size(mm)

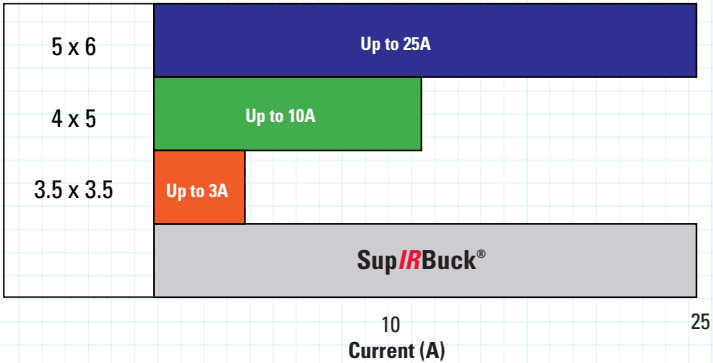

### IR Advantage

- Best-in-class efficiency over entire load range
- Common series footprint enables “cut and paste” design, and scalability allowing for faster time to market
- Integrated solution offers high power density with reduced component count and improved performance
- Single stage POL conversion saves energy, size and cost by eliminating the need for an intermediate bus
- Low profile and excellent thermal performance allows for back-side board mounting for additional space savings
- Wide input and output voltage range(s) maximizes appeal for broadest range of applications

for more information call 1.800.981.8699 or visit us at [www.irf.com](http://www.irf.com)



# In This Issue

## THE BEST TECHNOLOGIES OF 2013

- 20** CONVERTER BREAKS GROUND IN SENSING PERFORMANCE
- 22** ET BOOSTS POWER AMP LINEARITY AND EFFICIENCY
- 24** MEMORY CHANNEL STORAGE PUTS SSD NEXT TO CPU
- 26** 3D VIDEO SENSORS IMPROVE USER INTERACTIVITY
- 28** POWER CONTROLLER AND INTERFACE TRANSFORM POL REGULATION
- 30** HSA HARDWARE FRAMEWORK CHANGES CPU/GPU SOFTWARE
- 32** NEW GEAR ACCELERATES 100/400-GBIT/S OPTICAL TESTING

### COLUMNS

- 13** **EDITORIAL**  
MOOCs: The Gifts That Keep Giving
- 14** **ENERGY ZARR**  
Redefining Inductive Sensing
- 72** **LAB BENCH**  
Where Did My PC Go? It's Gone Gaming

### DISTRIBUTION RESOURCE

- 39** 5 ISSUES SHAPING THE ELECTRONICS SUPPLY CHAIN
- 39** ENERGY MARKETS STAY STRONG
- 42** NAND FLASH MEMORY MARKET DECELERATES

#### EDITORIAL MISSION:

To provide the most current, accurate, and in-depth technical coverage of the key emerging technologies that engineers need to design tomorrow's products today.

**ELECTRONIC DESIGN** (ISSN 0013-4872) is published monthly with an extra issue in June and October by Penton Media Inc., 9800 Metcalf Ave., Overland Park, KS 66212-2216. Paid rates for a one-year subscription are as follows: \$120 U.S., \$180 Canada, \$240 International. Periodicals postage paid at Shawnee Mission, KS, and additional mailing offices. Editorial and advertising addresses: ELECTRONIC DESIGN, 1166 Avenue of the Americas, New York, NY 10036. Telephone (212) 204-4200. Printed in U.S.A. Title registered in U.S. Patent Office. Copyright ©2013 by Penton Media Inc. All rights reserved. The contents of this publication may not be reproduced in whole or in part without the consent of the copyright owner. For subscriber services or to order single copies, write to Electronic Design, PO Box 2100, Skokie, IL 60076. POSTMASTER: Send change of address to Electronic Design, PO Box 2100, Skokie, IL 60076. Canadian Post Publications Mail agreement No. 40612608. Canada return address: IMEX Global Solutions, P.O. Box 25542, London, ON N6C 6B2.

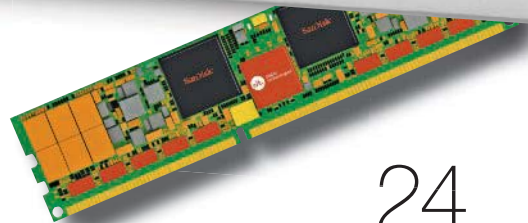



www.mouser.com

The Newest Products for Your Newest Designs®

**GO**

**M**

**mouser.com**

Manufacturers shown include: Honeywell, Honeywell, nichicon, EPCOS, TDK, VISHAY, TE connectivity, EMERSON Network Power, AVX, HRS, intel, TEXAS INSTRUMENTS, Infineon, ANALOG DEVICES, mouser, Panasonic, BOURNS, ATERA, maxim integrated, muRata, omron, ST, NXP, Amphenol, Littelfuse, International Rectifier, Atmel, OSRAM, CREE, FAIRCHILD SEMICONDUCTOR, PHOENIX CONTACT, AVAGO TECHNOLOGIES, MICROCHIP, PHILIPS LUMILEDS, ON Semiconductor, and freescale.

The **widest selection** of the **newest products**.

Over **4 million** products from over **500** manufacturers.



Authorized distributor of semiconductors and electronic components for design engineers.



**MOUSER**  
ELECTRONICS



## THE BEST IN VERTICAL MARKETS IN 2013

- 46** KICKSTARTER CHANGES HOW CONSUMER IDEAS TURN INTO GOLD
- 49** PROCESSORS BOOST MOTOR CONTROL AND PV PERFORMANCE
- 52** ULTRASOUND PLATFORM OPENS BUSINESS OPPORTUNITIES



46

## ENGINEERING HALL OF FAME

- 54** **LESTER EASTMAN:** MATERIALS PIONEER LEAVES A LEGACY OF TEACHING
- 56** **KERNIGHAN, RITCHIE, AND THOMPSON:** THE FATHERS OF C
- 58** **SHUJI NAKAMURA:** BLUE SKIES AWAIT FOR LED ILLUMINATION
- 60** **JOHN NAPIER:** LOGARITHM INVENTOR PUT RELIGION FIRST
- 63** **JOHN RENSHAW CARSON:** MODULATION'S EARLIEST INNOVATOR
- 65** **BJARNE STROUSTRUP:** C++ CREATOR KEEPS DEVELOPING THE LANGUAGE



54

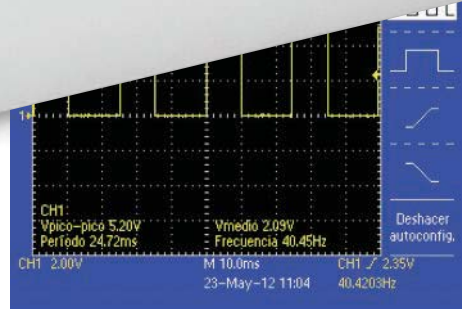

## BEST IDEA FOR DESIGN OF 2013

- 67** MICROCONTROLLER SOLVES COMPLEX TEMPERATURE POLYNOMIAL EQUATIONS



Permission is granted to users registered with the Copyright Clearance Center Inc. (CCC) to photocopy any article, with the exception of those for which separate copyright ownership is indicated on the first page of the article, provided that a base fee of \$2 per copy of the article plus \$1.00 per page is paid directly to the CCC, 222 Rosewood Drive, Danvers, MA 01923 (Code No. 0013-4872/94 \$2.00 + \$1.00). Copying done for other than personal or internal reference use without the express permission of Penton Media, Inc. is prohibited. Requests for special permission or bulk orders should be addressed to the editor. To purchase copies on microfilm, please contact National Archive Publishing Company (NAPC) at 732-302-6500 or 800-420-NAPC (6272) x6578 for further information.





## SUN-POWERED CARS CROSS AUSTRALIA IN THE WORLD SOLAR CHALLENGE

Teams from 23 countries raced their sun-powered cars on a 3000-km course across the Outback.

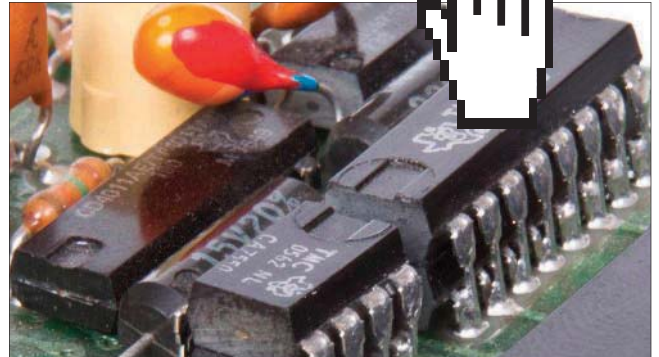

## PACKAGING: A 30-YEAR CAREER RETROSPECTIVE



We've come a long way from the first IC, but we still have a long way yet to go to achieve the full promise of the IC revolution.

## blogs

**PAUL WHYTOCK**  
ELECTRONIC DESIGN  
EUROPE



- Low-Energy Bluetooth And Ant+ Merge Onto One Chip

**DON TUITE**  
ANALOG/POWER



- Elon Musk's Hyperloop And LIM Trains

**LOUIS FRENZEL**  
COMMUNICATIONS



- Amazing, Adaptable AM Radio

**BILL WONG**  
EMBEDDED/SYSTEMS/  
SOFTWARE



- The Internet Of Thingamajigs

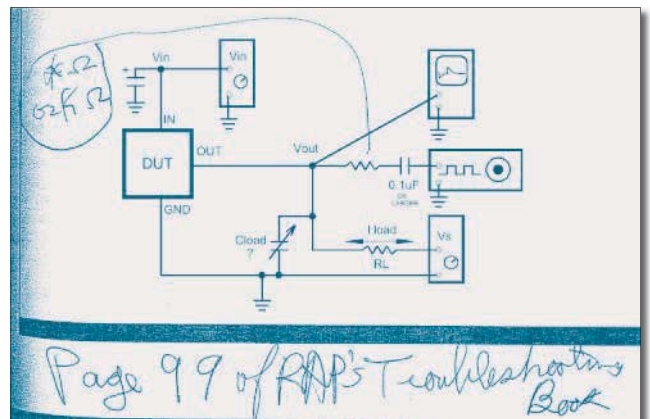

## WHAT'S ALL THIS CAPACITIVE LOADING STUFF, ANYHOW?



In 2008, Bob Pease exchanged e-mails with Paul Rako and other friends about how an amplifier will oscillate if you put a capacitive load on it.

## JOHN KISPERT DISCUSSES QSPI FLASH AND RECENT ACQUISITIONS



Spansion CEO John Kispert tackles the company's FL-iK quad-SPI serial flash memory and its purchase of Fujitsu's microcontroller and analog business.

join us online  

# “Superinductors”



## That's what engineers are calling our new ultra-low DCR power inductors

Superconductors pass current with virtually no resistance.

Our new XAL/XFL inductors do much the same. Their DCR is incredibly low: often half that of similar size parts.

And their current handling is equally impressive. Coilcraft's proprietary core material has a soft saturation characteristic that



*Competitors' 4.7uH inductors have much higher DCR per mm<sup>3</sup> than Coilcraft's XAL5030.*

prevents drastic inductance drops during current spikes.

Unlike competitive parts, these inductors don't suffer from thermal aging. And we give you far more footprint options to maximize PCB density.

To see what else makes our new XAL/XFL inductors so super, visit [coilcraft.com/xal](http://coilcraft.com/xal).

**Coilcraft**

WWW.COILCRAFT.COM

 [coilcraftdirect.com](http://coilcraftdirect.com)  
No min order. Next day delivery.

# Solving Your Board to Board Connector Design Challenges

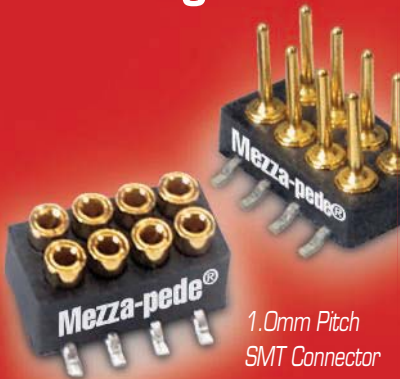

1.0mm Pitch  
SMT Connector

- Screw-machined Terminals
- Thru-hole or SMT
- Low Profile
- High Density
- Customized Designs
- Proven Performance



800.424.9850  
401.823.5200  
[www.advanced.com](http://www.advanced.com)  
info@advanced.com  
Made in USA

## EDITORIAL

CONTENT DIRECTOR: **NANCY K. FRIEDRICH** nancy.friedrich@penton.com  
CONTENT PRODUCTION DIRECTOR: **MICHAEL BROWNE** michael.browne@penton.com  
PRODUCTION EDITOR: **RICHARD GAWEL** richard.gawel@penton.com  
PRODUCTION EDITOR: **JEREMY COHEN** jeremy.cohen@penton.com  
ANALOG/POWER: **DON TUITE** don.tuite@penton.com  
COMMUNICATIONS: **LOUIS E. FRENZEL** lou.frenzel@penton.com  
DISTRIBUTION: **VICTORIA FRAZA KICKHAM** SourceESBEditor@penton.com  
EMBEDDED/SYSTEMS/SOFTWARE: **WILLIAM WONG** bill.wong@penton.com  
ASSOCIATE PRODUCTION EDITOR: **DENISE GRECO** denise.greco@penton.com  
ASSOCIATE CONTENT PRODUCER: **ILIZA SOKOL** iliza.sokol@penton.com  
ASSOCIATE CONTENT PRODUCER: **RICHARD DRYDEN** richard.dryden@penton.com  
EUROPEAN EDITOR: **PAUL WHYTOCK** p.whytock@btinternet.com  
ASSOCIATE EDITOR: **SALLY WARD-FOXTON** sally.ward-foxton@penton.com  
EDITORIAL INTERN: **SARAH MANGIOLA** sarah.mangiola@penton.com

## ART DEPARTMENT

GROUP DESIGN DIRECTOR: **ANTHONY VITOLO** tony.vitolo@penton.com  
CREATIVE DIRECTOR: **DIMITRIOS BASTAS** dimitrios.bastas@penton.com  
SENIOR ARTIST: **JAMES MILLER** james.miller@penton.com  
INTERN: **MIKE TAPIA**

## PRODUCTION

GROUP PRODUCTION MANAGER: **JUSTIN MARCINIAK** justin.marciniak@penton.com  
PRODUCTION MANAGER: **JULIE GILPIN** julie.gilpin@penton.com

## AUDIENCE MARKETING

AUDIENCE DEVELOPMENT DIRECTOR: **BRENDA ROODE** brenda.roode@penton.com  
ONLINE MARKETING SPECIALIST: **DAN KRAFT** dan.kraft@penton.com  
FREE SUBSCRIPTION/STATUS OF SUBSCRIPTION/ADDRESS CHANGE/MISSING BACK ISSUES | T | 866.505.7173  
electronicdesign@halldata.com

## SALES & MARKETING

BRAND DIRECTOR, e|DESIGN: **TRACY SMITH** T | 913.967.1324 F | 913.514.6881 tracy.smith@penton.com

## REGIONAL SALES REPRESENTATIVES

BRAND CHAMPION: NORTHEAST/EASTERN CANADA: **DAVE MADONIA** T | 212.204.4331 F | 913.514.3966  
dave.madonia@penton.com

SOUTH: **BILL YARBOROUGH** T | 713.636.3809 F | 713.380.5318 bill.yarborough@penton.com

NORTHWEST/NORTHERN CALIFORNIA/WESTERN CANADA: **JAMIE ALLEN** T | 415.608.1959 F | 913.514.3667  
jamie.allen@penton.com

MIDWEST/MID-ATLANTIC: **STEPHANIE CAMPANA** T | 312.840.8437 F | 913.514.3645 stephanie.campana@penton.com

PLEASE SEND INSERTION ORDERS TO: orders@penton.com

PENTON REPRINTS: **WRIGHT'S MEDIA** T | 877.652.5295 penton@wrightsmedia.com

CIRCULATION: **CUSTOMER SERVICE** T | 866.505.7173 F | 847.763.9673 electronicdesign@halldata.com

## INTERNATIONAL SALES

EUROPE: **MARK DURHAM** T | +44 (0)7958 564137 mark.durham@penton.com

ASIA: **HELEN LAI** T | 886 2 2727 7799 helen@two-way.com

JAPAN: **HIROKAZU MORITA** T | +81 3 3261 4591 F | +81 3 3261 6126

TAIWAN: **CHARLES LIU** T | 886 2 2727 7799 F | 886 2 2728-3686

KOREA: **JO YOUNG SANG** T | (011)82 2 739 7840

## LIST RENTALS: MERIT DIRECT

FREE SUBSCRIPTION/STATUS OF SUBSCRIPTION/ADDRESS CHANGE/MISSING BACK ISSUES | T | 866.505.7173 F | 847.763.9673  
electronicdesign@halldata.com

## ONLINE

ONLINE DEVELOPMENT DIRECTOR: **VIRGINIA GOULDING** virginia.goulding@penton.com

COMMUNITY LEADER: **RYAN MALEC** ryan.malec@penton.com

## DESIGN ENGINEERING & SOURCING GROUP

VICE PRESIDENT & MARKET LEADER: **BILL BAUMANN**

EXECUTIVE DIRECTOR OF CONTENT AND USER ENGAGEMENT: **NANCY FRIEDRICH**

GROUP DIRECTOR OF OPERATIONS: **CHRISTINA CAVANO**

GROUP DIRECTOR OF MARKETING: **JANE COOPER**

RESEARCH MANAGER: **JULIE RITCHIE**

MARKETING & EVENTS SPECIALIST: **ADRIAN PIAZZA**

## PENTON MEDIA INC.

CHIEF EXECUTIVE OFFICER: **DAVID KIESELSTEIN** david.kieselstein@penton.com

CHIEF FINANCIAL OFFICER: **NICOLA ALLAIS** nicola.allais@penton.com

SENIOR VP, DESIGN ENGINEERING GROUP: **BOB MACARTHUR** bob.macarthur@penton.com

1166 AVENUE OF THE AMERICAS, 10TH FLOOR

NEW YORK, NY 10036 T | 212.204.4200



Electronic Design | Machine Design | Microwaves & RF | Medical Design | Source ESB |  
Hydraulics & Pneumatics | Global Purchasing | Distribution Resource | Power Electronics |  
Mobile Dev & Design | Defense Electronics | Electronic Design Europe | Engineering TV

# Generate the exact waveforms you want. Introducing Agilent Trueform technology.

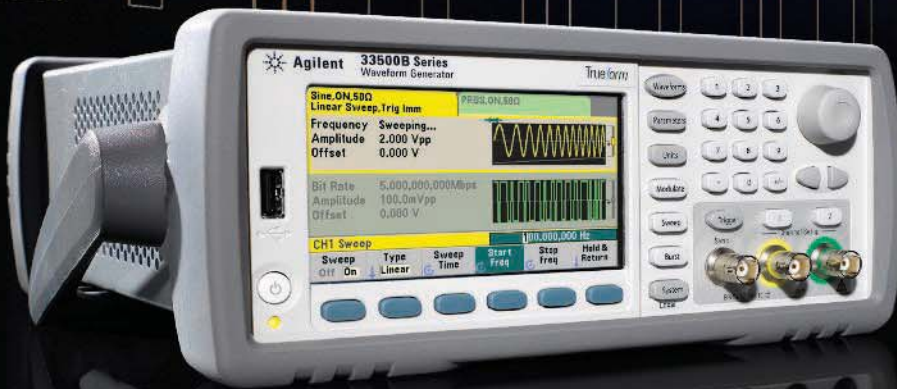

Agilent 33500B Series waveform generators with exclusive Trueform signal generation technology offer more capability, fidelity and choice than traditional DDS generators. Get the precision and flexibility you need to characterize new components and designs with superior confidence. And accelerate development from start to finish.

## 33500B Series Waveform Generators

- Sine waves with 5x lower harmonic distortion
- Pulses up to 30 MHz with 10x less jitter
- Point-by-point arbitrary waveforms with sequencing
- 16-bit resolution with 1 mV<sub>pp</sub> to 10 V<sub>pp</sub> amplitude
- 8 upgradable models in 20 & 30 MHz



Scan or visit  
<http://qrs.ly/lu2yhdn>  
to view a 33500B  
Series product overview

Agilent and our  
**Distributor Network**  
Right Instrument.  
Right Expertise.  
Delivered Right Now.

**TESTEQUITY**

800-732-3457  
[www.testequity.com/agilent](http://www.testequity.com/agilent)

Learn more about the advantages  
of Trueform waveform generation  
[www.testequity.com/Agilent\\_Function](http://www.testequity.com/Agilent_Function)

© Agilent Technologies, Inc. 2013

Anticipate — Accelerate — Achieve



Agilent Technologies

# Infinite Designs, One Platform

with the only complete  
system design environment



NI LabVIEW is the only comprehensive development environment with the unprecedented hardware integration and wide-ranging compatibility you need to meet any measurement and control application challenge. And LabVIEW is at the heart of the graphical system design approach, which uses an open platform of productive software and reconfigurable hardware to accelerate the development of your system.

LabVIEW system design software offers unrivaled hardware integration and helps you program the way you think—graphically.



**>> Accelerate your system design productivity at [ni.com/labview-platform](http://ni.com/labview-platform)**

800 453 6202

©2013 National Instruments. All rights reserved. LabVIEW, National Instruments, NI, and ni.com are trademarks of National Instruments. Other product and company names listed are trademarks or trade names of their respective companies. 12120





## MOOCs: The Gifts That Keep On Giving

If you aren't involved in some form of regular continuing education, you're doomed to suffer the consequences of ignorance, peer contempt, technological obsolescence, and eventual obscurity. And then you retire. I'm not kidding. Electronics never lets up. Changes occur hourly not only in the technology but also in the marketplace. You always need to know what is going on and how to turn the latest components, methods, trends, and technologies to your benefit. Continuing education is the answer.

We all are natural self-learners. You probably learn something new every day without realizing it. But you really need to formally assess your current needs and then develop some kind of learning activity to educate yourself. What topic would be the most beneficial to you today? Think about it. Have you learned DSP yet? How about ARM processors, Linux, or electromagnetic interference (EMI) mitigation? You also could pick up a foreign language, financial planning, project management, or how to use machine-to-machine communications (M2M) or wireless white spaces. Pinpoint a topic and then figure out a way to learn it.

For years, I've been asking engineers how they learn new stuff. Almost all say they use the Internet for most learning projects. Web searches usually turn up tons of material that you can organize into an informal self-instructional course. Webinars are a key source today, and many company-sponsored webinars are available for free. But to dig further, you may need to find the latest textbooks, university short courses, or company classes to get the level of learning you need.

### HIT THE BOOKS ONLINE

Massive open online courses (MOOCs) are now available too. Mainstream universities and some companies offer these Internet-based classes. There are non-credit online college-level MOOCs on every imaginable topic. Many are free, while others have a modest cost. MOOCs are still new, but the number of engineering-related courses has been expanding. There may be something there for you.

If you haven't yet discovered this learning alternative, take a look at what's available. Go to [www.mooc-list.com/categories/engineering](http://www.mooc-list.com/categories/engineering) for a quick review of what might interest you. Current and upcoming classes include Modeling and Simulation Using MATLAB, Concepts in Nanotechnology, Mobile Robotics, Digital Signal Processing, Introduction to Power Electronics, Linear Circuits, Mobiles for Development, and many more. Give yourself a MOOC for the holidays and get back to some kind of formal learning. 

#### JOIN US ONLINE

Become a fan @ facebook.com/ElectronicDesign





# Redefining Inductive Sensing

The technology of inductive sensing has been around for decades. It's utilized extensively in industrial automation as a means for counting gear teeth or accurately measuring distance to a metal surface without contact.

Historically, this technique has required complex circuitry, making it costly for applications outside of industrial controls or portable metal detectors. With new integrated solutions now available, though, inductive techniques can be applied to a far wider range of applications.

## INTRODUCTION

Walter Pepperl and Ludwig Fuchs first employed inductive sensing in 1958 in Mannheim, Germany. They wanted to find a technology to replace mechanical contacts that would wear out in hostile environments or were simply dangerous in explosive atmospheres due to arcing.

The basic principle of inductive sensing remains the same as Pepper & Fuchs' original design. It is based on an inductor-capacitor (LC) tank circuit pumped by an oscillator where the inductor is made from a sensing coil. As a conductive metal object is brought near the coil, eddy currents form in the object as a function of the distance, the material, and the size of the object.

The eddy currents form an opposing magnetic field that has the effect of reducing the oscillation amplitude. This has the apparent effect of changing the equivalent parallel resonance impedance ( $R_p$ ) of the tank circuit:

$$R_p = L/R_S C$$

$L$  is the coil inductance in henrys,  $R_S$  is the coil series resistance in ohms, and  $C$  is the parallel capacitance in farads. This change in the apparent parallel resistance is measured in these systems to determine distance to the target. It can be measured in several ways.

One method is to place a demodulator following the tank and digitizing the resultant dc value. As  $R_p$  changes, the amplitude of the tank diminishes. However, this scheme limits the system's dynamic range and is only useful for switching applications (metal object detected or not).

A superior method is to follow the demodulator with a closed-loop control system to maintain the LC tank's oscillation

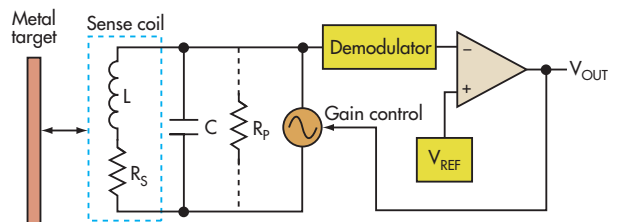

1. Closed-loop proximity detection can be used to accurately measure distance or size.

amplitude. As a metal object moves closer to the sense coil, the opposing magnetic field requires more drive current into the tank, which can be accurately measured. This technique provides a wider dynamic range in measuring  $R_p$  and improves the overall performance (Fig. 1).

## APPLICATIONS

There are many applications for inductive sensing. For example, mechanical buttons can be replaced in machine controls by simply placing a conductive metal slug at the top of each button so the distance between the top of the button and the coil decreases when it is pressed. Since the circuitry knows the position of the button, it could even detect how hard (via change in position versus time) the button was pushed. This could be useful for equipment stop switches where an operator may simply want to stop (in the normal shutdown time) a machine or execute a panic stop (which locks the machine immediately). This arrangement could detect both states.

Additionally, in harsh environments where dirt or corrosion would degrade a normal mechanical contact, this inductive proximity button would not be affected. It also can be used for intrusion detection in equipment racks or chassis. By placing the sensor near the door or access panel, the system could measure if it has been opened for security detection or shut down high-power equipment that potentially could be dangerous, all without the wear and corrosion problems of mechanical contacts.

There are far more applications beyond proximity detection for inductive-sensing technology. It can be used to measure rotation for applications such as anti-lock brakes, knobs, or flow-sensing turbines. This can be done by using a round tapered conductive metal target. As it turns over the sense coil,





# TAILORED.

**AVNET** SOLUTIONS MEET YOUR UNIQUE NEEDS

From big to small - we do it all.

Even big products begin small, with millions of sizes in between. We see them all. Here at Avnet, no order is too small. Avnet provides products and services to match your needs. No matter the location; whether you are in the new product introduction phase or extending a product's life. If you need design support, or supply chain assistance - we're here to help. With Avnet, you determine the scale of interaction - or complexity - and we will support you every step of the way, so it's a perfect fit!

What can we do for you? [www.avnetexpress.com](http://www.avnetexpress.com)

**Accelerating Your Success!™**

1 800 332 8638 | [www.avnetexpress.com](http://www.avnetexpress.com) |   @avnetdesignwire



# PICO

## Surface Mount and Plug-In

### 400 / 800 Hz Transformers

#### Now...

## up to 150 Watts



- 0.4 Watts to 150 Watts Power Transformers
- 115V/26V-400/800 Hz Primary
- Secondary Voltages 2.5V to 300V
- Manufactured to MIL-PRF 27 Grade 5, Class S, (Class V, 155°C available)
- Surface Mount or Plug-In
- Smallest possible size

See Pico's full Catalog immediately  
[www.picoelectronics.com](http://www.picoelectronics.com)



## PICO

### Electronics, Inc

143 Sparks Ave., Pelham, NY 10803

Call Toll Free 800-431-1064

E Mail: [info@picoelectronics.com](mailto:info@picoelectronics.com)

FAX: 914-738-8225



Delivery - Stock to one week

INDUSTRIAL • COTS • MILITARY

## EnergyZarr

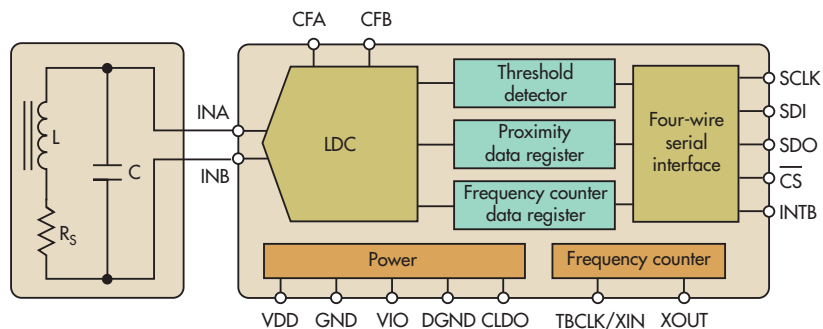

2. Texas Instruments' highly integrated inductance-to-digital converter includes closed-loop amplitude control for accurate measurements of distance or object size.

the amount of exposed area changes, allowing a measurement of the angle. By using a ramp-shaped metal target, linear position can be measured for applications such as closed-loop focus control in lenses or seat position in automobiles.

Another use of the same circuitry is to measure coil inductance. If the coil has a variable inductance such as a spring, it can become the sensor (without the use of a target conductive material). For instance, a spring can be used as a simple displacement sensor that already may be present in the system. An application example might be using the springs in a passenger car seat to measure the approximate weight of an occupant—required for determining if an airbag should be deployed in a collision.

This technique of using a spring as a sensor has many additional applications. If the circuitry is sensitive enough, slight changes in the deformation of the spring can be detected. This can be useful in applications such as elder care monitoring to measure respiration rate as a person sleeps. By instrumenting the bed springs, both respiration rate and occupancy can be monitored.

### HIGHER LEVELS OF INTEGRATION

To make these applications cost effective, higher levels of system integration are required. New and completely integrated inductance-to-digital converters have been introduced, such as the Texas Instruments LDC1000, that have extremely high accuracy and can be used for all of these applications and many more (Fig. 2).

By including the tank oscillator, closed-loop detector, counters, registers, and interface subsystems into a single package, engineers can now use inductive sensing in applications where it was previously too costly. Integration also enables additional applications that have not yet been conceived due to the lower cost and small size. (The TI solution is 4 by 5 mm.)

Applications for highly integrated solutions include game controllers, flow meters, printers, and musical instruments, as well as numerous automotive uses for seat belt detection, throttle and brake position, door sensors, closed loop seat position controls, and many others.

### CONCLUSION

Inductive sensing technology has been around for more than 50 years and is found in industrial control and manufacturing applications. It can sense distance to a conductive metal target, rotational angle, and linear position as well as measure the compression of a spring.

With the introduction of highly integrated inductance-to-digital converters, many new applications will be possible due to lowered implementation cost and size. Inductive sensing then can move into consumer products and white goods, improving mechanical performance and supporting completely new applications. 

**RICHARD ZARR** is a technologist at Texas Instruments focused on high-speed signal and data path technology. He holds a BSEE from the University of South Florida and patents in LED lighting and cryptography.

# THINK

SMT ENCLOSURE COIN CELL CONTACTS<sup>®</sup>

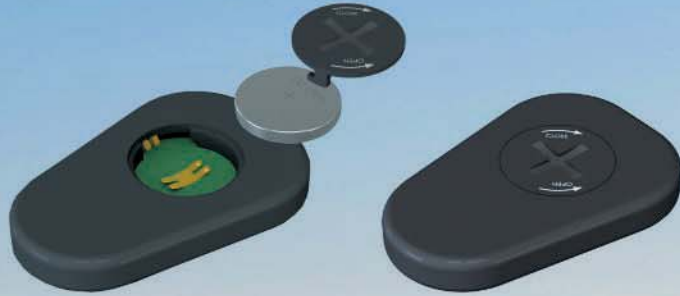
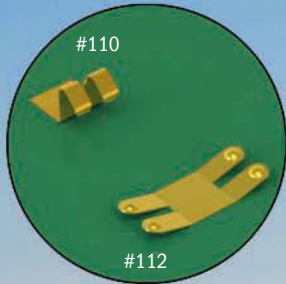

- Ideal for enclosures with self contained battery compartments
- Easy battery access, removal and installation
- Industrial and consumer product applications
- Ultra low profile
- Features gold-plated phosphor bronze contacts
- Spring tension contacts adjust to variations in battery diameter for a dependable connection
- Available on Tape & Reel
- Positive and Negative contacts can be used as a design set or individually on a PCB
- Accommodates cell diameters 16mm and larger
- Request Catalog M60.2

IT'S WHAT'S ON THE INSIDE THAT COUNTS

**KEYSTONE**<sup>®</sup>  
ELECTRONICS CORP.

www.keyelco.com • (718) 956-8900 • (800) 221-5510





50,12 REF. (A01)  
45,72 REF. (A02)  
dim.A ±0,05 (A03)  
10 (A04) 15 (A05)  
0,25 (A06) TYP.  
1,5  
Ø 1,0 (B02)  
Ø 0,6 (B01)  
1,0 (B03)  
0,3 chamfer (B)  
2,5 (B15)  
0,10 C (B16)  
4,5 (B17)  
10 10 C (B18)

**LET'S  
CREATE  
SOMETHING  
BRILLIANT  
TOGETHER**



SEE DETAIL

EVERY CONNECTION COUNTS



We understand the demanding process engineers go through to create products that make a difference, because we're engineers too, and we have the same passion for excellence and quality. We are dedicated to providing engineers with the critical components that help solve their biggest challenges. At TE Connectivity, we recognize every connection counts. Together, we can build something brilliant.

[Connect with us at everyconnectioncounts.com](http://everyconnectioncounts.com)

© 2013 TE Connectivity Ltd. All Rights Reserved.  
TE Connectivity and TE Connectivity (logo) are trademarks.



# Converter Breaks Ground In Sensing Performance

**DON'T BE FOOLED** by the simple name. The Texas Instruments LDC1000 inductance-to-digital converter is the most sensitive and versatile position-sensing technology ever offered. It could

even be called the death knell for Hall effect sensing as it measures the de-tuning effects of nearby conductors on LC tank circuits (Fig. 1).

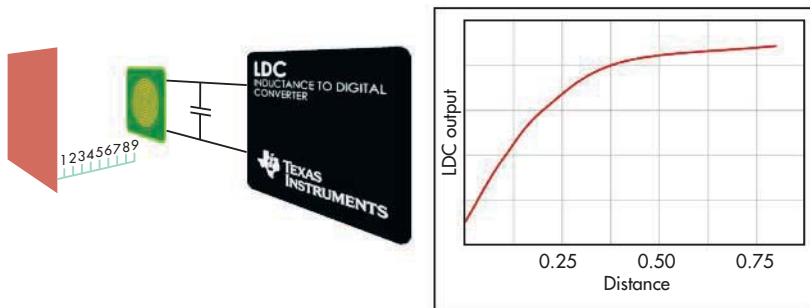

1. Although Texas Instruments calls the LDC1000 an inductance-to-digital converter, it is really a position sensor with 20-bit precision.

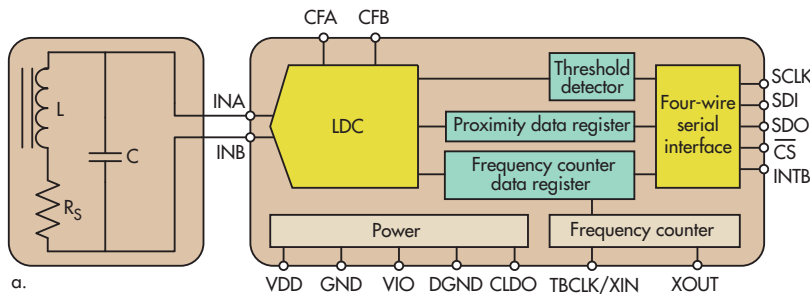

2. The LDC1000 drives an external LC tank circuit (left), which creates eddy currents in any conductive object nearby (a). The tank and the external object constitute a resonant transformer, and the effects of the eddy currents on the primary (the tank) are noted and used to determine changes in distance to the object (b).

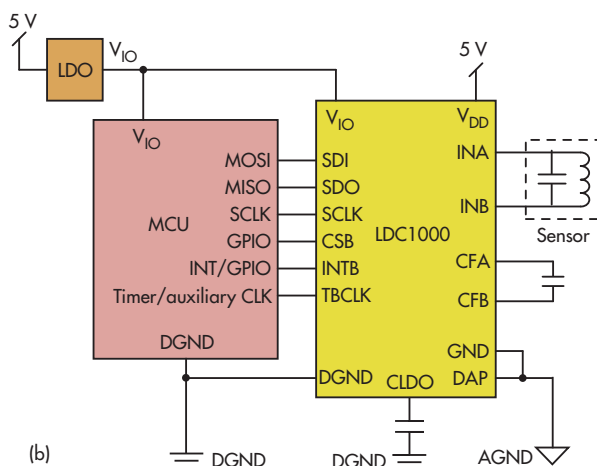

Typically, the coil in the tank is an external planar helix on a printed-circuit board (Fig. 2). Calibrated to read out changes in the coil's inductance to 24-bit precision, the LDC1000 drives and monitors the tank. The drive frequency, which determines the dimensions of the coil to some extent, can be anywhere from 5 kHz to 5 MHz.

## APPLICATIONS

The LDC1000's target applications all involve position sensing, particularly industrial, though medical and automotive also represent significant uses. Over the past decade, automobile makers have replaced virtually every mechanical position sensor with Hall effect sensors, which have become as cheap as mechanical limit switches and offer orders of magnitude greater reliability.

There's one problem with limit switches and Hall effect sensors, though. Their output is binary. They're open or closed. That's fine for sensing that the rear hatch is closed. They can even tell an engine control unit (ECU) that the shift lever is in drive, neutral, or reverse. But they can't resolve throttle or brake-pedal displacement. The LDC1000 can.

In addition, the LDC1000 technology isn't limited to precise measurements of linear displacement. Remember that planar inductor? Imagine what happens when a coaxially mounted metal disc gradually occludes it. The LDC1000 yields the same 24-bit precision for angular displacement as it does for linear displacement.

If that precision is repeatable, then, is it even usable? Texas Instruments says that an apparatus using the LDC1000 placed under a hospital bed can detect a patient's breathing rate. Texas Instruments aims to increase its sensitivity and false detection software to enable it to monitor heart rate from under a mattress as well.

### WHY IT WORKS

Based on practical experience, most engineers will accept that bringing their hand near a tuned circuit will de-tune it. It may be a little harder to accept the idea that the effect is consistently repeatable, much less repeatable to 24-bit precision.

An ac current in a coil will generate a field that causes eddy currents in nearby conductors. The eddy currents depend on the distance, size, and composition of the target conductor. In turn, the eddy currents then generate their own field, which opposes the field around the coil.

Consider the exciting coil the primary of a transformer and the external conductor a secondary, with some arbitrary L and R losses. Like all transformers, this one is passive and bilateral. It's also a parallel LC tuned circuit. That's where the original ac signal that's exciting the eddy currents in the "secondary" piece of metal is coming from. (Fans of Nicola Tesla should be starting to smile.)

Then, the LDC1000 measures the equivalent parallel resonance impedance,  $R_p$ , where:

$$R_p(d) = (1/([R_S + R(d)]) \times ([L_S + L(d)]/C)$$

The d designation indicates that those variables are functions of the distance to the disturbing conductor (Fig. 3).

The LDC1000 works by simultaneously measuring the impedance and resonant frequency of the external LC resonator that it's driving. It does this to regulate the oscillation amplitude to a constant level while monitoring the energy dissipated by the resonator. By monitoring the amount of power injected

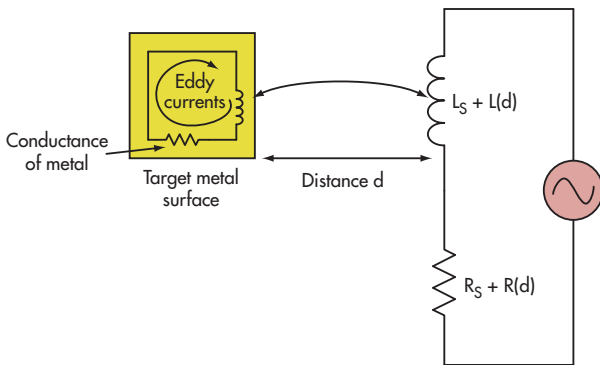

3. In an application, the LDC signals interface with an external micro-controller or FPGA.

into the resonator, it calculates the value of  $R_p$ . Also, measuring the oscillation frequency of the LC tank circuit determines the inductance of the helical coil in the LC circuit.  $R_p$  and frequency are output as digital values.

In addition to providing for oscillation frequencies from 5 kHz to 5 MHz, the value of  $R_p$  can theoretically range from 798  $\Omega$  to 3.93 M $\Omega$ . In practice, though, a circuit designer would select from a tighter range and enter those values in a pair of registers.

### DEMO BOARD

Naturally, there is a demonstration kit (Fig. 4). Its fiber reinforced plastic (FRP) demo board is a USB stick that could plug right into a desktop computer. Below that, and firmly mounted to a robust pivot assembly, is a metal plate that can be moved toward or away from the tank coil by a pivot assembly that can be displaced forward and backward by the digital-readout caliper. 



4. TI offers a reference design that comprises software and a USB-controlled circuit board with a helical coil for the LC tank. In this TI demo setup, an electronic dial micrometer changes the position of a metal object relative to the tank coil in fine increments so precision and repeatability can be compared.



# ET Boosts RF Power Amp Linearity And Efficiency

**PROBABLY NO OTHER** recent technology has done as much to improve the efficiency and linearity of RF power amplifiers (PAs) as envelope tracking (ET). And no other company has done as much to develop and make the technology practical and affordable as Nujira Ltd. While ET is not new, it is a tricky technology that Nujira has deployed to help make 4G LTE smart phones more efficient, providing greater battery life.

## ET CONCEPTS

Older 2G cell phones used modulation technologies that could be amplified by non-linear amplifiers that are far more efficient. Today with 3G and 4G technologies, linear amplifiers must be used to preserve the modulation content, which provides the speed required by demanding applications like video.

While linear PAs are readily available to do the job, their efficiency is poor. Class A or AB linear PAs rarely deliver efficiencies better than 25%, so considerable dc power is lost as heat. In addition, the overall higher power required shortens battery life, resulting in more frequent recharging.

Part of the problem lies in how linear PAs deliver their best efficiencies when they are operating in saturation. Known as compression, this occurs when the amplifier output begins to flatten when further input signal is applied. The optimum operating point is 1 dB less than the point where compression occurs.

The second part of the problem is that 3G and 4G signals like LTE have a high peak to average power ratio (PAPR), suggesting that the dynamic range of signals to be amplified is very wide. Orthogonal frequency-division multiplexing (OFDM) modulation used in LTE is particularly susceptible to high crest factors, producing multiple peaks and valleys of power. As a result, the amplifier spends a lot of time amplifying small signals where the power efficiency is low. With OFDM, as much as 80% of the PA dc power is wasted.

ET solves this problem. It varies the PA dc supply voltage to match the modulating signal level (Fig. 1). At peak signal levels, the dc collector or drain supply is high while the supply voltage is decreased at low signal levels. The result is that the PA is always operating near its optimum point for best efficiency.

An ET power supply modulator varies the supply. Nujira developed and perfected this technology. It improves efficiency and battery life while the amplifier remains linear, minimizing harmonics and intermodulation distortion (IMD).

While maintaining the amplifier in compression, digital pre-distortion (DPD) can further improve linearity. DPD takes a digital version of the signal and modifies it by an algorithm that compensates for any non-linearity. For example, an inverse function of the gain variation can correct any non-linearity in the PA gain caused by varying the supply voltage. This can be done in a lookup table.

A more comprehensive DPD technique samples the PA output with a fast analog-to-digital converter (ADC) and feeds the

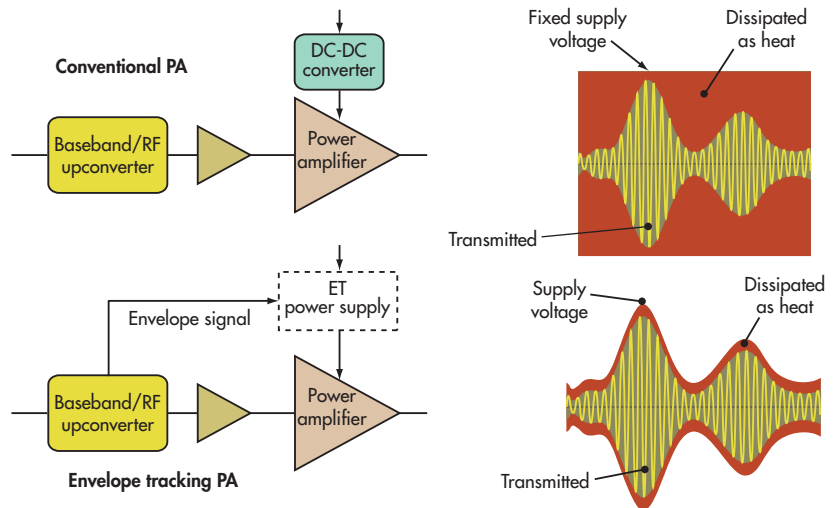

1. In conventional PA circuitry, the signal to be transmitted is sent to the PA usually via a driver amplifier. The PA supply voltage is fixed and delivered by a buck-type dc-dc converter. At low signal levels the wasted power (red area) is significant. With ET, the signal is sent to the PA for amplification in addition to the baseband envelope signal that is sent to the ET power supply modulator that varies the supply voltage. This approach keeps the amplifier in compression, improving efficiency and reducing dissipated heat.



signal back to DPD circuitry that forms the correct inverse function to linearize the PA. DPD with ET provides the optimum level of linearity and power/heat reduction possible.

### SIGNATURE PRODUCT

Nujira's Coolteq, L NCT-L1300 ET power supply (ETPS) is an alternative to common buck dc-dc converters used to power existing handset power amplifiers (Fig. 2). The IC tracks the base-band derived RF signal envelope and dynamically modulates the PA supply rail with wide bandwidth and tracking accuracy. The device maintains the PA in its highly efficient compressed state while providing constant gain despite any mismatched load.

Its benefit is best in high peak-to-average-power ratio (PAPR) modulation schemes like WCDMA, HSPA, and OFDM.

The NCT-L1300 boasts an input voltage range of 2.5 to 5.25 V and an output voltage range of 0.5 to 5 V in a buck-boost circuit format. The rms output power in ET mode is 1.2 W. Efficiency is 80%. The device supports an average power tracking (APT) mode to maintain high system efficiencies at reduced RF transmit powers.

The control interface is the MIPI RFFE 1.1 standard two-wire serial interface. The operating mode of the IC, either ET or APT, is controlled with a single write-mode signal. The modulation input is analog differential compliant to the OpenET Class 2.0 specification. The device works with IC PAs with power levels up to 29 dBm and can potentially increase overall efficiency to the 40% to 50% range.

The basic bandwidth specification of the NCT-L1300 is less than 20 MHz, which is very usable even in LTE applications. However, this same part can achieve a bandwidth of 40 MHz. Nujira tested the device by transmitting a 200 resource block LTE waveform using the carrier aggregation feature of LTE-Advanced to achieve an instantaneous data rate of up to 150 Mb/s. The test PA delivered 27-dBm output with an error vector magnitude (EVM) of 3% and an adjacent channel leakage ratio of -35 dBc.

The latest versions of the NCT-L1300 break the 50% efficiency level in LTE applications. It can achieve an adjacent channel performance of better than -50 dBc without DPD. The typical noise specification is -135 dBm/Hz. The fast mode switching lets the device support both TD-LTE and FD-LTE formats.

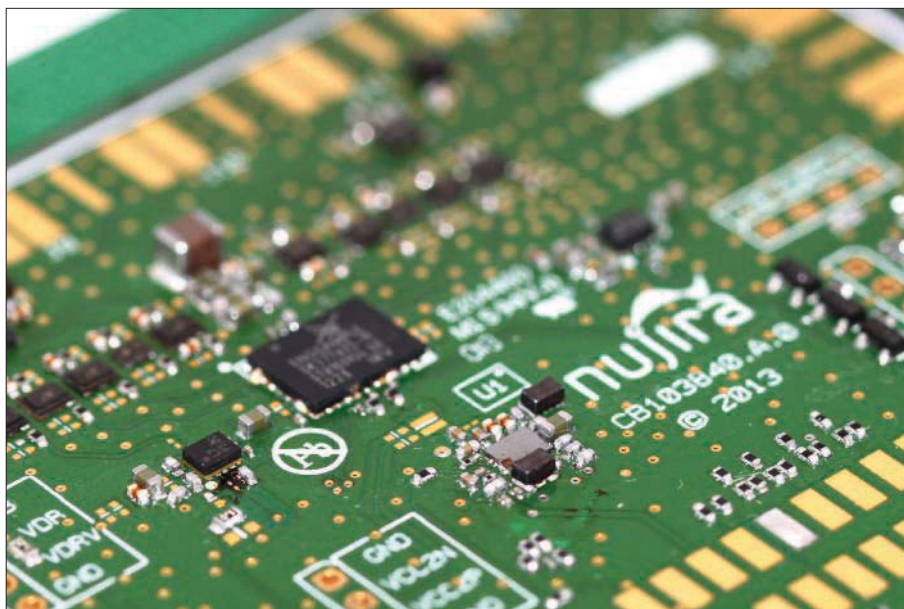

2. The Nujira NCT-L1300 is the gray chip in the center of the board. This is all you need to linearize one or more PAs in LTE handsets for maximum efficiencies in the 45% to 50% range.

Additionally, ET can make CMOS PAs suitable for LTE. Most handset PAs are gallium arsenide (GaAs). They work well and most handsets use them, though they are expensive. CMOS PAs are available but have not proven to be linear enough for LTE. They are used in some 2G and 3G phones because of their low cost. Now combining an inexpensive CMOS PA with a Nujira ET chip creates an LTE-suitable PA. Recent Nujira tests indicate an adjacent channel leakage power ratio of -38 dBc with a 28-dBm CMOS amplifier achieving 57% efficiency.

A 16-band, multi-mode, multi-band ET reference design targets RF front ends for 4G smart phones. It uses the NCT-L1300 ET chip along with a minimum number of PAs to cover the wide range of LTE frequencies from 700 MHz to 2700 MHz. This makes it possible to greatly reduce the number of PAs but also provides a way to minimize the number of phone models to cover selected 3G and 4G bands.

Incidentally, while the signature part is the NCT-L1300, Nujira also makes an ET power modulator for LTE cellular basestations and remote radio heads. Designated the HCT-H4010, the module supports power levels to 60 W and provides an alternative to some of the Doherty PAs used in basestations to improve efficiency.

Finally, Global Cleantech 100 recently recognized Nujira for its energy savings products. This is the third year in a row that Nujira has received such recognition. Global Cleantech 100 is a list of companies with the most promising private environmentally friendly technology expected to have a significant impact on the market over the next five to 10 years. 



# Memory Channel Storage Puts SSD Next To CPU

**DIABLO TECHNOLOGIES'** Memory Channel Storage (MCS) made a big splash when it was first released as TeraDIMM, and for a good reason. This dual-inline memory module (DIMM) brings terabytes of flash memory to processor memory channels instead of having it connected via disk interfaces like Serial ATA (SATA), Serial Attached Storage (SAS), or even PCI Express (Fig. 1). It essentially puts the solid-state disk (SSD) next to the cores instead of one or two peripheral interfaces away from the applications.

Hard-disk storage interfaces like SATA provided sufficient bandwidth to handle devices that also had very high latency levels compared to DRAM. It made sense to utilize an interface that would hide the complexity of the storage device.

Solid-state storage changed the interface equation. Its lower latency and faster transfer rate still weren't on par with DRAM, but it was significantly faster than hard-disk storage. The interface started to be the bottleneck. Moving SSDs closer to the processor was the reason for connecting flash memory via PCI Express. PCI Express bandwidth is higher than storage



1. Diablo Technologies' Memory Channel Storage (MCS) plugs into a standard DIMM socket and implements the DDR3 protocol, but it has flash memory chips on board, not DRAM.

interfaces like SATA and SAS because it has to handle these interfaces as well.

### KEY FUNCTIONALITY

This is why companies like Fusion-io have been delivering PCI Express-based flash memory storage products. The non-volatile memory NVMe Express (NVMe) standard is one interface designed to bring flash memory storage to the processor that is built on PCI Express.

Still, even PCI Express can limit flash memory storage performance. It provides a low-overhead interface, but using the

DRAM memory interface can reduce that overhead further.

The challenge is that this interface was designed for volatile, byte-accessible memory that requires periodic refreshing.

DDR3 DIMMs also implement a demanding communication protocol for initialization and general operation. Unfortunately, simply replacing DDR3 DRAM memory chips with flash memory chips is not an option. Diablo Technologies had other ideas.

MCS plugs into the DDR3 DIMM sockets. Its Diablo Technologies controller chip implements the DDR3 protocol and interfaces with the on-module flash memory chips, which include support found in

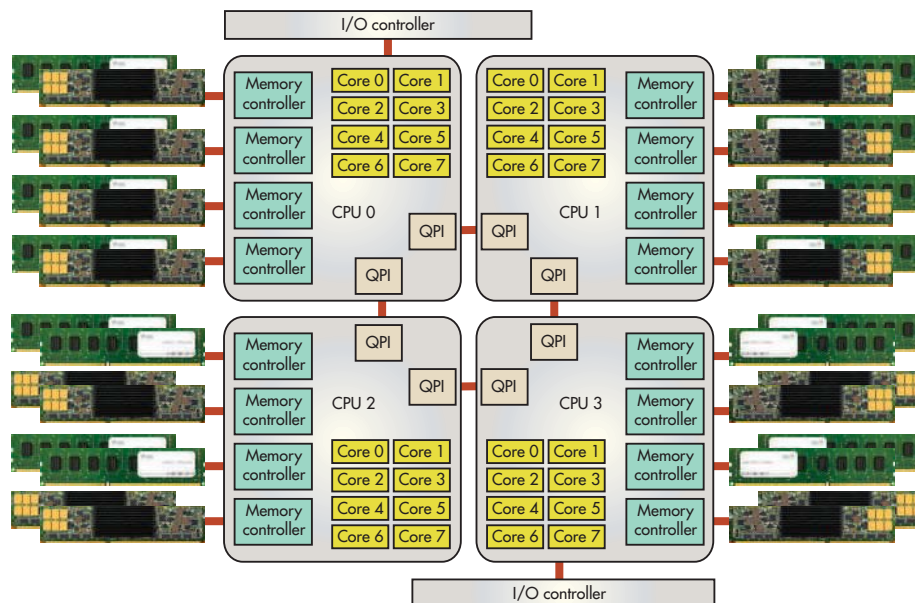

2. TeraDIMM can be mixed with DRAM DIMMs. Used on multiple channels, it increases bandwidth available for flash storage access.

advanced flash memory controllers such as wear leveling.

Diablo Technologies' first partner was SMART Modular Technologies. The SMART ULLtraDIMM employs Diablo Technologies technology along with SMART's Guardian Technology Platform architecture for flash memory storage.

The ULLtraDIMM has less than 5- $\mu$ s write latency and a random performance of 150k read IOPS and 65k write IOPS. The sustained read and write performance is 1 Gbyte/s and 760 Mbytes/s, respectively. This scales linearly while maintaining a consistent write latency. The DIMMs are available in 200-Gbyte and 400-Gbyte versions. They use 19-nm multi-level cell (MLC) flash memory chips. And, the ULLtraDIMM can handle up to 10 full rewrites for five years.

MCS targets enterprise class servers with multiple memory sockets and multiple channels per processor (Fig. 2). The memory channels provide the highest bandwidth interface to the processor. This accelerates memory access and enables the connection of terabytes of flash storage directly to the processor.

#### KNOW YOUR TRADEOFFS

The tradeoff between DRAM and flash storage in large installations is critical, though. Many applications need as much DRAM as possible and fill all DRAM sockets. Users need to determine the proper mix of DRAM and MCS storage. Some applications may benefit from more flash storage.

The other advantage of using the DIMM approach in a multi-processor, multicore system is that the memory channels are logically shared among all cores. This non-uniform memory architecture (NUMA) approach has different latencies for accessing storage not directly attached to the processor chip, but it is very low. It does allow any core to access any MCS DIMM, though. Most enterprise systems will take a balanced approach, but an embedded system that could partition the software might dedi-

cate a processor chip or two for non-volatile storage chores and attach some or all of the flash memory DIMMs directly to those chips.

DRAM DIMMs must be added in a balanced fashion when using multiple memory channels. The same type of DRAM needs to be used on each channel because DRAM is accessed in parallel. On the other hand, MCS storage can be added one DIMM at a time since each DIMM is designed to be accessed individually. Different capacity MCS DIMMs can be used on any memory channel, although most installations are likely to use the same style DIMM within a system.

MCS DIMMs require BIOS support so they can be recognized and properly initialized. Likewise, operating system (OS) support is necessary to handle this type of flash storage. Device drivers are the easiest way to make this work. The MCS memory then can be utilized like an SSD. The only difference is the available bandwidth and reduced latency.

The other alternative is to provide direct access by the OS and applications. This requires OS modifications that Diablo Technologies is developing. It eliminates even the device driver overhead.

In some sense, programmers are relearning technology that used to be quite common when core memory was the standard. There is a difference because core memory is more akin to non-volatile DRAM. Viking Technology's ArxCis-NV NVDIMM uses this type of approach. This DIMM backs up and restores DRAM to on-module flash. An off-module supercap provides transition power when system power is removed either accidentally or on purpose.

The ArxCis-NV NVDIMM runs at DRAM speeds and looks like DRAM to the processor cores. The difference between it and Diablo Technologies' MCS is capacity and speed. Mixing DRAM, NVDIMMs, and MCS DIMMs in a system would be possible and may be useful for some high-performance, high-reliability applications. 

# PICO

## DC-DC CONVERTERS

2V to 10,000 VDC Outputs  
1-300 Watt Modules

Regulated/Proportional/Programmable  
Isolated/Single/Dual Outputs

High Reliability  
Greater than 1,000,000 hrs.  
Mil Hbk 217F

Military Upgrades  
Expanded operating temperature  
-55° to +85° C, no derating required

Environmental Screening  
Selected Screening, Mil Std 883

ULTRA Miniature  
From 0.5" x 0.5" x 0.2"

Surface Mount/Thru-Hole

- Custom Models
- US Manufactured
- AS 9100 Approved

High Reliability AC/DC  
Power Supplies, Transformers  
and Inductors



See PICO's full line catalog at  
[www.picoelectronics.com](http://www.picoelectronics.com)

### YOUR PROVEN SOURCE.

Over 40 years providing  
reliable products.  
Over 2,500 Standard Modules.

800-431-1064



**PICO** ELECTRONICS, Inc.

143 Sparks Ave., Pelham, New York 10803  
Call Toll Free 800-431-1064 • FAX 914-738-8225  
E Mail: [info@picoelectronics.com](mailto:info@picoelectronics.com)



# 3D Video Sensors Improve User Interactivity

**MOBILE AND PC USER INTERFACES** have moved past the keyboard and mouse to touch and non-touch interfaces. Capacitive touch interfaces are the norm with smart phones and tablets. Non-touch interfaces are the new technology, and they will be found in more devices in 2014 (see *“Consumer Electronics Take User Interfaces Beyond Your Fingertips”* at [electronicdesign.com](http://electronicdesign.com)).

3D imaging is one of the non-touch interfaces that is having a major impact even as other 3D technologies such as 3D printers are also taking off. Hollywood, for example, is using dual cameras to make major motion pictures in 3D (see *“Prometheus Takes Flight With Cutting-Edge VFX Technology”* at [electronicdesign.com](http://electronicdesign.com)). The cameras are expensive, and so is the mechanical and electronic support hardware. Low-cost, dual-camera solutions are available, but they tend to be more expensive than the two other 3D imaging technologies.

## TOP TECHNOLOGIES

Microsoft’s original Kinect sensor for the Xbox gaming system uses one of these 3D imaging technologies from PrimeSense (see *“How Microsoft’s PrimeSense-based Kinect Really Works”* at [electronicdesign.com](http://electronicdesign.com)). The PrimeSense system emits an infrared pattern that is read using a 2D infrared sensor. A system-on-chip (SoC) analyzes the distortion of the pattern reflected back to the sensor to generate the 3D depth field.

The other available 3D imaging technology measures time-of-flight from an emitter to the sensor (see *“Time-Of-Flight 3D Coming To A Device Near You”* at [electronicdesign.com](http://electronicdesign.com)). This is what SoftKinetic’s DS311 3D sensor does (Fig. 1). Microsoft’s Kinect 2 for the Xbox One employs the time-of-flight approach (see *“Xbox One And PlayStation 4 Look More Alike”* at [electronicdesign.com](http://electronicdesign.com)).



1. SoftKinetic’s DS311 can handle hand and finger recognition at a range of 0.15 to 1 m. It can also manage body recognition from 1.5 to 4.5 m using a brighter IR emitter setting.

2. The SoftKinetic module allows developers to easily incorporate 3D sensing in embedded applications.



3. Creative Technology’s Sens3D employs SoftKinetic’s DepthSense technology.

Developers have access to SoftKinetic's DepthSense technology, which the DS311 uses. The module is available to OEMs, so embedded developers can incorporate non-touch 3D sensing in their applications (Fig. 2). This technology also is inside Creative Technology's Senz3D (Fig. 3). SoftKinetic has licensed its DepthSense pixel technology to Melixis and Texas Instruments (TI). The 3D Current Assisted Photonic Demodulator (CAPD) sensor is available from SoftKinetic's partners.

The DS311 combines a 2D color camera with the 3D sensing system to deliver a color image with 3D depth information. The image recognition software also can use the color information to identify and track objects from balls to arms. The DS311 incorporates dual microphones as well to support video conferencing and recording. Video and image recognition can operate at speeds up to 60 frames/s.

The main difference between the DS311 and the Senz3D is that the DS311 can handle hand and finger recognition at a range of 0.15 to 1 m in addition to body recognition at a range of 1.5 to 4.5 m. Designed for hand and finger gesture recognition, the Senz3D replaces a laptop HD camera. The DS311 uses a brighter infrared emitter that can be used for both, although only one mode at a time. SoftKinetic's technology and the Senz3D are the reference design for Intel's Perceptual Computing software development kit (SDK).

Body movement and gesture recognition software are part of the SDK. SoftKinetic provides this technology as well. The hand and finger gesture recognition address Senz3D deployments. Future laptops and tablets will have this hardware built in. Users will be able to swipe by gesturing instead of touching the screen. Body movement and gesture recognition is more for gaming platforms and applications like Microsoft's Xbox.

Mobile device application control and gaming are just two applications for 3D

time-of-flight sensors and software. 3D scanning for 3D printing is yet another. They are also useful for robotic applications that need to identify objects to locate and avoid, such as parts on an assembly line or people in a hallway. 

#### MORE FROM BILL WONG

For more of Bill's rants and raves about the latest hardware and software, check out his blog at <http://electronicedesign.com/blog/altembedded>.



## Powering your next design.

**Let us be your power expert.** We understand that you don't have the time to master every aspect of electronic design. As a leading manufacturer of power supplies we are here to collaborate with you to ensure your next project is a success.



Novum®  
Advanced Power



Ac-Dc  
Power Supplies



Dc-Dc  
Converters



[www.cui.com/PowerExpert](http://www.cui.com/PowerExpert)



# Power Controller & Interface Transform POL Regulation



**IN NOVEMBER, INTERSIL ANNOUNCED** a new family of power management ICs, including a highly integrated, digital dc-dc power controller with what it calls a “ChargeMode” control loop technology. ChargeMode eliminates control loop compensation from the design process. The ZL8800 enables fast transient response without compensation, reducing design time. And thanks to its excellent transient response, it reduces output capacitor size and board space, according to the company.

Target systems typically require control and monitoring of every power rail to maximize reliability. System designers use external monitors and sequencers to provide the added functionality around the point-of-load converters (PoLs). The ZL8800 integrates all of those functions and provides for control through the industry-standard PMBus interface. Telemetric data on the power supply includes temperature, input current, output current, input voltage, and output voltage.

ZL8800 output can operate independently, or it can be paralleled, with split phases, to supply higher current levels. Output voltages can range from 0.54 to 5.5 V. Input voltages can range from 4.5 to 14 V.

## POWER NAVIGATOR GUI

Intersil’s PowerNavigator user interface simplifies design with the ZL8800. Designers can use the drag-and-drop utility to set up and control any power supply architecture.

“Traditional digital power controllers achieve loop stability using the same pole-zero placement approach as analog control techniques, except in the digital domain they implement PID (proportional-integral-derivative). While well understood, this approach does not take advantage of the benefits offered with digital signal processing to enable stable, fast transient response power supplies,” said Chance Dunlap, senior marketing manager at Intersil.

“The proprietary ChargeMode control loop from Intersil is the first digital loop to break away from the traditional approach, utilizing digital control to its full extent. Implementing non-linear control with over-sampling of the output, a wide loop bandwidth can be obtained without excessive phase shift. In addition, a unique digital convergence approach ensures that the loop remains stable without the need for compensation,” Dunlap said.

“With Intersil’s fourth generation ChargeMode digital controller, a power supply can now be realized that offers high performance with fast design time and high reliability, while avoiding complicated compensation settings,” he said.<sup>1</sup>

## HISTORY

To understand why this is a landmark product, it helps to review the evolution of PoL voltage regulation. The part of Intersil that developed the new devices used to be Zilker Laboratories. So, this announcement primarily concerns PoL dc-dc conversion using the Intermediate Bus Architecture (IBA) under a somewhat loose definition of IBA. Intersil acquired Zilker Labs in the first quarter of 2009.

Turn back the clock to 2004, when IBA was a bright and shiny new thing. Powering the arrays of cabinets filled with blade servers in data centers was a challenge. Each of the CPUs in these blade servers had three or four power rails whose current demands would switch wildly between milliamps and amps as the CPU chips switched from dormant states to full activity.

IBA distributed unregulated 48-V dc from a front end at the ac power drop to the cabinets. Inside the cabinets, each board in the system has its own step-down supply, or bus converter, that

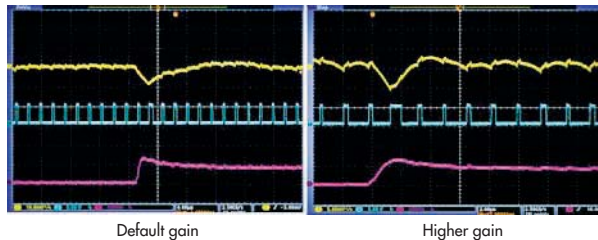
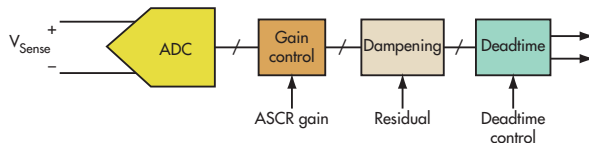

Intersil’s PowerNavigator software handles ChargeMode control transparently within the GUI. The value of ASCR “gain” optimizes transient response. It can range from 100 to 1200. Its default value is 256. “Residual” sets the dampening factor and affects overshoot. It can take any value from 0 to 100, but it’s usually set at 90.

changed the front end's 48 V to 12-, 8-, or 5-V bus voltages. Then the bus voltage was stepped down and regulated by PoL buck converters at each load. The key to making those PoLs work was abandoning the idea of analog feedback in the bus converters and going to digital control loops.

The issue of digital control created lots of controversy. During the 2004 IEEE APEC conference, there was spirited debate during the sessions of the Power Supply Manufacturers Association as to whether digital control would really work, whether anybody would pay for it, and whether design engineers at the systems-level companies would abandon their familiar analog design approaches.

This opened the door to a number of semiconductor startups that were committed to making the design of digitally controlled dc-dc converters, especially in data centers, simple and bulletproof. Early innovators included Primarion (now part of Infineon), Power-One (acquired by ABB), Silicon Laboratories, Vicor (with a proprietary alternative to IBA), and Zilker Labs (now with Intersil).

Each of these companies approached the market with design tools that included some kind of graphical user interface (GUI) intended to simplify, among other things, the task of compensating the voltage-control loop in the digital domain by programming PoLs without human intervention. Some of these GUIs were simple "fill in the box" screens. Others had on-screen sliders and dynamic displays of the feedback transfer function that let power supply designers develop a "feel" for potential circuit behavior.

Meanwhile, simple dc-dc PoL regulators grew more functionally complicated. With the "hard part" of the design streamlined by the GUIs and the software behind it, it became a point of product differentiation to enhance conversion efficiency across broad load-current ranges using techniques such as paralleling multiple digital PoLs while staggering their clock phases. There was also differentiation in external control buses.

Zilker Labs was one of the leaders in this aspect of power supply design, but it always did things a little differently. In 2006, it introduced a controller-less autonomous approach for multiple PoLs in which regulators in the group would turn on in order, starting with the device with the lowest address and continuing until all of the devices in the chain were on.

No device would start its turn-on routine until the previous device was in regulation. The device with the highest address would turn off first, followed in reverse order by the other devices in the group. The clock was automatic in phase-spreading, when all converters were synchronized to the same switching. The phase offset for each chip was determined by its device address. Phase offset was the device address times 45°.

In 2008, Zilker introduced PoLs that provided what the company calls

adaptive compensation. The new chips then could dynamically modify loop-compensation coefficients in response to varying load conditions, without external components.

Thus, the ZL8800 and Power Navigator continue the evolution of digital power control. In another sense, they're more than an incremental step forward, thanks to the totally compensation-capacitor-free loop control and the simplicity of the drag-and-drop user interface. **ed**

#### REFERENCE

"ZL8800—Understanding the ASCR Gain and Residual Compensation," [www.intersil.com/cn/tools/video-popup.html?vid=2763959548001](http://www.intersil.com/cn/tools/video-popup.html?vid=2763959548001)

#### MORE FROM DON

For more on analog and power technologies from Don, go to <http://electronicdesign.com/author/don-tuite>.

**\$51<sup>For 3</sup> PCBs**  
**FREE Layout Software!**  
**FREE Schematic Software!**

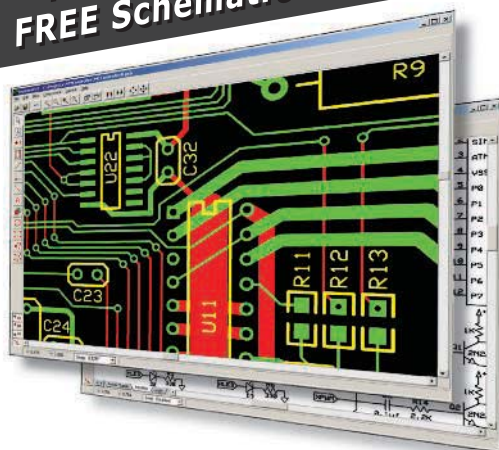

- 01 DOWNLOAD our free CAD software
- 02 DESIGN your two or four layer PC board
- 03 SEND us your design with just a click
- 04 RECEIVE top quality boards in just days

**expresspcb.com**



# HSA Hardware Framework Changes CPU/GPU Software

**AMD'S HETEROGENEOUS SYSTEM ARCHITECTURE (HSA)** hardware framework provides Heterogeneous Uniform Memory Access (hUMA) to CPUs and GPUs (Fig. 1). It radically changes the way CPUs and GPUs will interact at the software level.

In the past, GPUs were implemented as separate entities with their own memory and a communication channel to the host processor. The host would use the channel to move data and GPU code into the GPU memory. Initially, the GPU was used only for driving displays. The software was a closed system that only the GPU vendor could access.

Eventually the GPU vendors opened up the GPU for computational chores because the number of cores and the GPU architecture could sometimes improve speed by as much as two orders of magnitude. Not all applications show this much improvement, but many provide significant advantages over CPUs.

## IN OPERATION

GPUs have moved from their display-only chores into computation-only applications or mixed environments where the GPU handles display and computation chores at the same time, much like how a CPU handles multitasking.

Programming a GPU can get tricky because of its architecture, which synchs a number of cores in a more advanced single-instruction, multiple-data (SIMD) configuration. Higher-level programming frameworks like NVidia's CUDA (see "Is Your Personal Computer A CUDA-Enabled Speed Merchant?" at [electronicdesign.com](http://electronicdesign.com)) and OpenCL (see "OpenCL 2.0, OpenGL 4.4 Officially Released" at [electronicdesign.com](http://electronicdesign.com)) have made the job significantly easier by simplifying the movement of data between the CPU and GPU memory.

The movement of data from one memory to another has a range of impacts including

address translation issues. The copying and translation issues disappear when HSA is used because the CPU and GPU share the virtual address space.

HSA supports existing software development frameworks like OpenCL that are currently used on GPUs and CPUs. This makes migration to HSA platforms easier. There are several ways to do this, including simply using the CPU and GPU, as in the past. It doesn't take advantage of HSA, but it will work. Recompilation to take advantage of HSA could significantly improve performance.

Software development becomes more interesting when compilers and operating systems have native HSA support. Popular C/C++ compilers like gcc and LLVM will support HSA. Other compilers will also support HSA, including Java.

The OpenJDK Sumatra Project is designed to put Java on top of HSA, generating a combination of CPU and GPU code depending upon the application (Fig. 2). HSAIL is a virtual machine for the GPU. It has a byte code designed to mimic GPU functionality but at a generic level, just like the Java Virtual Machine (JVM) is used for CPUs. The HSAIL Finalizer generates native GPU code from the byte code generated by compilers like gcc or LLVM. This maintains Java's portability

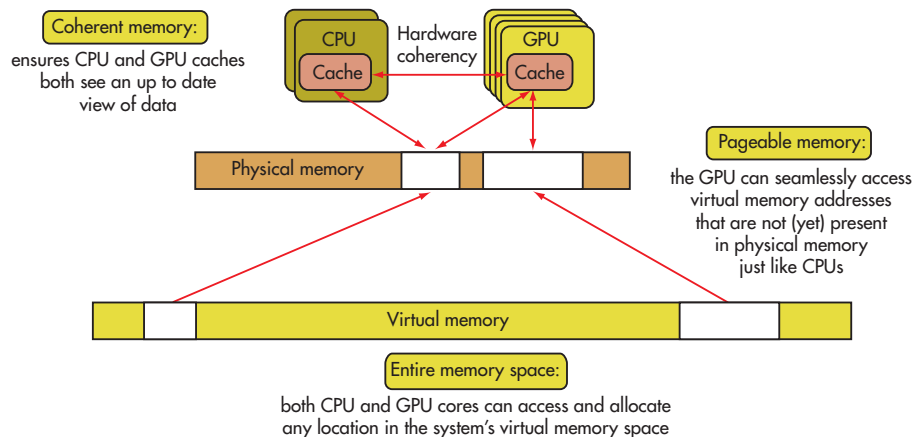

**1. AMD's Heterogeneous System Architecture (HSA) allows CPU and GPU cores to use the same virtual memory address space so data does not have to be copied for use by different types of cores. This greatly simplifies programming and considerably improves speed.**



while allowing a compatible Java application to run on a range of CPU/GPU combinations.

HSA also includes hQ, which allows CPU and GPU task management. It enables tasks running on each platform to invoke and interact with tasks running on the other platform. Also, the AMD CodeXL tool suite provides GPU debugging as well as CPU and GPU profiling. It is currently available as a Microsoft Visual Studio plug-in and as a standalone application running under Windows or Linux.

#### ON THE MARKET

AMD's Kaveri desktop APU will be the first platform to include HSA support. Kaveri chips will be available in 2014. The Bolt C++ Standard Template Library (STL) is optimized for the HSA heterogeneous computing platforms. Bolt C++ STL will let C++ programmers utilize an HSA APU without resorting to the more complex OpenCL approach.

HSA is not specific to a CPU or GPU architecture. Not all vendors that will be building CPU/GPU SoCs will adopt it, but some versions will be built around Arm CPUs and other GPU architectures. The HSA Foundation that was formed to manage the architecture includes major chip vendors such as AMD, Arm, Texas Instruments, Samsung, and Qualcomm. 

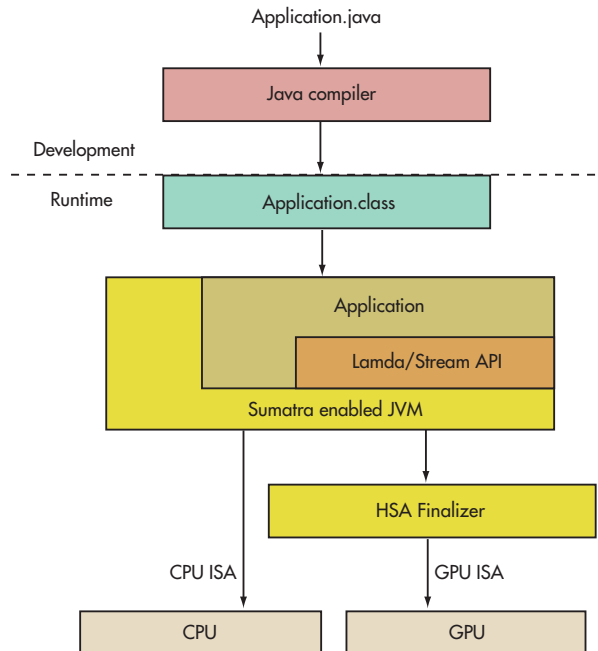

2. Java will eventually have seamless HSA support via the Sumatra project, which will generate code for CPU and GPU cores as necessary.

# INRUSH CURRENT LIMITERS



ISO 9001: 2008 Certified



Use a one component solution for inrush current in electric motors, drives, and power electronics.

- ▶ For power supplies with outputs from 50 to 7,500 watts and 1.0 to 50 AMPs SSI
- ▶ Limit up to 900 joules of inrush energy
- ▶ UL & CSA rated, RoHS compliant, and meet Reach regulations standards
- ▶ Free samples, fast shipping, and competitive pricing

**AMETHERM**  
Circuit Protection Thermistors

CONTACT US FOR  
**FREE SAMPLES**



ALSO AVAILABLE THROUGH



800-808-2434 • 775-884-2434 (outside the US and Canada) • [www.ametherm.com](http://www.ametherm.com)



# New Gear Accelerates 100/400-Gbit/s Optical Testing

**AS ELECTRONIC COMMUNICATIONS** circuits and systems become more complex and critical, testing grows far more difficult. Also, new standards impose unusually demanding specifications that take time to validate. One key outcome is a significant increase in production test time that is now a big part of the cost of any new product.

This certainly is the case with new 100/400-Gbit/s fiber-optical components and products. These super-high data rates present a challenge not only in research, design, and development but also in production. Tektronix's optical solutions, which mix new products, existing products, and product enhancements, simplify and speed up optical testing.

## 100-GBIT/S TESTING

The demand for ever-faster Internet access continues to increase along with mobile data speed and volumes thanks mostly to video applications. Ever-faster fiber-optical networks in long-haul, short-reach, and backhaul systems are addressing the need for extra speed. While 10-Gbit/s systems are common, more carriers and companies are upgrading to 40-Gbit/s and 100-Gbit/s systems. New components and products are now available to meet the demand.

Several different standards support the 100-Gbit/s rate. For short-haul applications such as data centers, disk arrays, private local-area networks (LANs), and metro networks, Ethernet 802.3 standards are usually used. For example, Ethernet 100GBASE-R4 uses four parallel multi-mode or single-mode fibers, each with a data rate of 25 Gbits/s (25.78 Gbits/s actual). Sonet OTU4 uses four parallel fibers to deliver 25 Gbits/s (27.95 Gbits/s actual).

Another common test need is shorter electrical connections in optical switches, routers, and transport or data center equipment. The Optical Internetworking Forum (OIF) has common electrical interface (CEI) standards called implementation agreements (IA) that define 4x25G links over backplanes or from chip to chip or chip to module. The most common are CEI-25G-LR (long reach) and CEI-25G-VSR (very short reach), which present their own test challenges.

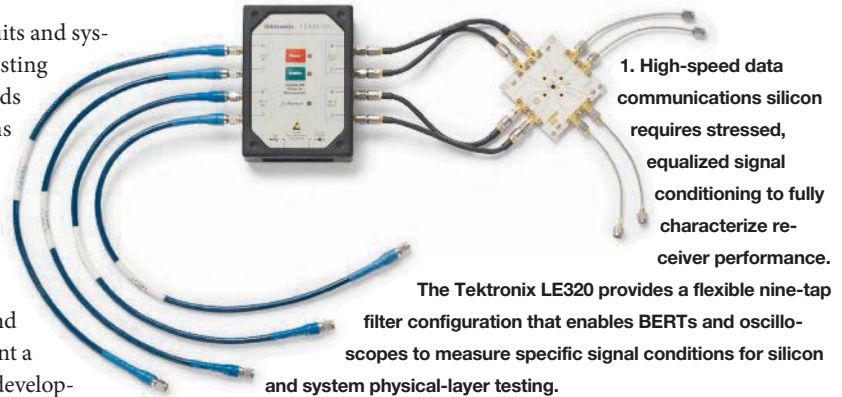

**1. High-speed data communications silicon requires stressed, equalized signal conditioning to fully characterize receiver performance.**

**The Tektronix LE320 provides a flexible nine-tap filter configuration that enables BERTs and oscilloscopes to measure specific signal conditions for silicon and system physical-layer testing.**

For electrical 4x25G testing of chipsets, transceivers, or systems, a standard set of instruments is used. For signal generation, either the PPG3204 pattern generator or the BSA286C BERTScope can be used. The test signal is then sent to the new LE320, a 32-Gbit/s, two-differential channel, nine-tap linear equalizer, for receiver testing (*Fig. 1*).

The device under test (DUT) gets the LE320 enhanced signal. The DUT output goes to one of several display options: the PED4000 error detector, BSA286C BERTScope, or DSA8300 sampling oscilloscope. Software for analysis includes the JMAP bit error rate (BER) contour and jitter analysis, the 80SJBN jitter and timing analysis, or the CEI-VSR compliance test.

The need for 4x25G testing is becoming more important as the industry moves from silicon design to transceiver and system design. Designers are creating network elements that allow data rates up to 100 Gbits/s, which will be delivered using four lanes of 25 to 28 Gbits/s. Design challenges emerge when transmitting these high frequencies on printed-circuit boards (PCBs), even for short distances.

The key to successfully testing such systems is the LE320, which provides test engineers with versatile output signal conditioning and tunable input equalization to create an optimal system for testing four electrical channels operating at 25 to 28 Gbits/s each. The Sampling Oscilloscope Option CEI-VSR will help to ensure efficient and consistent compliance testing support so designers can smooth the transition to manufacturing.

Designers developing systems that run at 10 Gbits/s or faster need an equalizer in front of receiver inputs or a pre-emphasis

# Gather, organize and control data like never before.



Agilent 34970A/72A Data Acquisition Switch Units (DAQs) have achieved market leadership for more than a decade. Perhaps it's the 34970A/72A DAQ's unmatched capability. Or the 34972A DAQ's ability to control everything remotely via mobile interface. Or the BenchLink Data Logger software that lets you scan, monitor, control and analyze your data so you can quickly act on it. Maybe it's all of the above.

34972A DAQ	34970A DAQ
3-slot LXI unit with built-in 6½ digit DMM	
USB and LAN	GPIB and RS-232
Graphical web interface	—
\$1,952*	\$1,690*



See a 34972A product overview. Scan or visit: <http://qrs.ly/5i3fkxg>

**Agilent and our Distributor Network**  
Right Instrument.  
Right Expertise.  
Delivered Right Now.



**microlease**

866-436-0887  
[www.microlease.com/agilent](http://www.microlease.com/agilent)

Learn more with our library of measurement briefs, videos and more  
[www.microlease.com/agilent/daq](http://www.microlease.com/agilent/daq)

© Agilent Technologies, Inc. 2013  
\* Prices are in USD and are subject to change

Anticipate — Accelerate — Achieve



**Agilent Technologies**

module on transmitter outputs. As speeds increase, designers have had a limited selection of signal conditioning products beyond 12 Gbits/s for meeting these requirements.

The LE320 supports signal conditioning on data rates from 8 to 32 Gbits/s in a nine-tap design used to deliver the high-precision error rate testing required by 100G communication standards like CEI-28G-VSR. Its remote head design enables designers to minimize cable length in their test system and avoid signal degradation issues, which are significant at 25 to 28 Gbits/s. With programmable equalization, the LE320 can be configured to provide standards-specific equalization, permitting BER analysis on otherwise closed eye signals.

Multi-lane, high-data-rate standards are driving the need for multi-channel BER instruments. Stressed receiver tests, four-channel end-to-end BER testing, and cross-talk tests are now among the suite of tests driven by the move to multiple high-speed parallel lanes.

Jitter measurements are also a major part of 100-Gbit/s electrical testing. The Tektronix PPG/PED line of multi-lane BER testers (BERTs) has been enhanced to provide expanded jitter impairment capability, new output adjustment flexibility, and higher-speed error detection capability to better meet the requirements of these standards.

The extended range of jitter insertion options includes option HFJIT, which now provides BUJ as well as RJ and SJ; and

high-amplitude/ low-frequency PJ as part of new option LFJIT. Option ADJ adds adjustable outputs with fast rise/fall time and low intrinsic jitter required for 32-Gbit/s multi-channel pattern generator applications. The PED4000 series of error detector products, which are capable of data rates of up to 40 Gbits/s in one- or two-channel configurations, has enhanced data-rate margin testing.

The IA for OIF CEI 3.0 specifies the tests and limits for devices based on OIF standards. CEI-28G-VSR, which is one of those standards, is intended for use in very short-reach electri-

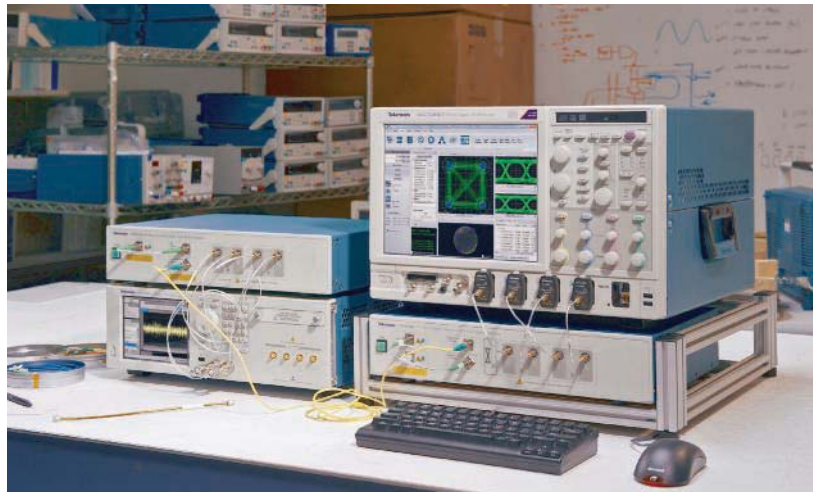

**2. Tektronix's complete end-to-end solution for testing 100G/400G coherent modulation systems comprises the OM5110 optical transmitter and AWG70001A arbitrary waveform generator pair (left), which together provide a greater than 32-Gbaud modulated test signal output, and the OM4106D optical modulation analyzer and MSO73304DX 33-GHz oscilloscope (right), which provide a complete coherent modulation analysis system.**

# From entry level to high performance. Oscilloscopes from the T&M expert.

Fast operation, easy to use, precise measurements – that's Rohde & Schwarz oscilloscopes.

R&S®RTO: high performance (Bandwidths: 600 MHz to 4 GHz)

R&S®RTM: upper midrange (Bandwidths: 350 MHz and 500 MHz)

HMO3000: midrange (Bandwidths: 300 MHz to 500 MHz)

HMO: entry level (Bandwidths: 70 MHz to 200 MHz)

All Rohde & Schwarz oscilloscopes incorporate time domain, logic, protocol and frequency analysis in a single device.

Take the dive at [www.scope-of-the-art.com/ad/all](http://www.scope-of-the-art.com/ad/all)



cal channels in pluggable optical transceivers. These electrical interfaces must be able to meet system BER targets and undergo rigorous testing and debug cycles.

Until now, performing all the required tests for CEI-28G-VSR compliance and isolating problems related to jitter or noise has been difficult and labor intensive. Integration with Tektronix 80SJNB serial data link analysis software enables deeper debug and timing root cause analysis without the need to move to a different instrument or measurement setup.

By using Option CEI-VSR with the Tektronix DSA8300 sampling oscilloscope, design engineers can perform compliance measurements in less than 5 minutes, reducing their testing time by approximately 95% compared to manual alternatives.

### 100/400-GBIT/S OPTICAL TESTING

High-speed optical networking is increasingly being used for short-reach data-center applications. This is creating a need for test equipment to support analysis of multi-mode, 850- and 1310-nm signals found in 100Gb (4x25) Ethernet systems.

For long-haul applications, designers are now turning to coherent modulation techniques to get the most from available fiber bandwidth. This is creating a need for test systems to help ensure optimum performance and low BERs using formats such as dual-polarization quadrature phase shift keying (DP-QPSK), polarization-multiplexed QPSK (PM-QPSK), and polarization-multiplexed 16-phase quadrature amplitude modulation (PM-16QAM).

To address this problem, the 32-GHz 80C15 multi-mode optical sampling module for use with DSA8300 series sampling oscilloscopes provides high-quality acquisition of 850- and 1310-nm multi-mode signals. With a tightly controlled

frequency response, the module enables repeatable automated compliance testing for all of the short-reach standards ranging from 22 to 32 GHz.

The combination of a DSA8300 series mainframe and an 80C15 multi-mode optical sampling module delivers ultra-low instrumentation noise and phase noise (jitter) for <100-fs RMS electrical and optical jitter measurements. It delivers the test margin needed to accurately measure the low-power signals used in short-reach applications. It also supports mask testing including mask margins based on standard specified hit ratios.

For long-haul applications, the OIF's DP-QPSK technique over single-mode fiber is the de facto standard using the optical transport network (OTN) protocols. DP-QPSK is a modulation technique that effectively quadruples the data rate over standard on-off keying (OOK) of the laser in systems using 10 Gbits/s or less.

QPSK transmits two bits per symbol or baud as it combines two carriers of the same light frequency with a 90° phase shift between them. Then the two QPSK signals are multiplexed on a single fiber by transmitting one QPSK signal with a horizontally polarized orientation and another QPSK signal is transmitted with vertical polarization. The combination of QPSK and dual polarization produces a fourfold increase in data rate over OOK, allowing a lower clock rate at 25 GHz to be used.

The receiver uses coherent demodulation, meaning the DP-QPSK signal is mixed with a local oscillator signal at the clock frequency allowing the receiver to sync in both frequency and phase to recover the bits. This coherent detection also helps mitigate optical impairments like chromatic and polarization mode dispersion. Additionally, it improves the signal-to-noise ratio, allowing longer fiber reaches to be used.

Save up to **40%**  
on a new scope now!

Special Trade In Program  
available until June 2014;  
[www.scope-of-the-art.com/ad/trade-in](http://www.scope-of-the-art.com/ad/trade-in)



The AWG70001A arbitrary waveform generator generates the signal in the test setup for long-haul coherent modulation testing (Fig. 2). The PPG3204 32-Gbit/s pattern generator also may be included. The generated signal is sent to the OM5110 multi-format optical modulator and transmitter. The transmitter drives the fiber cable to the receiver, the OM4106D coherent lightwave signal analyzer.

The output is viewed on the DPO73304DX digital phosphor oscilloscope. The MSO73304 33-GHz oscilloscope also may be used. The OM1106 optical modulation analysis software analyzes the signal. Once the setup has been adjusted, the transmitter or the receiver is replaced with the device to be tested.

For long-haul optical research and development applications, the OM5110 modulates all common formats including binary

phase-shift keying (BPSK), PM-QPSK, and PM-16QAM up to 46 Gbaud with fully automated and manual bias control of the modulator and RF amplifiers, giving users complete configurability and versatility. With the introduction of the OM5110, Tektronix is the only test and measurement vendor that offers a complete coherent optical test system from signal generation to modulation, acquisition, and analysis.

The OM5110 offers built-in C or L band lasers along with support for external lasers. Automatic bias control allows for quick setup and easy operation of the modulator, while the manual bias control capability enables users to take control of all bias voltages for testing specific scenarios.

The AWG70001A 50-Gsample/s arbitrary waveform generator and the OM5110 make up a complete coherent optical signal generation system that's ideal for the design of the most effective coherent modulation formats. By adding an optical modulation analyzer and oscilloscope, such as the OM4106D coherent lightwave signal analyzer and DPO73304DX digital phosphor oscilloscope, engineers have access to a complete, end-to-end coherent optical test system.

The next challenge is testing systems beyond 100 Gbits/s. Already in demand, new standards and products for 400 Gbits/s, 500 Gbits/s, and 1 Tbit/s are being developed. These rates will be achieved with multiple wavelengths multiplexed on a single fiber. New systems will use two, five, eight, or 10 light carriers using coherent modulation schemes like DP-QPSK or DP-16QAM. Formal standards have yet to be set. Tektronix's optical test systems can support that coming challenge. **ed**

**More than 3,000 electronics R&D and manufacturing enterprises' choice**  
 THE LEADING MANUFACTURER OF HIGH-TECH QUICK TURN PROTOTYPE, HIGH MIX, LOW AND MEDIUM VOLUME PCB'S IN CHINA AND WORLDWIDE.

**Why you should choose FASTPRINT**

- Same day response, 24 hour quotes, daily project updates and a technical service staff.
- 10+ years' experience in the leading edge technology SemiTest industry.
- The varieties of product exceed 15,000 per month, leading the world.
- Quick turn Lead-time specialists.
- Ensure Zero risk policy through local on-site quality design Support & Test.
- Turnkey Solutions (CAD support – PCB fabrication – Assembly) effectively reducing delivery cycles times.

**Expanded Capabilities**

- Layer count up to 46 layers
- Min line width/spacing: 2.5/ 2.5 mil
- Max aspect ratio 30:1
- Min mechanical drill size 6 mil
- Min Spacing between via to Conductor 4mil
- Conductive and Non-Conductive Epoxy Fill
- Blind and buried vias
- Embedded Capacitor/Resistor



**FASTPRINT**  
 www.chinafastprint.com

Add: 3375 Scott BLVD Suite 139 Santa Clara CA 95054  
 Tel: (408)-550-2903 (408)-550-2908  
 Email: sales-us@chinafastprint.com





**BY 2017, MOBILE DEVICES  
WILL STORE OVER  
64 BILLION GAMING APPS.**

Be ready with the storage  
that's ready for the future.

The universe of apps is exploding. Mobile downloads are skyrocketing. And the need for storage has never been greater. That's why for 25 years, SanDisk has been expanding the possibilities of storage and enabling companies to create game-changing products. [sandisk.com](http://sandisk.com)



[www.mouser.com](http://www.mouser.com)

The Newest Products for Your Newest Designs®



ORE.

[mouser.com](http://mouser.com)

The widest selection  
of the newest products.



Authorized distributor of semiconductors  
and electronic components for design engineers.



**MOUSER  
ELECTRONICS**





1. Wearable technology, 3D printing, and robotics are three emerging technologies that supply chain companies should focus on in 2014, said author and futurist Jack Uldrich of the School of Unlearning. (photo by Curtis Elzey)

## 5 Issues Shaping The Electronics Supply Chain

In 2014, electronics industry executives will look to emerging technologies for growth while focusing on student-centered investment opportunities and keeping counterfeit parts out of the supply chain.

**A SHOW OF HANDS** at a recent electronic components industry meeting confirmed what many executives are feeling as 2013 comes to a close: the flat to only slightly up business conditions that have characterized the electronics supply chain for the last two years are going to stick around for a while. Only about a third of the executives listening to an economics presentation at the

Continued on Page 40

## Energy Markets Stay Strong

Rising domestic oil and gas production and a continued focus on energy-efficient electronics fuel distributors' growth in energy markets.

**THE ENERGY PORTION** of TTI's industrial business has been a bright spot on the economic horizon and is likely to continue on that path, according to Lew LaFornara, vice president of supplier relations for the company. Industrial markets have been a mixed bag recently, he explains. But with an increase in domestic oil and gas exploration and new production techniques causing growth in both areas, companies selling to those customers are seeing steady increases.

Indeed, domestic oil and natural gas production is rising, causing many suppliers to sharpen their focus on traditional energy markets. Shale oil production in particular is set to jump by nearly a third this year to 3.3 million barrels a day due to new extraction techniques. Economist Jack Ablin, who spoke to distributors and manufacturers at the recent ECIA Executive Conference in Chicago, pointed to the growth as a key positive sign on the economic landscape.

Continued on Page 44

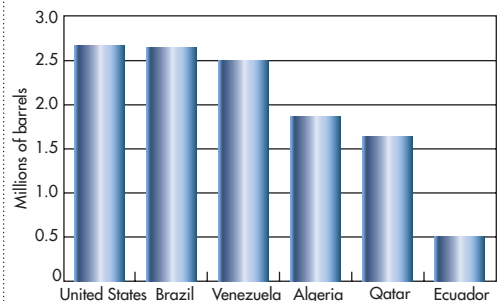

**Oil production in the United States grew by nearly 2.7 million barrels a day to reach more than 11 million barrels a day from 2008 to 2012. This increase surpasses the total oil production of other leading countries.**

(courtesy of IER, <http://www.eia.gov/countries/index.cfm?view=production>)

## 5 Issues

Continued from Page 39

Electronic Components Industry Association's Executive Conference in Chicago in late October raised their hands when asked if they thought their companies would finish 2013 with higher sales than 2012.

This is new to an industry in which growth tends to outpace the general economy, and it's leaving many looking for new strategies that will help them better compete in a changing business climate. ECIA's annual conference tackled the issue with the theme "Shift Happens" and presented a slate of speakers from inside and outside the industry offering insight on how manufacturers and distributors of electronic components can navigate the change and still meet buyers' and design engineers' growing list of demands.

The ECIA audience of distributors, manufacturers, and manufacturer representatives covered a big slice of the electronics marketplace. Presenters discussed everything from new market opportunities to honing your supply chain niche. Their advice provided a roadmap of where component suppliers will be looking for growth and offers a glimpse at areas the supply chain of the future will focus on. Here are five of them.

### 1. EMERGING TECHNOLOGY

Component suppliers are always looking for "the next big thing" that will shake up the electronics industry, but such innovations have been elusive in today's flat market. Still, companies should keep some key product trends on their radar screens, said Jack Uldrich of the School of Unlearning on the first day of the conference (Fig. 1).

Wearable technology is one area. Uldrich told attendees that it "absolutely could be" a huge market in the not too distant future, pointing to the wearable computer Google Glass as an example. The convergence of wearable technology and mobile health monitoring is another big area, according to Uldrich. He noted a wide range of fitness and health-monitoring devices, such as the FitBit

activity tracker, a wireless-enabled wearable device that measures a range of personal health metrics. Uldrich also cited 3D printing and GE's goal to produce jet engine parts using the technology by 2016, as well as robotics, a hot area for U.S. manufacturers.

"This technology is getting exponentially better," Uldrich said of 3D printing in particular.

### 2. THE INTERNET OF THINGS

The Internet of Things is all about connectedness—connecting people, processes, and things to the Web. It's a



2. "[FIRST] turned my life around. It inspired me to try harder in school. I knew I couldn't become an engineer with a 2.7 GPA," engineering student Tim Balz told attendees at an electronics industry conference in late October. (photo by Curtis Ellzey)

growing opportunity for companies of all kinds, according to Uldrich and Intel's Rick Dwyer, who also spoke at the ECIA conference.

To put it in perspective, Dwyer said that as of late October, there were 10.7 billion people, processes, and things connected to the Internet—an impressive installed base of potential business that will only grow. The key to capitalizing on this potential is figuring out how to sell the services and solutions people need to enable their projects, programs, and ideas, Dwyer said.

"What can we do differently to capture the value of the Internet of Things?"

he urged companies to ask. He also described opportunities in the Smart Grid as a prime example, as utility companies look for new ways to manage and analyze energy use and spending, opening the door for companies that sell devices and technology that will allow them to do so in an online environment.

### 3. HONING YOUR NICHE

Finding your place in a changing market is one of the most difficult parts of being in business, but it's nothing new if you ask Steve Fisher, CEO of Philadelphia-based specialty distributor PEI-Genesis. In a presentation focused on business evolution and the importance of maintaining a "culture that cares and values that matter," Fisher recounted his family-owned firm's evolutionary journey from a small startup distributor of electronic parts to one of the world's leading assemblers of precision connectors and power supplies.

Founded in 1946 by Fisher's father, Murray Fisher, and his best friend Bernie Bernbaum, PEI-Genesis has been honing its niche as an international manufacturer, assembling distributor, and engineering design firm for connectors and power supplies ever since. But today's difficult economic times are presenting new challenges. After years of consistent growth, Fisher said PEI-Genesis has struggled to grow over the last 18 months. But he advised that tough times are an opportunity to look in the mirror and ask if you are still relevant and then make the changes necessary to remain so.

Careful evaluation of business trends and internal capabilities has led PEI-Genesis to its place as a high-mix product business that builds more than 10 million connectors a year, Fisher explained. And though he didn't say exactly what's next for the firm, he emphasized that changing with the times while holding on to the values of its founding fathers will be a driving force in the company's ongoing evolution. He suggested that all supply chain companies should use a similar guiding light in today's shifting economy.



# SIMPLIFIED.

## SUPPLY CHAIN SOLUTIONS FROM AVNET

Your job is to develop and market innovative products; our job is to reduce your risk along the way.

Even leading edge products need a cost-effective and dependable supply chain to be a success. That's where Avnet can help. Around the world and around the clock, you can rely on our expertise at every point in the supply chain - from supply chain assessment to solution design to global planning.

Avnet's supply chain solutions save you inventory and infrastructure. That's money in the bank, and the edge you need to stay ahead of the competition. Simple, really.

What can we do for you? [www.avnetexpress.com](http://www.avnetexpress.com)

Accelerating Your Success!™

1 800 332 8638 | [www.avnetexpress.com](http://www.avnetexpress.com) |   @avnetdesignwire



#### 4. INVESTING IN THE FUTURE

In one of the most inspiring presentations of the ECIA event, and the only one to receive a standing ovation, teenager Tim Balz explained how the FIRST science and technology program changed his academic life and put him on the path to becoming an engineer and entrepreneur (Fig. 2). His talk served as a wake-up call about the importance of investing in students to ensure a more successful electronics industry in the future.

Balz is a freshman at the Rose-Hulman Institute of Technology in Indiana. Yet he said he wouldn't be there if it weren't for FIRST—For Inspiration and Recognition of Science and Technology, a program that encourages elementary, middle, and high school students to develop their science, engineering, and technology skills through teamwork and competition.

Schools throughout the country form FIRST teams that are sponsored by teachers, community volunteers, and corporations. The teams are charged with building a robot that can perform a specific task in a series of competitions held across the country. Corporate sponsors play a large role in supplying the electronic components, tools, and other products students need to build their robots.

Balz emphasized the need for industry involvement in the program by telling his compelling story. A motocross rider with a 2.7 grade point average, Balz had little interest in academics until one of his teachers asked him to join his school's FIRST program in his sophomore year. He quickly became a team leader, and before he was out of high school he had founded Freedom Chairs, a non-profit organization that recycles and rebuilds powered wheelchairs for people in need of mobility. The 18-year-old is president of Freedom Chairs, which is staffed by a team of student volunteers from Balz's alma mater, Plainfield High School.

"[FIRST] turned my life around," Balz told attendees. "It inspired me to try harder in school. I knew I couldn't become an engineer with a 2.7 GPA."

Balz finished with a 3.65 GPA.

#### 5. STANDING UP TO COUNTERFEITS

Despite recent efforts to reduce the threat of counterfeit electronic components entering the market, the situation is not getting much better, according to Avnet's Ed Smith, who made the subject a centerpiece of his presentation. Smith, who is president of Avnet Electronics Marketing Americas, warned of a misunderstanding among customers about the meaning of authorized distribution and called for a campaign to educate buyers about the dangers of sourcing components from the open market.

Although counterfeit parts can find their way into authorized distributors' inventory through customer returns, independent distributors and brokers represent the greatest threat because they do not purchase components directly from the original manufacturer. Many independents specialize in obsolete and hard-to-find parts and invest in testing and purchasing programs designed to detect counterfeits and keep them out of the supply chain, but only authorized distributors receive components directly from original component manufacturers.

Smith discussed efforts by authorized distributors to address the counterfeit problem, including supply chain management programs, design support, product obsolescence programs, and aftermarket support designed to help customers avoid turning to the open market. He also said it's time to hold customers accountable for their role and urged new regulations that hold buyers responsible for purchasing counterfeits by making it a criminal offense.

A bad part can cause military equipment to fail on the battlefield, putting soldiers' lives in danger, Smith said. Bogus parts in the commercial market are dangerous as well, as a faulty medical device or commercial jet system puts everyone in danger. In addition to emphasizing the need for ongoing involvement by authorized distributors, Smith's points represent another attempt to keep the issue front and center in an increasingly complicated economic landscape. ●

## NAND Flash Memory Market Decelerates

But the sector will still hit record revenue this year of \$24 billion.

**GROWTH IN THE** global NAND flash memory market is slowing in the second half of 2013 following diminishing demand for local data storage in smart phones and tablets, due in part to the rise of cloud-based devices, according to a new market research report from industry researcher IHS Inc.

NAND bit shipments were set to grow 8% in the third quarter according to early estimates. That's down from 9% in the second quarter, IHS reports, and will be followed by an even lower 5% in the fourth quarter. Fourth-quarter growth will be down sharply compared to the year-earlier period, when the market grew 16%.

"The fast-growing season for flash memory appears to be running out of momentum as density growth levels off in many of the products that are leading users of NAND," says Ryan Chien, storage systems analyst at IHS. "Moreover, few upcoming devices are expected to increase their NAND options, further dampening growth in the short term."

Despite the second half, IHS is projecting a record year in both shipments and revenue for the NAND flash industry in 2013, with 39 billion Gbytes of shipments and \$24 billion in revenue.

IHS points to cloud storage, growth in low-end smart phones with limited NAND use, and consumer indifference to NAND-heavy devices like game consoles, PCs, e-readers, and USB drives as key reasons for the slowing market.

"Streaming media options and free cloud storage are diminishing the prospects for increased NAND usage in smart phones," Chien says. "This is true for all three major mobile operating sys-

# READ NOW!

AND SIGN UP TO GET YOUR FREE PRINTED COPIES OF THIS EXPLOSIVE SERIES!



ONLY AT [TTIINC.COM/THE SPECIALIST](http://TTIINC.COM/THE SPECIALIST)



READ THE SPECIALIST'S COMPLETE ORIGIN STORY AND SEE WHY SETTLING FOR ANYTHING LESS THAN OUR INDUSTRY-LEADING CUSTOMER SERVICE AND AUTHENTIC PARTS WOULD BE A CRIME!

1.800.CALL.TTI

## NAND Flash Memory

Continued from Page 42

tems—Apple’s iOS, Google’s Android, and Microsoft’s Windows Phone.”

NAND prices are rising despite the slowdown in usage. IHS points to a small supply chain disruption due to a fire at South Korean memory supplier SK Hynix in Wuxi on September 4. The incident caused the manufacturer to shift some of its NAND capacity to DRAM and opened the door to possible supply chain challenges down the line.

Formulated to keep track of movements in NAND pricing over time, the IHS NAND price index has jumped nearly 10% since the fire, signaling some nervousness in the market. But as demand concerns have started to weigh on the market, prices have drifted over recent weeks, according to IHS.

### NEW PRODUCTS

NAND products continue to make their way to the market. For example, Toshiba’s new embedded NAND flash memory modules integrate NAND chips that are fabricated with the company’s 19-nm second-generation process technology and comply with the latest e-MMC 1 standard.

Designed for application in a wide range of digital consumer products, the modules target smart phones, tablet PCs, and digital video cameras. The lineup of single-package embedded NAND flash memories includes densities from 4 to 128 Gbytes. Each device integrates a controller to manage basic control functions for NAND applications.

Kingston Technology’s SSDNow mS200 mSATA solid-state drive offers a cost-effective performance boost with a dual-drive option that allows room for adding high-capacity storage in capacities up to 120 Gbytes. Ideal for system builders, OEMs, and enthusiasts, the mS200’s miniscule form factor is eight times smaller than a traditional 2.5-in. hard drive, making it ideal for notebooks, tablets, and ultrabooks. ●

## Energy Markets

Continued from Page 39

“We are moving toward energy independence,” Ablin said, pointing to new hydraulic fracturing, or “fracking,” techniques many U.S. companies are using to reach areas previously unable to be drilled. “U.S. domestic production of crude oil and natural gas is rising. And innovation in the private sector is leading the way.”

Combined with ongoing efforts aimed at energy efficiency in both consumer and industrial circles, energy-focused distributors are betting on such innovations to drive growth into 2014.

### FOCUSING ON OIL AND GAS

In the past four years, U.S. oil and natural gas production has increased by nearly 2.7 million barrels per day to more than 11 million barrels per day, according to the Institute for Energy Research (IER), which calls the growth “impressive.” In a report published earlier this year, IER said the increase alone equals more oil than the total production of Brazil, Venezuela, Algeria, or Qatar (*see the figure*).

American companies that supply the oil and gas industry are taking note. This summer, distributor PEI-Genesis created a new position aimed at growing its energy-related business, naming Mike Brawner oil and gas business development manager for North America. PEI-Genesis says the new position will help expand its work with harsh-environment and explosion-proof connector brands as well as its proprietary explosion-proof cable assemblies.

“This new role is strategic to the long-term development and growth of the North American oil and gas market,” said Dave Jones, director of global sales at PEI-Genesis. “Based in our Houston office, Mike will be local to our customers and suppliers to help us develop the rest of the Gulf region.”

As further evidence of energy market growth, Ablin pointed to the increase in

natural-gas powered vehicles during the recent ECIA conference. Nationwide, more trucking companies and shuttle bus providers are turning to natural-gas powered vehicles, he said.

This fall, for example, logistics provider UPS expanded its use of natural-gas powered vehicles with a deal to purchase liquefied natural gas (LNG) fuel from an Indiana startup company to power 1000 of its semitrailer trucks in use throughout the Midwest. UPS has used LNG fuel in its fleet since 2000 and added 48 new LNG trucks to its long-haul network just two years ago.

### EFFICIENCY REMAINS A PRIORITY

Conservation and energy efficiency continue to drive strength in the energy sector as well. Many distributors point to consumer and industrial demand for energy-efficient lighting solutions and technology related to smart homes and businesses as key growth areas.

“I don’t know of a company today in any industry that isn’t focused on conserving energy,” says Lindsley Ruth, executive vice president of distributor Future Electronics.

Ruth notes the large amount of energy consumed in electronics, which causes a long-term focus on energy reduction and efficiency among component makers and distributors. A key market is lighting, where a shift continues from traditional sources to LED technology. Also growing in importance are devices focused on smart homes and offices. Technologies that help homeowners control heating, air conditioning, electricity, and security systems remotely, for example, are increasingly in demand.

Another way to conserve energy is through the use of wireless technology and extended battery life. Ruth calls this “a tremendous challenge and opportunity within the electronics space.”

Future has developed targeted efforts to serve both markets. Its Future Energy Solutions and Future Lighting Solutions groups provide sales and service resources for those markets. ●

# The NEW engineering tv

The place where engineering videos gather



Recent Videos



Engineering Channels

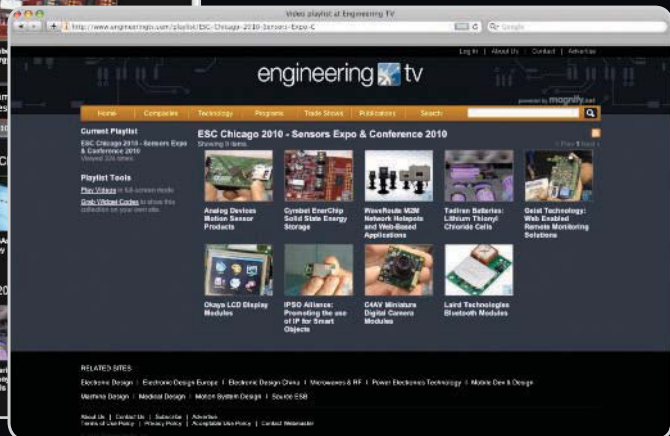

Trade Show Coverage

## THE SAME GREAT VIDEO CONTENT, IN AN EASY-TO-BROWSE FORMAT

In the past, we've been told by our design engineers that **Engineering TV** is their favorite place to "geek out." Well get your computers ready, because **Engineering TV** is all new and completely redesigned!

Browsing the most compelling videos is easier than ever. Our new engineering channels

let you explore the technologies that are of interest to you – everything from Aerospace to Embedded to Robotics. Plus, we film at all the key electronics and design engineering trade shows, so even if you can't attend, you can find out everything that is happening at these important events.

# CHECK US OUT TODAY: [www.engineeringtv.com](http://www.engineeringtv.com)



# Kickstarter Changes How Consumer Ideas Turn Into Gold

**KICKSTARTER HAS FUNDAMENTALLY CHANGED** how consumer products are developed and delivered, including embedded computing products. If you haven't heard about Kickstarter, you probably have been staring at your pet rock too much.

The site generates cash for startup projects from people interested in supporting them. The projects can range from TV shows and movies to 3D virtual reality platforms. The ultimate goal is to create enough cash to build a product or support an endeavor. Project supporters benefit as well. For example, they may be first in line for the product once it's finally released.

Projects must meet a monetary target within a specified timeframe. Supporters pledge money via credit card, which is charged only if the project exceeds its monetary goals. The project creators receive most of the money, and Kickstarter gets a cut. Projects that don't reach their goal within the specified time are closed, and the supporters' credit cards are not charged.

## SUCCESSFUL KICKSTARTS

Some projects have been very successful and popular, moving from ideas into the marketplace.

The wireless, e-paper Pebble watch from Pebble Technology is now available at Best Buy, and it isn't the only smartwatch funded through Kickstarter (Fig. 1). The Square smart-phone credit card reader, which costs just 2.75% per swipe, was kickstarted too.

Kickstarter isn't limited to consumer electronics. My daughter funded her Project Ninja Panda Taco game via the platform (see "Is Kickstarter The New Way To Get Capital?" at [electronicdesign.com](http://electronicdesign.com)). Even movies and events have been launched using it.

In the consumer electronics marketplace, three successful Kickstarter projects really stand out: the Virtuix Omni 3D VR platform, Oculus VR's Oculus Rift 3D glasses, and the Sixense STEM System 3D position sensor (Fig. 2).



1. The wireless Pebble smart watch from Pebble Technology uses an E Ink e-paper display.

Using an Omnivision OV9715 RGB camera and dual 204-MHz NXP LPC4330 microcontroller, the Pixie CMUcam5 from Carnegie Mellon University and Charmed Labs is another success (see "Tracking Movement Optically And Cheaply" at [electronicdesign.com](http://electronicdesign.com)).

The Pixie's open hardware design and open-source software will give robotic developers a flexible platform for experimentation (Fig. 3). The Pixie itself isn't a consumer electronics product, but it is a building block for developers who may eventually come up with an idea that could be turned into something solid via Kickstarter.

Gumstix's Kickstarter project for its Geppetto development platform is another example of building on Kickstarter (see "W. Gordon Kruberg Explains How To Kickstart A Gumstix" at [electronicdesign.com](http://electronicdesign.com)). Geppetto is a high-level, Web-based board design tool with one function: create a carrier board for Gumstix modules.

Normally a designer would use Geppetto to design a board and then order a bunch. There are startup costs plus the

2. Sometimes Kickstarter projects can play off of each other like Virtuix's Omni virtual reality platform, Oculus VR's Oculus Rift 3D virtual reality glasses, and Sixense's 3D position sensing controllers.



# Value Instruments: The quality you expect at an unexpected price.



High quality = high price? Not with our Value Instruments.

Value Instruments are versatile T&M instruments for everyday lab use.

- Quality T&M solutions engineered by Rohde & Schwarz
- Accurate, reliable, easy to use
- Comprehensive support thanks to the extensive service and technical support network

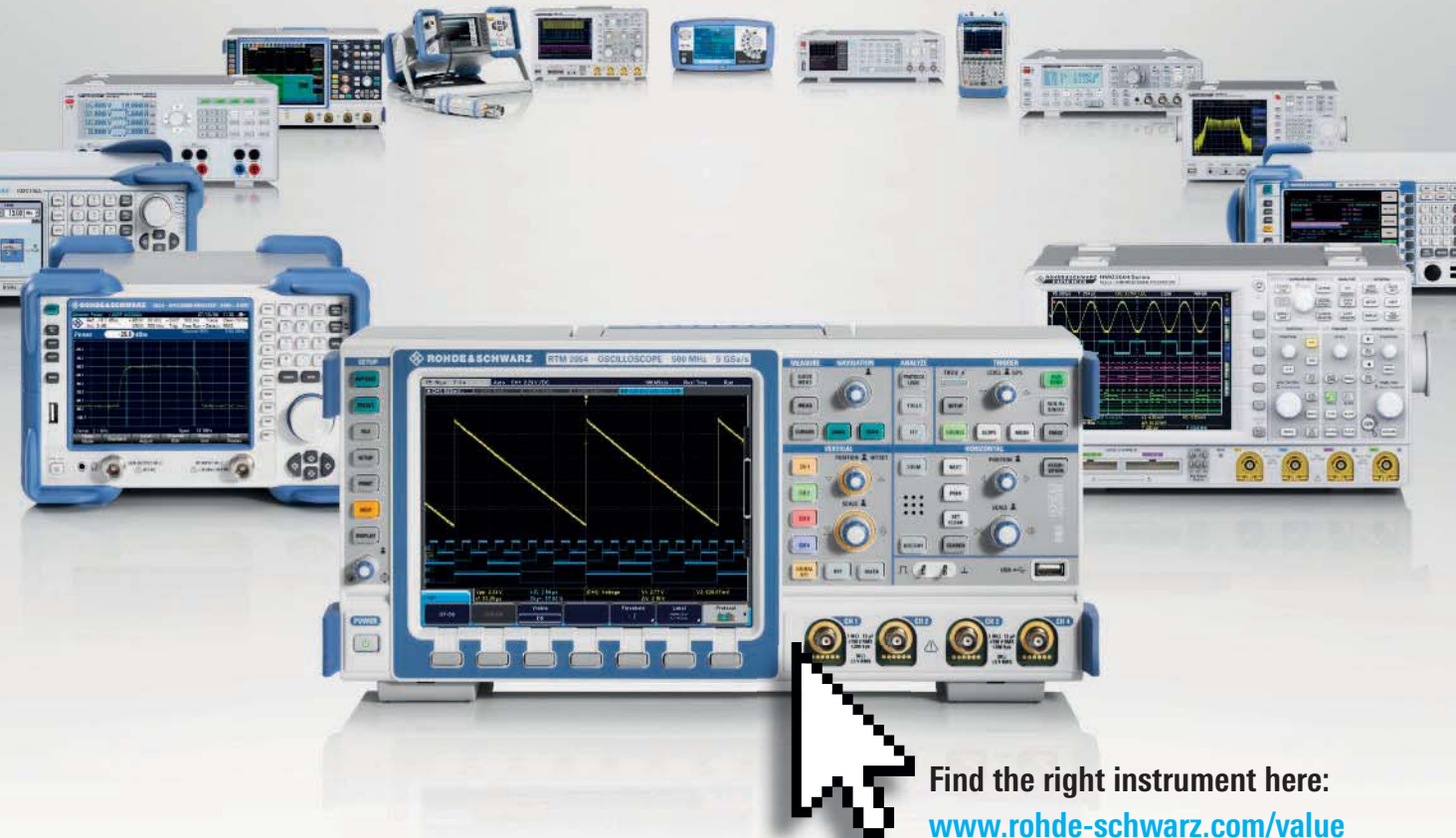

Find the right instrument here:  
[www.rohde-schwarz.com/value](http://www.rohde-schwarz.com/value)

cost per board. Gumstix has made it possible for a design to be made public as a Kickstarter project. Essentially it allows a minimum number of boards to be ordered by supporters where the startup costs are amortized among the initial group.

Some projects specifically target the consumer electronics market, like the Ouya (Fig. 4). Like the Sony PlayStation and Microsoft Xbox gaming consoles, this tiny gaming platform connects

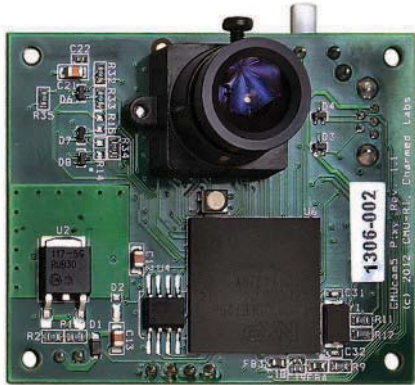

to HDTVs. The difference is the price—the Ouya costs less than \$100.

An NVIDIA Tegra 3 system-on-chip (SoC) powers the Ouya, which also runs Android. That's comparable to

3. The Pixie CMUcam 5 from Carnegie Mellon University and Charmed Labs uses an NXP dual-core microcontroller to give robots a visual experience.

higher-end smart phones and tablets. The Tegra 3 doesn't have the performance of the PlayStation and Xbox, but it does provide sufficient horsepower for more than 500 games. It can even be a video playback platform using the XBMC app. More are available each day.

Not convinced yet? Check out Kickstarter for the latest in consumer technology. It offers everything from mobile heart monitors to credit card readers and probably the next big thing in consumer electronics. [ed](#)



4. The Ouya game platform has more than 500 games that are free to try. It is based on NVIDIA's Tegra 3 SoC.

# HIGH VOLTAGE DIODES

HVCA offers a full range of high voltage diodes in many packages for any application. Custom items are available as well.

- 1 kV to 300 kV
- Fast Recovery down to 35nS
- Average Forward Current up to 10 Amps

**REPLACEMENTS FOR MANY FUJI DIODES AVAILABLE**

**HVCA**  
 (732) 938-4499 • (732) 938-4451 FAX  
 e-mail: [info@hvca.com](mailto:info@hvca.com)  
[www.hvca.com](http://www.hvca.com)

**DEAN TECHNOLOGY**  
 HVCA Products by Dean Technology

## The Convenient All-in-One Solution for Custom-Designed Front Panels & Enclosures

**You design it**  
to your specifications using our FREE CAD software, Front Panel Designer

**We machine it**  
and ship to you a professionally finished product, no minimum quantity required

- Cost effective prototypes and production runs with no setup charges
- Powder-coated and anodized finishes in various colors
- Select from aluminum, acrylic or provide your own material
- Standard lead time in 5 days or express manufacturing in 3 or 1 days

**FRONT PANEL EXPRESS**  
[FrontPanelExpress.com](http://FrontPanelExpress.com)  
 1(800)FPE-9060



# Processors Boost Motor Control And PV Performance

**THE QUEST FOR GREATER ENERGY EFFICIENCY** envelops all market sectors. Probably no other segment of electronics can deliver greater returns in efficiency than industrial control. For example, electric motors consume 40% of the world's electric power, and most of those motors are used in industrial automation. Increasing labor costs are driving the increased use of factory automation and robotics as well.

The need for greater industrial motor power efficiency and performance has never been more significant. Developers of industrial drives are demanding lower power consumption, less torque ripple, and more precise speed control. The key to achieving these ends is higher precision analog conversion within the closed-loop control scheme.

Another factor is the increased use of photovoltaic (PV) equipment for alternative energy systems, which also are rated on their efficiency and performance. The key to the increased adoption of solar systems is improved efficiency. Solar PV has become the largest source of new generation capacity added to the global electricity grid, and it is set to become the fastest growing source of renewable energy generation over the next decade.

Increased measurement accuracy is required to meet ever-more stringent grid compliance requirements. Faster power control loops, fueled by the emergence of gallium-nitride (GaN) and silicon-carbide (SiC) power switching technologies, are combining with better accuracy to enable significant performance and cost improvements in the next generation of solar PV inverter topologies.

The Analog Devices ADSP-CM40x series improves efficiency and performance in motor control and PV systems via more precise control. The widely deployed three-phase permanent magnet (PM) motors use pulse-width modulation (PWM) to control speed and torque. The PWM signals are developed by a processor that in turn gets its inputs from a control program that's modified by feedback sig-

nals derived from the motor's voltage, current, and speed. The control algorithms ensure that precise outputs are developed so they adapt to fluctuations in system behavior in real time. These sensorless vector control techniques have been developed to simplify and improve system response at lower cost.

## THE PROCESSOR

The ADSP-CM40x family of mixed-signal control processors is based on the ARM Cortex-M4 processor core with a floating-point unit operating at frequencies up to 240 MHz and integrating up to 384 kbytes of SRAM memory, 2 Mbytes

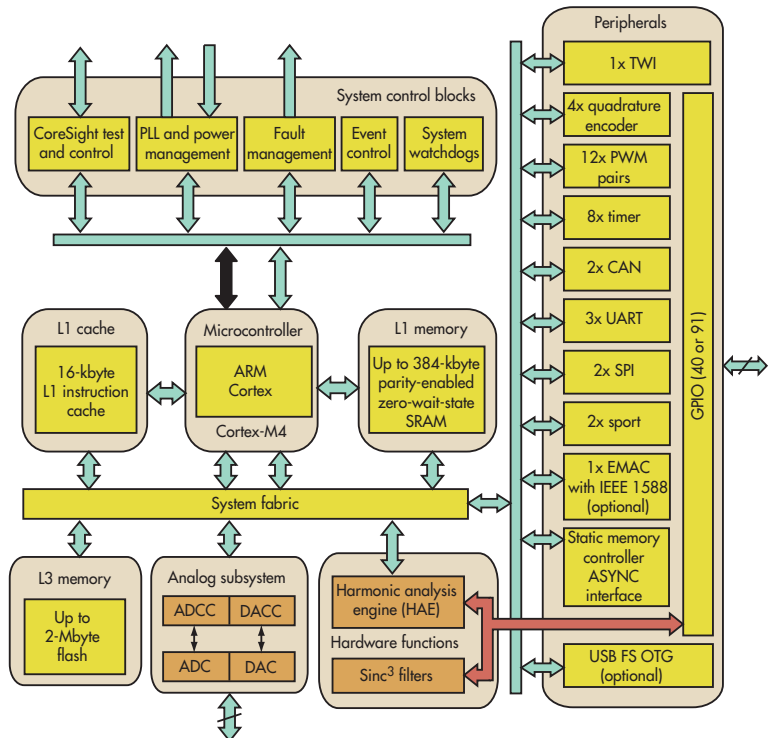

1. The Analog Devices ADSP-CM40x mixed-signal control processor integrates the industry's only embedded dual 16-bit ADC with up to 14 bits of accuracy together with a 240-MHz floating-point ARM Cortex-M4 processor core. The ADSP-CM40x comes in four versions. The CM402F and CM403F have 40 general-purpose I/O (GPIO) and come in a 120-lead low-profile quad flat package (LQFP). The CM407F and CM408F have 91 GPIOs plus USB and Ethernet and come in a 176-lead LQFP.

of flash memory, accelerators, and peripherals optimized for motor control and PV inverter control (Fig. 1). An analog module comprises two 16-bit SAR-type (successive approximation register) analog-to-digital converters (ADCs) and two 12-bit digital-to-analog converters (DACs). The processors operate from a single voltage supply generating its own voltage supplies using internal voltage regulators and an external pass transistor.

The series is the first of a new generation of mixed-signal control processors being developed by Analog Devices for precision control applications. In addition to its analog conversion performance and 380-ns conversion speeds, the ADSP-CM40x provides a full sinc filter implementation to interface directly with isolated sigma-delta modulators (AD7400A and AD7401A) that are used in shunt-based current sensing system architectures. The availability of an on-chip sinc filter eliminates the cost and engineering resources required to implement that function in an FPGA. Each ADSP-CM40x device features eight general-purpose timers with PWM output, three-phase PWM units with up to four output pairs per unit, two controller-area network (CAN) modules, one two-wire interface (TWI), and three UARTs.

**MOTOR CONTROL**

High-end industrial motors operate more efficiently and with greater high-speed and low-speed torque control when the motor drive can more precisely and dynamically control currents fed into the motor windings in a closed-loop system. This starts with more accurate/precise sampling of motor currents. Two common approaches to sampling motor currents are through magnetic Hall sensors or with current shunts.

In Hall sensors, the ADC integrated with the processor performs the conversion. The integrated ADC on the ADSP-CM40x provides up to 14 bits of accuracy with 380-ns conversion latency. Very precise current samples then can be made available to the current loop control algorithms very quickly within the control loop time, allowing for more sophisticated algorithms to calculate more precise PWM output settings that control the current that in turn drives the motor more efficiently, smoothly, and accurately.

Unlike Hall sensors, which are isolated, shunts are non-isolated sensor devices. So, you need an isolation barrier that's typically provided by a very precise sigma-delta modulator like

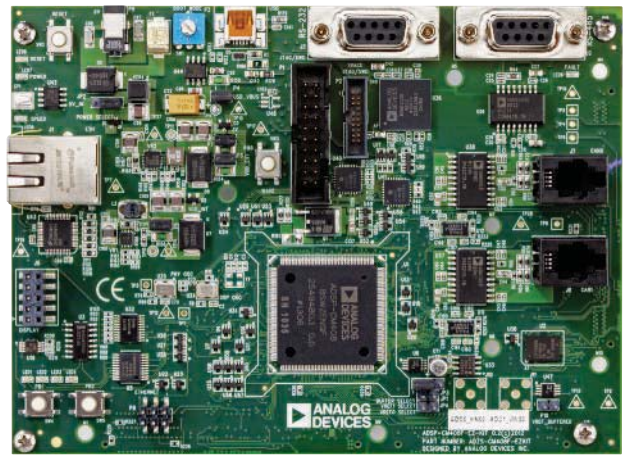

2. The ADSP-CM40x EZ-KIT board provides the basis for developing motor controls or PV inverters when combined with accessory boards and appropriate development software.

**Rittal – The System.**

Faster – better – worldwide.



**Thousands of enclosures  
Hundreds of sizes  
Next-day shipping**



ENCLOSURES

POWER DISTRIBUTION

CLIMATE CONTROL

the AD740x. However, a sigma-delta modulator produces a modulated digital bit stream that must be filtered and decimated by a sinc filter to produce the 16-bit samples that the control-loop algorithms can use. Typically these filters have been implemented in FPGAs, but the CM40x's integrated sinc filters perform this function without the need for an (expensive) FPGA.

ADI also provides software to produce model-based designs that minimize time-to-market by optimizing production code. This is done through the use of MathWorks' ARM Cortex-M optimized Embedded Coder and tool suites. Engineers can deliver designs from simulation to final code implementation in an embedded platform.

Through optimized code generation, device drivers, and compiler suites, engineers can plug their designs directly into an environment for model-based design using MATLAB and Simulink software, streamlining the workflow from system modeling to controller deployment to verification and certification, greatly speeding the development process.

#### SOLAR DEVELOPMENT

The ADSP-CM40x also provides a high-performance signal chain solution for today's modern, grid-tied solar PV Inverters. This mixed-signal control processor integrates the floating-point ARM-Cortex M4, which can accept up to 24 channels of analog sense inputs with 16-bit precision analog-to-digital conversion. On-board memory supports both the dc-dc boost stage and the dc-ac inverter stage.

The ADSP-CM403 integrates a highly capable PWM controller with up to 20 outputs along with ADI's advanced isolated gate drivers and optional sigma-delta shunt-based current measurement for the grid side. Isolation between the dc and ac sides

as well as between machine and human interfaces is enabled with ADI's patented iCoupler digital isolation technology. This solution provides all the hardware, software, and signal processing capability needed to simplify and optimize system-level solar PV inverter designs.

The availability of more precise current and voltage samples enables more precise control loops in PV inverters. Analog-to-digital conversion speed is becoming equally as important as precision as control-loop frequencies are increasing to accommodate the faster switching speeds of more efficient power switches, including GaN and SiC devices.

ADC precision can always be improved with "averaging," which takes the average of multiple samples to produce a more accurate, average sample. But this is done at the expense of the sampling speed or conversion latency, which impacts control-loop timing requirements. The CM40x ADC can convert simultaneous samples every 380 ns while competitive solutions can take more than 2  $\mu$ s to produce an "averaged sample" that is still not as accurate as the CM40x sample at 380 ns.

PV inverters must also increasingly address grid compliance requirements. The CM40x's built-in harmonic analysis engine can provide efficient power spectrum analysis to enable the inverter to better match grid currents and with fewer harmonics.

Finally, ADI offers development kits to facilitate both motor control and PV development (Fig. 2). The CM40x EZ-KIT includes the processor and all of the related memory, I/O, and ADCs/DACs. Add to that a high-voltage power board with all the circuitry need to run a three-phase PM synchronous motor for development and testing. ADI also offers a solar PV inverter kit to complement the CM40x EZ-KIT for PV development projects. 



IT INFRASTRUCTURE

SOFTWARE & SERVICES

www.rittal.us





# Ultrasound Platform Opens Business Opportunities

**CEPHASONICS** offers an ultrasound platform that's well designed and getting smaller with each generation. But the company also has introduced a business model to sell and market products that serve very specialized niches.

Basically, Cephasonics turns customers into salesmen. That's more than having customers trumpet the virtues of their products. Cephasonics puts customers in charge of extending the product's utility within their own niches.

## CUSTOMERS FIND CUSTOMERS

Cephasonics' products range from rack-mount down to pocket-watch sizes that can make and deliver real-time ultrasound images to a PC, laptop, or tablet. In the classic business model, the company would conduct research, find a niche, and build a market by attending medical tradeshow and finding potential customers.

Instead, Cephasonics goes to shows and finds physicians with particular specialties who aren't intimidated by the prospect of writing code or having it written. Doctors who write their own code to fill their own needs alone, though, would waste a lot of time. Cephasonics addresses this conundrum as well.

Take an anesthesiologist who needs to provide proof that he performed a procedure to get paid for it by an insurance company. Sometimes, he delivers a very small amount of anesthetic to a very precise point in a patient's body. The needle goes in and is guided by an ultrasound device that also records an image of the delivery. A generic ultrasound device would not document the process automatically, though.

The Cephasonics platform enables the anesthesiologist to write code that matches the captured image to the patient, the time of day, and all of the documentation that the insurer requires. While this would help this particular physician, many other anesthesiologists are in similar situations. The doctor now can market the complete platform to other doctors with far more credibility than the best sales reps that Cephasonics can hire. The doctor shares in the profits from each sale as well.

Yes, the government will license each new instance of an application based on the same qualification data for the platform, which is somewhat simplified because the platform is battery-powered. You can guess what happens next when another doctor in a related field discovers what's going on. And while that's all happening in the medical arena, Cephasonics already is looking at non-destructive testing.

## HARDWARE AND SOFTWARE

Cephasonics started with the cQuest Cicada, a complete 64-channel ultrasound front-end system that connected on one end to an ultrasound transducer and on the other to a PCI Express or USB interface to a back-end host PC or laptop. Launched in 2012, Quest Ultrasound application programming interface (API) software offers the means of developing complete ultrasound-based products.

The API is a set of C++ libraries and header files providing user access to thousands of system parameters, and it could be used to acquire data from and control all Cephasonics cQuest Ultrasound platforms

while abstracting the underlying hardware. Version 3.0 of the API software supports multiple focal zones, full control of Doppler processing parameters, common imaging modes, and dual and quad parallel-beam processing.

Earlier this year, Cephasonics entered the ultrasound research market with the cQuest Griffin and cQuest Firebird research systems. In 1024-, 2048-, and 4096-channel configurations, the rack-mounted cQuest Griffin is the world's first commercial large-channel-count ultrasound research platform. The cQuest Firebird is a flexible and configurable 64-channel baseline ultrasound research platform in a desktop package. These products target institutions that are exploring new applications of ultrasound technology in capacitive micromachined ultrasonic transducers, unique-geometry transducers, elastography, and photoacoustics.

According to Cephasonics CEO and president Richard Tobias, the large-channel-count cQuest Griffin research system



The Cephasonics Dragonfly shrinks the embedded ultrasound host hardware into a 5- by 4.5-in. package.

allows researchers to conduct beam-formation research with large-element-count 2D matrix arrays that could translate into clinical breakthroughs.

"It provides an unrivaled ultrasound generator and data-acquisition system of up to 4k channels for RF or baseband operation with an optional beamformed B-mode path for positioning," he said. When research institutes are grappling with a difficult make-or-buy decision, the cQuest Griffin affords an enormous savings in development resources, time, and money, he added.

The Cephasonics hardware and software helps researchers by allowing them to use the familiar front-end MATLAB user interface while concentrating on ultrasound-research advancements. "Researchers can start writing code immediately on the compact, lower-cost cQuest Firebird and then switch once they take delivery of the larger-channel-count cQuest Griffin," Tobias said.

The cQuest Griffin comprises Nx128-channel transmitter modules that include delay and pulsing circuitry for each channel, Nx128-channel receiver modules that include time gain correction (TGC) and analog-to-digital conversion circuitry, and Nx128-channel DSP modules that include demodulation, filtering, and optional decimation.

An optional beamformed data path allows quick imaging or verification of probe placement. The acquisition, processing, and control blades are housed in a rack with the acquired ultrasound data available to the user via a shared memory interface.

#### SHRINKING PLATFORM

The Cephasonics cQuest Dragonfly is a complete 32- or 64-channel embedded-ultrasound host module in a standalone, 5- by 4.5-in. form factor (see the figure). The Dragonfly will also interface to an external host. It is intended to provide an easy and fast way to develop ultrasound-based products ranging from portable standalone imagers to application-

specific appliances, adding ultrasound capabilities to existing equipment in both medical and industrial applications.

Like its predecessors, the cQuest Dragonfly uses the cQuest Ultrasound API, providing a scalable development plat-

form across all of the company's hardware. The system hardware includes all the ultrasound-specific front-end transmit and receive analog, digital, and power circuitry along with an embedded miniature host computer module. 

## USB Embedded I/O Solutions

### Rugged, Industrial Strength USB



**16-Bit Multifunction Analog I/O, Up to 140-Channels  
500kHz**



**Isolated Digital I/O  
16 Inputs and 16  
Solid-State Relay Outputs**



**Digital I/O,  
Sustained 16 MB/s  
With 80 MB/s Bursts**

**USB/104<sup>®</sup> Embedded OEM Series**

- Revolutionary USB/104<sup>®</sup> Form Factor for Embedded and OEM Applications
- USB Connector Features High Retention Design
- PC/104 Module Size and Mounting Compatibility
- Extended Temperature and Custom Options Available
- Choose From a Wide Variety of Analog, Digital, Serial, and Relay I/O

**ACCES I/O Products' PC/104 size embedded USB boards for OEM data acquisition and control.**

**OEM System SPACE Flexibility with dozens of USB/104<sup>®</sup> I/O modules to choose from and extended temperature options - Explore the Possibilities!**



**USB 2.0**

**Saving Space,  
The Final Frontier**



**ACCES I/O PRODUCTS, INC.**  
The source for all your I/O needs  
To learn more about our Embedded USB/104 I/O boards visit <http://acces.io>  
or call 800 326 1849. Come visit us at  
10623 Roselle Street San Diego CA 92121



**USB**



**PC/104**



**USB/104**



**Systems**

# Lester Eastman: Materials Pioneer Leaves A Legacy Of Teaching

**M**ost people have never heard of compound semiconductors like gallium arsenide (GaAs), indium phosphide (InP), or gallium nitride (GaN). But they do rely on the smart phones these materials have enabled, as well as other vital applications like radar and satellite communications. Many of these innovations wouldn't have been possible without the work of Lester Eastman, who died on August 9, 2013, at the age of 85.

"Professor Eastman had a tremendous impact on the field of microwave electronics, particularly the area which uses compound semiconductors," said Michael Spencer, a professor of electrical and computer engineering at Cornell University and one of Eastman's former students. "First with gallium arsenide, and then later with other III-V materials such as alloys of gallium arsenide with aluminum arsenide, indium phosphide, indium gallium phosphide, and so forth."

## A MATERIALS PIONEER

Eastman was renowned for his pioneering work in compound semiconductor materials and high-speed devices for microwave and semiconductor laser applications. He began this work in 1965 at Cornell University as an associate professor, and it continued through his retirement in 2011—and even afterward, as he mentored students and colleagues from several scientific disciplines.

"One of the most important applications of gallium-arsenide materials has been in the development of low-noise amplifiers. These compound-semiconductor-based transistors operate in such a way that you can receive very, very faint signals from distant sources," Spencer said.

"As a matter of fact, one of the early science applications of these types of transistors was in the great antennas that are lis-

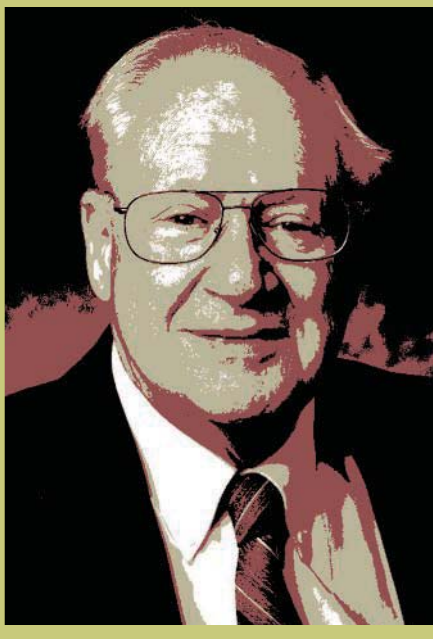

Cornell University celebrated Lester Eastman's six decades with the school with a 2008 symposium titled "Tubes to Transistors: Megahertz to Terahertz."

tening for communication from deep space. And these gallium-arsenide-based devices had the lowest noise figure of any other kind of electronic device. So one big application was low-noise, high-gain microwave amplifiers," Spencer continued.

Eastman's later work focused on gallium-nitride high-power microwave devices, which provide power to send signals across great distances. These transistors power phased-array radar systems for military applications, for instance, with other radar applications expected to use the technology in the future.

"Professor Eastman led a research team that was the pioneer or one of the pioneers in developing gallium-nitride-based technology. When we talk about gallium-nitride technology, it really is gallium nitride plus aluminum gallium nitride. It works together, and the technology that has proved so beneficial is a heterojunction technology of gallium nitride and aluminum gallium nitride," Spencer said.

Among other innovations, this team developed polarization doping. Historically, researchers would add intentional impurities to produce electrons or holes in semiconductor materials. But chemical group III nitride materials exhibit spontaneous polarization, so doping occurs as a result of electrons shifting to compensate for the fixed charge due to the polarization. Polarization doping offers many semiconductor performance advantages that Eastman's team explored, publishing many significant papers on the topic. Many military and commercial applications have benefitted from their work.

"The most recent innovation that people have tried to exploit this material system for is power," Spencer said. "When I talk about power, I don't mean microwave power now. I mean normal, low-frequency power converters like you have in a power supply. And people have invested a lot of money in pursuing the





Cornell University celebrated Lester Eastman's six decades with the school with a 2008 symposium titled "Tubes to Transistors: Megahertz to Terahertz."

idea that a gallium-nitride system might be an interesting system for making low-frequency, high-power converters. That is under investigation. But in the meantime, all of the microwave applications are actually in production."

#### A BIG MAN ON CAMPUS

Perhaps Eastman's tenure at Cornell is as remarkable as his innovations. He earned his BSEE at the upstate New York campus in 1953, followed by his MS in 1955 and his doctorate in 1957, all in electrical and computer engineering. He was then named an assistant professor in 1957, an associate professor in 1960, a full professor in 1966, and the John L. Given Professor in Engineering in 1985. In 2011, he was named a Professor Emeritus. No matter the title, though, he always displayed great enthusiasm for the work.

"Most of us who had Les remember him best as a research advisor. He always had a really great grasp of the overall picture, and he could determine where the key innovations or challenges were and where to focus everybody's energy and how to make the research group work as a team. I think that's where his talent was," Spencer said.

"You could always come to his office at 8 o'clock in the morning, and he would give you a mini-lecture on the latest developments in compound semiconductors. It was almost like he was talking from a script. It was just a wonderful thing."

In 1977, Eastman was a founding member of the National Research and Resource Sub Micron Facility, now known as the Cornell Nanofabrication Facility. Also in 1977, he initiated the Joint Services Electronics Program at Cornell and directed it for 10 years. He brought this experience in founding and leading research programs to Europe, which he visited 111 times during his career. For instance, he helped Sweden establish its \$90 million nanoscale facility, and he helped Germany establish one as well.

Yet Eastman always returned home to Cornell, where he co-authored more than 600 publications. He also tallied a campus record of 125 PhD students under his direct supervision, in addition to 75 post-docs. His former students include Donald MacLean Kerr Jr., former director of Los Alamos National Laboratory and now principal deputy director of National Intelligence, David Welch, cofounder of Infinera Inc., and 27 professors in the U.S. and abroad.

"I think it was just the kind of person he was. He loved his work, and he loved working with people. And he always seemed to bring out the best in people," Spencer said. "He always did best in one-on-one situations."

Eastman earned many awards and honors during his career. Cornell, for example, honored him with a symposium entitled "Tubes to Transistors: Megahertz to Terahertz" in June 2008 to celebrate his 60th year at the university. Also, the IEEE sponsors the biennial Lester Eastman Conference on High Performance Devices. The next event is scheduled for August 5-7, 2014, at Cornell University.

#### ENGINEER AS ENTREPRENEUR

Eastman was a U.S. Navy veteran, serving as radar specialist on the aircraft carrier U.S.S. Coral Sea from 1946 to 1948. Spencer says that this experience "absolutely informed" Eastman's research later, especially as he launched Cayuga Associates, which produced impact ionization avalanche travel time (IMPATT) and Gunn oscillators and then early gallium-arsenide FETs with micron-size structures. An earlier company he founded served the military as well.

"The first one actually made a product called Gunn diodes. And this company existed in the late '60s, early '70s, during the time of the Vietnam War," Spencer said. "And these Gunn diodes were gallium-arsenide devices that emitted high-energy microwave radiation when you applied a battery voltage to them. So these devices, which his company manufactured, were used as distress beacons for downed pilots in Vietnam."

Eastman also consulted for several companies and the MIT Lincoln Laboratories in the United States and for three companies in Europe. He served on the Department of Defense's Advisory Group on Electron Devices for six years and on the Senior Advisory Board of the Fraunhofer Institute of Applied Physics in Germany for another six years. And, never straying too far from academics, he was the external examiner of several PhDs in Europe.

"Professor Eastman, like many others, recognized that science is international. He spent his sabbatical in Sweden and developed a lot of connections there, and of his 125 students, a huge fraction of them are international students. He was especially proud of the fact that he had 125 students, and he would always talk about their accomplishments. That was the source of the greatest pride for him," Spencer said. "It was a privilege to have known and worked with him." 

# Kernighan, Ritchie, And Thompson: The Fathers Of C

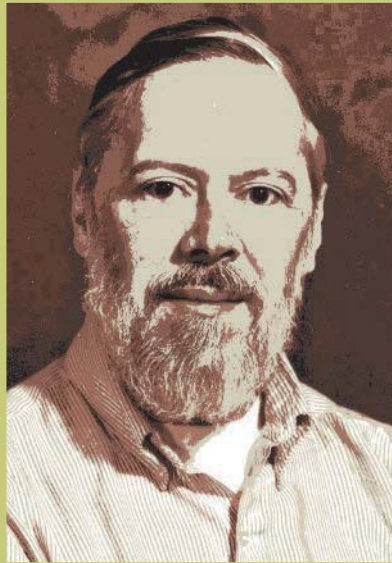

Ken Thompson (left) developed the C programming language with Dennis Ritchie (center) at the Bell Labs Computing Sciences Research Center. Thompson also wrote the first version of UNIX using C at Bell Labs. Ritchie was a key developer for UNIX and worked on the Plan 9 operating system and environment as well. Brian Kernighan (right) co-authored *The C Programming Language* with Ritchie.

**B**ell Labs was home to many inventions, but the C programming language developed there had one of the biggest impacts. Many people have worked on C to make it what it is today, the most used programming language around. Three stand out, though: Ken Thompson and Dennis Ritchie, who created it, and Brian Kenighan, who authored *The C Programming Language* with Ritchie

Ritchie and Thompson both worked with BCPL (Basic Combined Programming Language), which was used on Multics. It was the basis for the B language developed by Thompson for UNIX on the 18-bit PDP-7 from the Digital Equipment Corporation (DEC). The PDP-7 had a 1.75- $\mu$ s memory cycle time, and an add instruction took 4  $\mu$ s to execute. The typical system had only 4 kwords.

Ritchie modified B, which eventually became the C programming language. One major difference was C's handling of pointers. C also had a character type. It was designed to be adapted to new hardware like the 16-bit DEC PDP-11. Ritchie and Thompson received the ACM Turing Award in 1983 for their work on C as well as UNIX. Thompson wrote the first version of UNIX in assembler, followed by many iterations written in C.

## KENNETH THOMPSON

"Our collaboration has been a thing of beauty. In the 10 years that we have worked together, I can recall only one case of miscoordination of work," Thompson said about Ritchie in his ACM Turing Award Lecture: Reflections on Trusting Trust. "On that occasion, I discovered that we both had written the same 20-line assembly language program. I compared the sources and was astounded to find that they matched character for character. The result of our work together has been far greater than the work that we each contributed."

Also in his Turing Award lecture, he described how he had incorporated a backdoor security hole in the original UNIX C compiler. To do this, the C compiler recognized when it was recompiling itself and the UNIX login program. When it recompiled itself, it modified the compiler so the compiler backdoor was included. When it recompiled the UNIX login program, the login program would allow Thompson to always be able to log in using a fixed set of credentials.

The initial C compiler source code included the hack. The source code for subsequent compilers had it removed, though. The binary would include the backdoor when compiled with

a compiler that includes the backdoor code. After discussing the backdoor, Thompson stated, "The moral is obvious. You can't trust code that you did not totally create yourself."

Thompson has worked on a variety of projects, including the QED and ed editors. This included his construction algorithm for converting regular expression into nondeterministic finite automaton. The algorithm improves the performance of expression pattern matching. He also developed the widely used character encoding scheme, UTF-8, with Rob Pike and helped create the world champion Belle chess computer hardware and software with Joseph Condon.

Thompson works for Google as a Distinguished Engineer, where he helped design the Go programming language. He received a BS and MS in electrical engineering and computer science from the University of California, Berkeley.

#### DENNIS RITCHIE

Born in 1941, Ritchie started working at Bell Labs in 1967 after graduating from Harvard University with degrees in physics and applied mathematics. He did part-time graduate work on the Massachusetts Institute of Technology's Project MAC using the Multics system. While at Bell Labs, he earned his PhD, also from Harvard.

Ritchie met and worked with Thompson and Kernighan at Bell Labs, where he was a key developer for C and UNIX and wrote *The C Programming Language* with Kernighan. He also was responsible for many Unix ports to new hardware. Additionally, Ritchie worked with Thompson, Rob Pike, Dave Presotto, and Phil Winterbottom at Bell Labs on the Plan 9 operating system and programming environment.

Plan 9 was designed to be a distributed, grid computing platform. It evolved into the Inferno operating system, which is now available from Vita Nuova (see "Inferno Operating System Burns Its Way Into Embedded Systems" at [electronicedesign.com](http://electronicedesign.com)). Inferno ran on a virtual

machine called Dis using a communication protocol called Styx. Applications were written in Limbo.

Dennis Ritchie died in 2011 a week after Steve Jobs passed away.

#### BRIAN KERNIGHAN

Kernighan received a bachelor's degree in engineering physics from the University of Toronto and a PhD in computer science from Princeton University. He wrote a number of UNIX applications in C such as cron and ditroff, but he did not work on the C language development. He also wrote a tutorial for the B language developed by Thompson (see "Interview: Brian Kernighan Talks About Computers, Programming, And Writing" at [electronicedesign.com](http://electronicedesign.com)). B turned into NB (New B) and then into C, so he wrote the first draft of *The C Programming Language*. Ritchie wrote the system programming sections as well as Appendix A.

Kernighan went on to many other programming projects like AWK with Al Aho and Peter Weinberger and EQN with Lorinda Cherry. He developed the Ratfor FORTRAN preprocessor, which essentially took a C-style program flow and generated FORTRAN source code. Ratfor was written up as part of the "Software Tools" series from Prentice Hall, where he was the software editor.

Also, Kernighan came up with the original name for UNIX, Unics (Uniplexed Information and Computing Service). It was a variation on Multics (Multiplexed Information and Computing Service), an early mainframe, time-sharing operating system used at Bell Labs.

Currently, Kernighan is a professor with the Computer Science Department of Princeton University, where he is the undergraduate department representative as well. He has continued to write with other software notables like P.J. Plauger for *The Elements of Programming Style*. His latest book, *D is for Digital*, is based on his Princeton course, "Computers in Our World." It is designed to describe how computing works for a non-technical audience. 

## Board level heatsinks

- effective heat dissipation around the PCB
- made as a sheet metal part or heatsink
- made of aluminium- or copper material
- solderable surface coatings
- for horizontal and vertical mounting
- special designs according to customer specifications

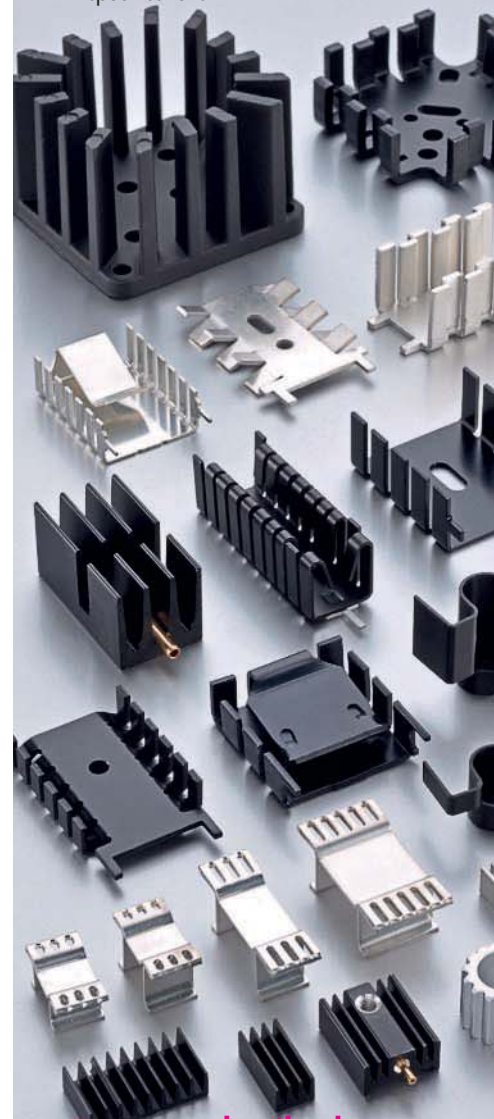

For more details please  
check our website:  
[www.fischerelektronik.de](http://www.fischerelektronik.de)

Fischer Elektronik GmbH & Co. KG

Nottebohmstraße 28  
D-58511 Lüdenscheid  
Phone +49 (0) 23 51 43 5-0  
Fax +49 (0) 23 51 4 57 54  
E-mail [info@fischerelektronik.de](mailto:info@fischerelektronik.de)



# Shuji Nakamura: Blue Skies Await For Blue LED Illumination

**S**huji Nakamura enabled an entire industry based on high-brightness LEDs replacing incandescent, gas-discharge, and fluorescent lighting in vehicles, homes, businesses, and outdoors. He did it by developing a practical way to manufacture efficient blue and ultra-violet LEDs, which are the basis for “white” LEDs.

The challenge for LED lighting is that the wavelength of the light emitted is determined by the band gap of the semiconductor material from which the diode is fabricated. Red and green LEDs were fairly easy. But blue, which could be used with “yellow” phosphors to produce a mix of photons that would appear white, was another story.

Theoretically, some compound semiconductor materials from groups III and V of the old atomic table might be satisfactory. However, the process technologies needed to create them were yet to be uncovered. Building on decades of prior work, Nakamura unlocked the secret. (In today’s atomic table, groups III and V are now designated groups 13 and 15.)

Nakamura also is a hero to many working engineers for his legal actions to collect his fair share of profits that accrued to his employer from his invention. A Japanese court deemed an initial single royalty payment of less than \$200 in yen would more fairly have been on the order of \$180 million. Ultimately, the parties settled on the equivalent of \$8.1 million.<sup>1</sup>

The case was closely watched in Japan as a test of long-held notions that employees should sacrifice for their companies and that there was something unseemly about individual workers seeking a bigger cut of profits than their coworkers.

Traditionally, corporate engineers and scientists in Japan were treated just like less skilled employees. Unlike American companies, Japanese companies seldom signed contracts with their



**Shuji Nakamura built on the work of earlier researchers to develop a practical semiconductor process for fabricating blue LEDs, which are the basis for high-brightness “white” LEDs.**

researchers specifying how profits from their inventions will be shared.

## **BUILDING ON EARLIER WORK**

Nakamura’s research didn’t take place in a vacuum. Previously, the hunt for an economically sustainable way to manufacture blue LEDs on silicon carbide (SiC), gallium phosphate (GaP), and gallium nitride (GaN) had been long and frustrating, with very disappointing electrical-to-optical conversion efficiencies.<sup>2</sup>

In the late 1960s and early 1970s, RCA came very close to developing viable blue LEDs, thanks to the research of James Tietjen, Jacques Pankove, Ed Miller, David Stevenson, and Maruska, working collaboratively at RCA Laboratories and Stanford University. When RCA went out of business in 1986, though, that research virtually stopped.

Meanwhile, in Japan in the late 1960s, Isamu Akasaki had begun working on GaN-based blue LEDs at the Matsushita Research Institute. Then, in 1989 at Nagoya University, Akasaki developed the first GaN p-n junction blue/UV LED. The p-n junction was a major breakthrough.

## **AS NAKAMURA TELLS IT**

In a speech at the Takeda Award forum in 2002, Nakamura described his evolution from a young graduate engineer with a specialty in electronics to a semiconductor process researcher.<sup>3</sup> In his first job after graduation at Nichia Corp., he researched GaP crystal growth heating compounds in quartz tubes. It was not ideal.

“I spent almost every day welding quartz tubes, inserting raw materials and heating them in the furnace, where they would explode with a loud bang,” he said. “I was just a quartz-welding technician at that time! I couldn’t imagine my present situation. At that time I thought that my whole life was over.”



While he was at Nichia, Nakamura developed a process for making a diode with a band-gap voltage that would enable junctions to emit photons with a “blue” wavelength when they were forward-biased. That process technology enabled a whole range of products from consumer home and automobile lighting to more efficient outdoor lighting and to controls and drivers for all those applications.

He then investigated gallium arsenide (GaAs), which can be produced using a similar method. At this time, GaAs was used for red and infrared LEDs. After three years of that, he worked on the epitaxial growth of gallium aluminum arsenide (GaAlAs) and developed practical infrared and red LEDs.

Speaking perfectly frankly, he said, “Unfortunately, the devices which were developed did not sell well, and so the company spoke badly of me. I was seen as a freeloader.”

Nevertheless, while he had been developing LEDs during those 10 years, he had always wanted to try and develop a blue LED. But the company feared that it lacked the resources to pursue that goal successfully.

“After completing my tenth year, I was urged to quit the company and so I blew a fuse. I decided to propose the development of the blue LED, which I wanted to develop, and if it was impossible, then I would resign the company.”

Nakamura was surprised when company founder Nobuo Ogawa approved.

“I stuck my neck out and said, ‘We need a budget of several hundred million yen in order to complete the development of a blue LED.’ He replied ‘okay.’ Then, I asked him to permit me to study abroad at Florida University for one year. Again, ‘okay.’ Everything was okay in just 5 seconds. It was that easy,” he said.

“I went abroad to Florida University where I wanted to study MOCVD (metal organic chemical vapor deposition), and on my return I started the research of blue LEDs,” he said.

Nakamura noted that the price of the MOCVD equipment was 2 hundred million yen, which made him feel pressure to get some results. “So I began to modify the equipment in my own way. I continued making these modifications every day for one-and-a-half years,” he said.

In the summer of 1990, he invented Two-Flow MOCVD. “When I used this to grow GaN crystals, I could get results

superior to the data of what had been the best in the world up until then. I was absolutely delighted,” he said.

Using the modified equipment, he made crystals one after the other. Over two to three months, he produced several “first in the world” and “best in the world” results, such as indium gallium nitride (InGaN).

He also experimented with modifying the structure of the LED devices. “I could get an extremely bright light,” he said. He made other breakthroughs, including obtaining p-type GaN. “I had succeeded in getting p-type GaN simply by heat treatment,” he said. “Once again it was the quality of the equipment that had allowed me to produce such high quality p-type GaN.”

This was in the summer of 1990. That work resulted in a blue LED that emitted strong light in a laser diode.

### SECRECY AND PATENTS

Ironically, considering the patent issues that would later evolve, this activity almost did not result in patents.

“The company prohibited publishing articles and speaking at academic conferences. Even applications for patent types that were subject to public disclosure were prohibited. All patent applications were limited to ‘know-how’ applications (not made public by the patent office),” Nakamura said.

Yet Nakamura had felt humiliated when he first arrived at the university in Florida. He felt the other grad students did not respect him because he had not published as they had. He decided he was not going to put up with that any more.

“After I succeeded with Two-Flow MOCVD, I submitted the articles in secret. Before submitting the articles, I made patent applications as a way of covering my back once the articles were publicized,” he said.

“I succeeded in commercializing the blue LED in 1993. This device emitted bright light with intensity more than 100 times brighter than previous devices. I also developed and announced the commercialization of green LEDs in 1995. I achieved the first laser oscillation in late 1995 and succeeded in the commercialization of the blue laser in about 1999. In the meantime I made several hundred patent applications and about 50 important patents were granted that produced profits for the company,” he said.

In 1999, after he was moved into management, a job that he hated and called “stamping papers,” Nakamura left joined the faculty at the University of California, Santa Barbara. Later, he founded Soraa, the only company now making commercial GaN-on-GaN LED lighting products. 

### REFERENCES

1. “Japanese Company to Pay Ex-Employee \$8.1 Million for Invention,” Todd Zaun, The New York Times, January 12, 2005, [www.nytimes.com/2005/01/12/business/worldbusiness/12light.html?oref=login&r=0](http://www.nytimes.com/2005/01/12/business/worldbusiness/12light.html?oref=login&r=0)
2. Herbert Maruska, “A Brief History of GaN Blue Light-Emitting Diodes,” [www.sslighting.net/news/features/maruska\\_blue\\_led\\_history.pdf](http://www.sslighting.net/news/features/maruska_blue_led_history.pdf)
3. The Takeda Award Forum 2002, Shuji Nakamura, [www.takeda-foundation.jp/en/award/takeda/2002/forum/03a.html](http://www.takeda-foundation.jp/en/award/takeda/2002/forum/03a.html)

# John Napier: Logarithm Inventor Put Religion First

There was a time not so long ago when calculators weren't standard equipment for computations. The  $\log()$  button did not exist, and some math had to be done by hand. John Napier and his logarithm simplified these tedious calculations. In 1614, he published *Mirifici logarithmorum canonicis descriptio*, which translates to *A Description of the Wonderful Table of Logarithms*. There are strikingly few books written about Napier, but from those that we have, we know that the Napiers of Merchiston were a noble, well-respected family and that John Napier did not have a day job, allowing him more time to focus on his studies.

Napier is best known for logarithms and his "bones." Although these two terms are often clumped together, they really have nothing to do with each other. While Napier's bones are used for simple multiplication and division problems (made simpler by addition and subtraction), they could not be used to calculate large problems like logarithms can. After working on logarithms for 20 years, he published his book and has been known as their inventor ever since. However, there was quite an unknown competition during this time period that is rarely discussed. Not only is Napier the creator of a tool that has changed the life of engineers forever, he also had the cunning to ensure his idea was used.

## RACE TO THE FINISH

John Napier was not alone in trying to find an easier way to accurately make calculations. During his time, astronomers were constantly making mistakes because of the large computations they had to perform. Joost Bürgi was one of these competitors. But Napier was smart, and he knew that it was important to get his work recognized. Publishing in English, printing his tables instead of handwriting them, and including a "user man-

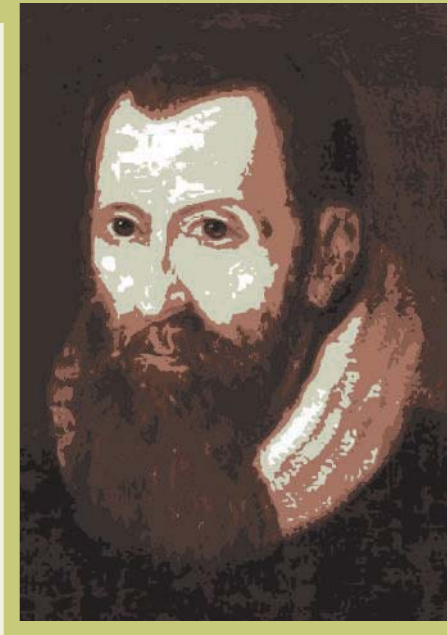

While John Napier of Merchiston is known for inventing the logarithm, mathematics were only a hobby while he campaigned against Queen Mary for the Protestant cause.

ual" with each book all made it easier to spread his ideas. Napier also was not afraid to take criticism, and he discussed how to improve his original system with Henry Briggs.

"Napier started his tables by saying [...] that the beginning of the logarithmic values was 0 and it actually needed to be 1 to make the rest of the tables fall in line. So Briggs already had this idea, but Napier knew this was a problem," said Dr. Kathleen Clark, associate professor at the School of Teacher Education at Florida State University.

Napier was so dedicated to his visits with Briggs that he actually died after one of his journeys. Bürgi, on the other hand, had a different set of responsibilities.

"Bürgi was employed by the royal court, the Habsburgs of Czechoslovakia, so he basically just went between his home country and Prague," Clark

said. Although Bürgi had similar ideas and was potentially working on them before Napier, he was not published until Napier's text had been out for six years—thus the term logarithm had already been coined. So, would Bürgi's method have been used if he had been of the same social standing as Napier?

"It is possible, although there are several other features of Napier's work that made it popular; that it was immediately useful for the computation of sines, for instance, proved to be a huge advantage," said Dr. Clemency Montelle, senior lecturer in the Department of Mathematics and Statistics at University of Canterbury. "Bürgi was at a royal court as well and had a few powerful friends."

Although Napier had a social advantage, Bürgi seems to have had many connections as well. Questions about whether or not Bürgi's work would have been used more had he had this advantage, then, seem irrelevant. Napier's work was the best in the long run.

## LOGICAL WIT

It wasn't all book smarts with Napier. He was also able to outwit many people. Mark Napier, a decedent of his, wrote in his *Memoirs of John Napier of Merchiston* about how John dealt with thieving servants: "Having missed some property, and suspecting his servants, he ordered them one by one into a dark room, where his favorite [rooster] was confined, and declared that the cock would crow when the guilty one stroked his back, as each was required to do. The cock remained silent during all the ceremony; but the hands of one of the servants were found to be entirely free from the soot with which the feathers of the mysterious bird had been anointed."

Napier was a successful farmer as well, causing some to say he dabbled in alchemy.

"Evidently Napier spent a good deal of time going around dressed in a nightgown and cap. This led people to say that he was dressed as a warlock. Some biographies include the claim that Napier made a deal with the devil," said Michael J. Caulfield, professor of mathematics at Gannon University.

However, Napier did not need the devil's help to make sure his crops were cared for. After warning a neighbor about his pigeons eating his crops, Napier threatened to catch the birds and keep them. The neighbor, not believing such a thing was possible, told Napier that if he could catch the birds then he could have them. The next morning the neighbor found Napier putting the birds into a sack. Napier had fed the birds brandy soaked peas, making them drunk and easy to obtain! This is just another example of one of the unorthodox ways Napier handled problematic situations.

## FIRST AND FOREMOST, A DEVOUT PROTESTANT

John Napier's commitment to the Protestant church may be overlooked due to his notable contributions in mathematics. Yet he considered his work regarding the church, *A Plaine Discovery of the Whole Revelation of St.*

*John*, to be his greatest achievement. He believed that if he was ever going to be known for something, this would be it.

Napier predicted that the world would end between 1688 and 1700, due to the belief that Pope Clement VIII was the Anti-Christ. At this time in the United Kingdom, the Catholic church—headed by Queen Mary—was trying to regain power

# Custom Inductor Price-Performance 101



When you need custom inductors for EMI/RFI filtering and circuit protection, Datatronic Distribution, Inc., has the answers. Our custom magnetics white paper explains how to balance performance with cost for true value. Ask us about:

- > Shielded Designs
- > Unshielded Designs
- > Surface Mount
- > Through-Hole
- > High-Temperature
- > Flat Wire

Our inductors meet the industry's most demanding performance, environmental and quality standards:

ISO9001 and ISO9002

TS16949:2002

UL Insulation Systems to 200°C

BABT  
CSA  
VDE



### The Magnetics Design Expert

Download our new Short Form Guide, Custom MagNETics Web Design Tool and White Papers at [datatronics.com](http://datatronics.com) or call 1-951-928-7700.

 **DATATRONICS**

over devout Protestants. Napier was very active in the movement against the queen. In addition to his writing, he set up artillery equipment that was meant to help the cause. One of these pieces includes the first modern-day tank, described as a vehicle covered in metal plates that men seated inside it drove. One of these inventions also included a mirror for burning enemy ships at any distance.

A driving force in the crusader's quest to protect Scotland and the Protestant religion may have been his father's imprisonment by Queen Mary in 1571 after Napier returned home from studying abroad.

"From the moment his mind began to work he aspired to be a Protestant champion and applied his whole energies to that sacred cause," Mark Napier wrote in his *Memoirs*. Although

there is little known about John Napier's life as a religious man, his mathematical studies were only a hobby. He spent more of his time contributing to the controversial religious wars and tending to this castle.

### SURVIVING BONES

Napier's bones are his second most famous invention—behind logarithms, of course. But even though they are usually grouped together, Napier's bones and logarithms have nothing to do with one another.

"Napier's bones was a device that would actually use lots of intermediate addition, instead of one large addition," said Clark. They really are not suitable for trigonometry or any multiplication greater than 9.

While the bones are no longer considered useful, they were quite an innovation for the times—like a basic calculator. Napier's bones are also known as Napier's rods, which is a more accurate description. Before Napier's tables could be mass produced and printed, his bones were physical rods, with the highest quality rods made out of ivory (which is why they are now called his bones).

The significance of his logarithms cannot be argued. Although the calculator also takes care of this function now, the logarithm greatly changed the lives of astronomers in Napier's time.

"The logarithms developed by Napier allowed Johannes Kepler to more easily see the patterns hidden in Tycho Brahe's data and thus to formulate Kepler's three laws of planetary motion," said Caulfield. "Later, Pierre-Simon Laplace, who lived in the late eighteenth and early nineteenth centuries, said that Napier 'by shortening the labors doubled the life of the astronomer.'" 



# FULL METAL VALUE

Our Challenger line of rack enclosures is a value leader, built in the U.S. to the same quality standards as our heavy-duty enclosures. It can more than handle the majority of commercial applications and be customized to suit special needs.

- All welded construction minimizes twist, sway or deflection
- Universal side panels can either be securely fastened from inside the cabinet to prevent tampering or easily lifted off externally
- Choose flush mount doors with lift-off hinges or face-mount doors - all with positive latching hardware as a standard feature
- Vertical racks, sloped-front consoles (15 degree), double-slope consoles (30 and 45 degree), low-profile frames and bench-top racks

An exceptionally wide range of accessories are available. Choose from standard colors or we'll match your favorite. Available for quick delivery. **Learn more now at [EquiptoElec.com](http://EquiptoElec.com) or call us.**



**EQUIPTO**  
Electronics Corp.  
Made with pride in the USA

800-204-7225 Ext. 9 • 630-897-4691  
email: [sales@equiptoelec.com](mailto:sales@equiptoelec.com)  
[www.equiptoelec.com](http://www.equiptoelec.com) • ISO 9001:2008 • RoHS Compliant

Frame is 14 gauge cold rolled steel.





# John Renshaw Carson: Modulation's Earliest Innovator

**T**his year, we recognize John R. Carson for two major contributions to communications technology: the invention of single-sideband (SSB) modulation and his rule for estimating frequency modulation (FM) bandwidth. We still use these cornerstones of communications theory today.

## THE MAN

While we remember innovations, we often know less about those who developed them. More commonly known as J.R. Carson, John Renshaw Carson was born in Pittsburgh on June 28, 1886.

Carson and his twin brother, Joseph Robb Carson, both attended Princeton University and graduated from there in 1907 with bachelor of science degrees. For interested researchers, Princeton's Mudd Manuscript Library has a collection of letters exchanged between John and Joseph, mainly about the state of student life at the university in 1903 and 1904.

John went to the Massachusetts Institute of Technology in 1907 and 1908 but returned to Princeton where he earned a degree in electrical engineering in 1909 and a master's degree in electrical engineering in 1912. Carson taught electrical engineering at Princeton for a while and left the university in 1914 to join AT&T.

Carson's serious career in engineering began at AT&T where he worked as both an electrical engineer and a mathematician. Very early in his work, he invented SSB modulation. He filed for the patent entitled "Method and Means for Signaling with High Frequency Waves" on December 1, 1915. After significant litigation, he was granted patent #1449382 on March 27, 1923. SSB has had a significant impact on telephony as well as radio communication.

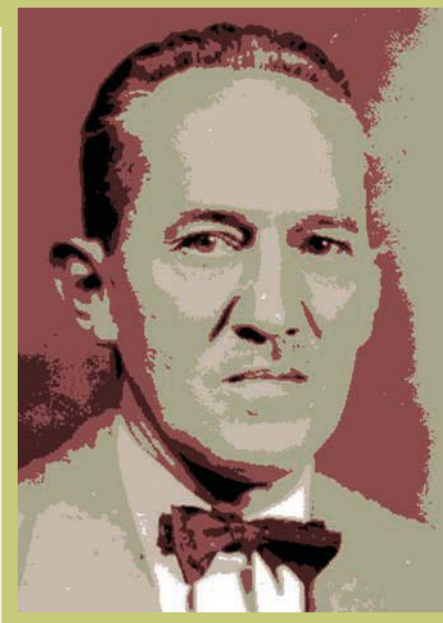

**John Renshaw Carson invented single-sideband modulation and developed the Carson rule, which defines the approximate bandwidth requirements of communications system components for a carrier signal that is frequency modulated by a continuous or broad spectrum of frequencies rather than a single frequency.**

The young engineer performed a significant amount of mathematical analysis of communications methods. He analyzed frequency modulation and debated Edwin Armstrong, the inventor of FM, regarding FM's noise benefits. In his paper "Notes on the Theory of Modulation," published in February 1922 in the Proceedings of the Institute of Radio Engineers (now IEEE), he put forth his now well-known Carson's rule about FM bandwidth.

Carson moved to Bell Telephone Laboratories in 1925 and worked there until his death in 1940. In 1926 McGraw Hill published his book *Electrical Circuit Theory and Operational Calculus*. The book is an organized collection of material gleaned from the many technical papers he wrote for the Bell Labs technical journals. You can still get a copy of it from Amazon. In 1937, he received an honorary doctor of science degree from Brooklyn Polytechnic Institute in recognition for his

many contributions to telephony and radio technology.

Carson never got to see all of the real benefits of his work. While he did see the use of SSB in telephone networks, he did not witness the surge in SSB usage in radio after World War II.

## SINGLE-SIDEBAND MODULATION

SSB is a special form of amplitude modulation (AM) in which the carrier is suppressed and one sideband is removed. The benefit is the significant reduction in bandwidth needed to transmit information using modulation compatible with the wire or radio channel (*see the figure*).

Carson saw his invention used to implement frequency division multiplexing (FDM) techniques in the telephone network. FDM was used to package multiple conversations for long-distance calls over a single line. Each call modulated a subcarrier

# Keil MDK-ARM

MDK-ARM™ is the complete development environment for ARM® Cortex™-M series microcontrollers.

[www.keil.com/mdk](http://www.keil.com/mdk)



## ARM DS-5

DS-5™ Professional is a full featured development solution for all ARM Powered® platforms.

[www.arm.com/ds5](http://www.arm.com/ds5)



# ARM®

+1 800 348 8051

© ARM Ltd. AD364 | 01.13

## Hall of Fame

on a different frequency, and all of the carriers were summed and transmitted on a common line.

The problem was that AM consumed considerable bandwidth because it produced two sidebands around the carrier that occupied a bandwidth twice the highest frequency of the audio to be transmitted.

Because the telephone lines, both twisted pair and coax, had limited bandwidth especially over long distances, few calls could be handled. But SSB cut the bandwidth in half, doubling the call capacity. With the telephone system limiting voice spectrum to the 300- to 3400-Hz range, a single call could be transmitted in 4 kHz of bandwidth.

The multiplex system started with 12 calls each modulating carriers spaced 4 kHz in the 60-kHz to 108-kHz range. The modulators were diode ring balanced modulators that suppress the carrier, leaving two sidebands. The lower sideband (LSB) is selected with a sharp LC or crystal filter. The 12 subcarriers were then combined in a linear mixer to form what was known as a basic group.

Up to five basic groups could be further multiplexed on to higher-frequency subcarriers in the 312-kHz to 552-kHz range spaced 48 kHz apart. The upper sidebands (USBs) were used to create a super-group. Then, 10 super-groups could be combined by modulating subcarriers in the 600-kHz to 2540-kHz range to form a master group of 600 calls. Six master groups also could be combined to form a 3600-channel jumbo group. Combining three jumbo groups produced a maximum of 10,600 calls on a single line.

Demultiplexing was accomplished with selective filters to recover the sidebands and balanced modulators to reproduce the original audio. Pilot subcarriers were also transmitted to aid in the demodulation process.

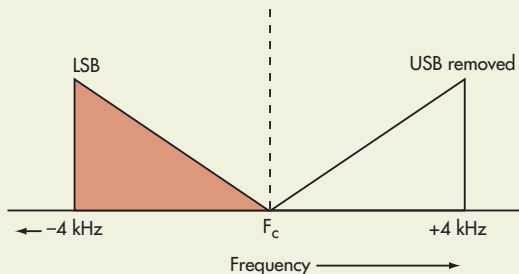

Single-sideband (SSB) modulation suppresses the carrier  $F_c$  (dashed line) and eliminates one sideband. Here, the upper sideband (USB) is filtered out, leaving only the highlighted lower sideband to be transmitted.

This SSB form of analog multiplexing first came into use in the 1930s and was used extensively throughout the Bell telephone system until the 1970s when digital multiplexing (T1 and T3 lines, etc.) came into use.

The first experiments involving SSB's use in radio occurred during World War I. Commercial experimentation continued throughout the 1920s and 1930s. After World War II, SSB was adopted by the amateur radio community, which significantly contributed to the practical development of the technology.

The Air Force adopted SSB in the 1950s for long-range bomber communications, but it is no longer used. Today, SSB is one of the dominant modes of amateur radio communications along with FM and CW. SSB is also used in citizen's band (CB) radios and long-range marine radios.

Another application of SSB is in TV broadcasting. The original U.S. National Television Standards Committee (NTSC) TV standard used vestigial sideband (VSB) modulation, which is a modified form of SSB where one sideband and only a part of the other sideband is suppressed. The TV signal then could fit into the 6-MHz wide channels assigned by the Federal Communications Commission.

Today, digital TV uses VSB again to ensure the TV signal occupies no more than 6 MHz. The digital modulation is 8VSB, where the digital signal is transmitted in eight levels to provide the data rate required for high-definition TV.

## 80V Synchronous 4-Switch Buck-Boost Controller Delivers Hundreds of Watts with 99% Efficiency – Design Note 521

Keith Szolusha and Tage Bjorklund

### Introduction

A DC/DC converter's efficiency and component temperature are important considerations in high power applications where high current could overheat the catch diode used in an asynchronous buck or boost topology. Replacing the catch diode with a synchronous switch can significantly improve overall converter efficiency and eliminate much of the heat that would be otherwise generated in the nonsynchronous catch diode.

The advantages offered by a synchronous buck or boost topology can also be applied to a buck-boost topology, where the converter's output voltage falls within its input range. In this case, a synchronous 4-switch buck-boost converter using a single inductor offers the same advantages as a 2-switch synchronous buck or boost.

The **LT<sup>®</sup>8705** is a synchronous 4-switch buck-boost controller IC that can deliver hundreds of watts with high efficiency for constant voltage or constant current applications from wide-ranging inputs (up to 80V). It uses a robust synchronous switch topology and adds the versatility of four servo loops (voltage and current at input and output), making it possible to design high power battery chargers and solar panel converters with minimum component count. These are only two examples of the many high power, high current telecom, automotive and industrial solutions the LT8705 can produce.

LT, LT, LTC, LTM, Linear Technology and the Linear logo are registered trademarks of Linear Technology Corporation. All other trademarks are the property of their respective owners.

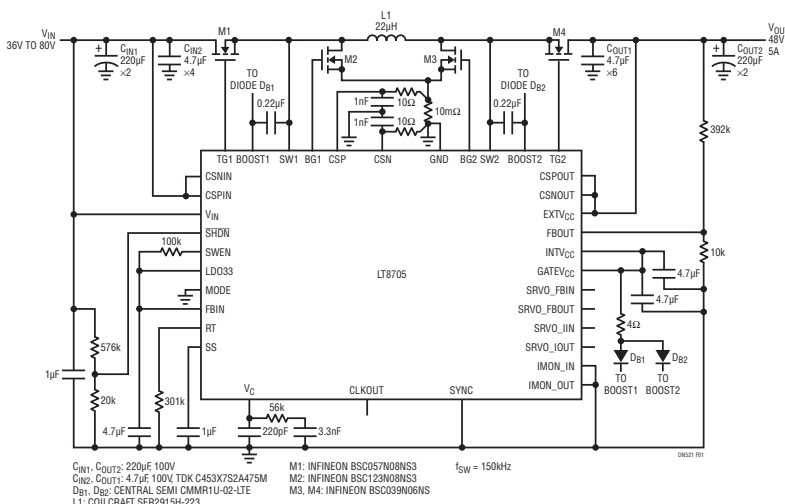

**Figure 1. LT8705 240W, 48V, 5A Buck-Boost Converter for Telecom Voltage Stabilization**

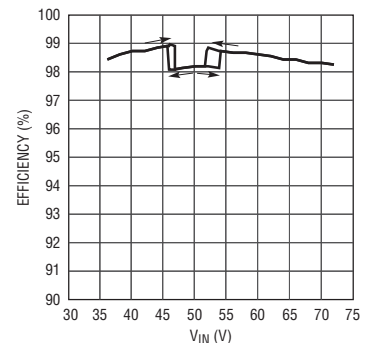

**Figure 2. The Efficiency of the LT8705, 48V Converter Is as High as 99%**

## 240W 48V 5A Telecom Power Supply

In telecom applications the input voltage has a wide (36V to 72V) range. Power converters that deliver a stabilized 48V DC voltage to the loads are commonly used. The **LT8705** can easily handle hundreds of watts at 48V output voltage, at efficiency as high as 99%. Figure 1 shows one example with 5A (240W) output.

## 500W Charger for 12S LiFePO4 battery

Figure 3 shows a circuit for charging a lithium iron phosphate battery from a 48V ( $\pm 10\%$ ) input voltage. The battery has 12 cells in series, so the maximum charge voltage is 44V. This means that the circuit will operate in step-down (buck) mode most of the time, but at lowest input voltage it must operate in buck-boost mode.

At a 48V input voltage the circuit has an efficiency of 99% at full load. The efficiency is high because only the input stage (M1, M2) is switching at high duty cycle and M4 is on continuously. The efficiency drops slightly if the input voltage is reduced to the minimum input voltage (43.2V), as the LT8705 circuit then must operate in buck-boost mode when all MOSFETs are switching.

An external microcontroller can be used for the charge algorithm, and for controlling current and voltage from the LT8705 power converter.

## Four Servo Loops and Wide Voltage Range

The LT8705's 2.8V to 80V input and its 1.3V to 80V output ranges, combined with its four servo loops, allow it to easily solve a number of traditionally complex problems. The four servo loops can be used to control input and output voltages and currents. For instance, the input voltage and current can be regulated along with the output voltage and current for maximum power point solar panel applications.

The IC outputs a flag for each servo loop, indicating which is in control at any given time. This is particularly useful information for microcontrollers in battery chargers and solar panel converters.

## Conclusion

The LT8705 is an 80V synchronous 4-switch buck-boost controller, that can provide hundreds of watts at up to 99% efficiency with a single inductor. Its four servo-loops allow it to regulate current and/or voltage for both the input and output.

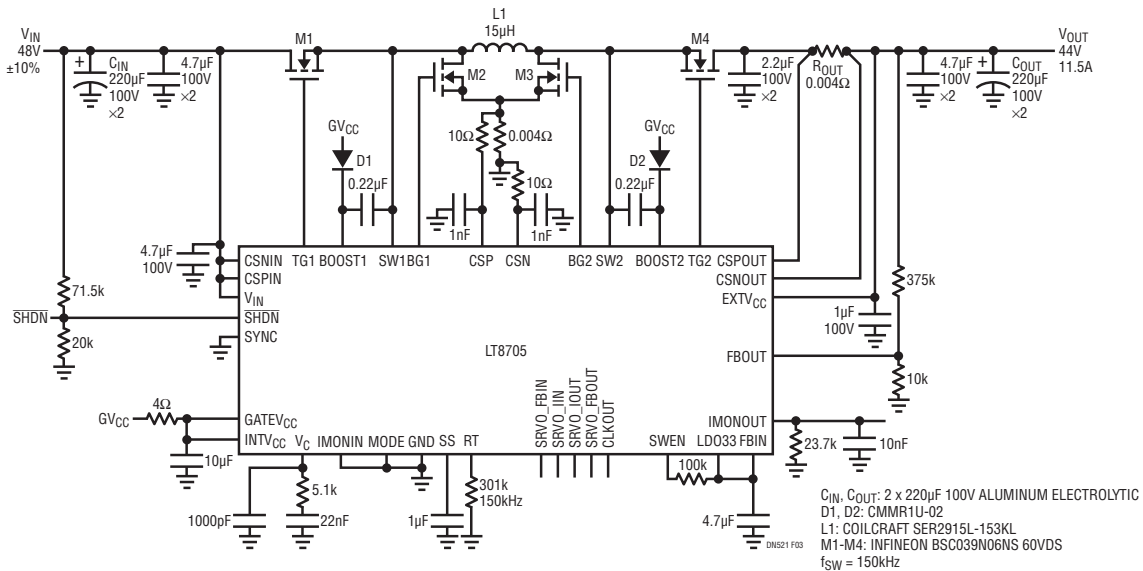

Figure 3. LT8705 500W, 44V, 11.5A Buck-Boost Converter for High Powered Battery Supply

Data Sheet Download

[www.linear.com/LT8705](http://www.linear.com/LT8705)

For applications help,  
call (408) 432-1900, Ext. 3550

Linear Technology Corporation  
1630 McCarthy Blvd., Milpitas, CA 95035-7417  
(408) 432-1900 • FAX: (408) 434-0507 • [www.linear.com](http://www.linear.com)

dn521f LT/AP 1213 111K • PRINTED IN THE USA

  
© LINEAR TECHNOLOGY CORPORATION 2013

# Bjarne Stroustrup: C++ Creator Keeps Developing The Language

**M**ention Bjarne Stroustrup's name to programmers, and they think of C++. That's not surprising since he came up with the object-oriented programming language and continues to be involved in the C++ standard, the latest being C++11.

Stroustrup has master's degrees in mathematics and computer science from Aarhus University in Denmark. His PhD in computer science is from the University of Cambridge. He has also taught and written about C++ with books like *Programming: Principles and Practice Using C++*. So how did he get started designing C++?

"I needed a tool to help me on a project where I needed hardware access, high performance for systems programming tasks, and help with handling complexity. The project was to 'split' a UNIX kernel into parts that could run on a multi-processor or a high-performance local network," Stroustrup said.

"At the time (1979/80), no language could meet all three requirements, so I added Simula-like classes to C. The earliest



**Bjarne Stroustrup created C++ and made programming history. He is still working on the latest revisions of the C++ standard.**

designs added function argument checking and conversion (what later became C function prototypes), constructors and destructors, and simple inheritance," he said.

"My earliest paper on 'C with Classes,' as it was called in the early years, used macros to implement a simple form of generic programming. Later I found that didn't scale and I had to add templates," he added (*see "Interview: Bjarne Stroustrup Discusses C++" at [electronicdesign.com](http://electronicdesign.com)*).

## C VERSUS C++

C++ started in 1979 when Bjarne was working on his PhD thesis. "The C++ Programming Language" was published in 1985. In 1998, the C++ standards committee published the first standard for C++ ISO/IEC 14882:1998. Now known as C++98, most C++ compilers support it. C++03 and C++11 then followed. The next revision will be C++14.

C++ shares quite a bit with C, but it was not a proper superset. C11 and C++11 are closer and share most of C's enhancements. Lambda, or anonymous functions, are part of C++11.

## C++'S AWFUL TEXTBOOKS—IN STROUSTRUP'S OWN WORDS

When I first was going to teach programming, I looked at the textbooks using C++, and I was furious! There were (and are) books teaching every little obscure detail of C before getting to the far easier to use C++ alternatives and deeming those alternatives "advanced" to scare off all but the most determined student.

Seriously, how could a standard-library vector be as hard to use well as a built-in

array? How could using `qsort()` be simpler than using the more general and efficient `sort()`? C++ provides better notational support and stronger type checking than C does. This can lead to faster object code.

Other books presented (and present) C++ as a somewhat failed attempt to be a "pure object oriented programming language" and force most every operation into class hierarchies (a la Java) with lots

of inheritance and virtual functions. The result is verbose code with unnatural couplings and lots of casting. To add insult to injury, such code also tends to be slow.

As I said, if that's C++, I don't like it either! I responded by writing *Programming: Principles and Practice Using C++*. It does not assume previous programming experience, though it has been popular with programmers wanting to know what C++ is about.

C++ also supports namespaces for grouping of entities like classes, objects, and functions.

Namespaces can be mixed together without conflicts that could be encountered with C when mixing libraries. The syntax of C++ is based on C. However, it adds quite a bit more including features like operators, operator overloading, templates, and, of course, object classes.

C++ supports static and dynamic polymorphism. It can also handle single-object and multiple-object inheritance. Java provides single inheritance support but allows interfaces per class. Virtual functions enable C++ to provide dynamic polymorphism. Objects can have constructor and destructor functions. C++ memory management includes static, automatic, and dynamic memory allocation. Libraries can support garbage collection.

Templates provide generic function support via parameterized types. Class and function templates are supported. Templates allow classes and functions to be instantiated at compile time. Compilers generate code as necessary when templates are utilized based on the defined types.

Part of the C++ standard is the C++ Standard Library. It provides features that C++ programmers have come to expect including smart pointers. It includes multithreading support, although C++11 includes native thread support within the language.

C++ is significantly more complex than C but there are significant advantages to using it. You don't have to learn all of those features to effectively use C++, though, so if you're looking to learn C or C++, I recommend C++.

C still dominates the embedded programming space, but C++ is overtaking it as more programmers learn C++ and more compilers support it. C++ has had a major impact in the consumer and enterprise space.

#### BEYOND THE CODE

Stroustrup headed up the Large-scale Programming Research department at AT&T Labs, formerly Bell Labs, until 2002. He is both an IEEE and ACM Fellow. These days he has little time to write a lot of C++ programs because he is teaching. He is now a Distinguished Professor at Texas A&M University, where he holds the College of Engineering Endowed Chair in Computer Science.

He still finds programming to be great fun. His advice to new programmers is to learn to communicate well verbally and in print. Of course, they also should learn programming fundamentals as well as several programming languages. **ed**

# FPGA Network Data Processing

PCIe-395N

PCIe-385N

PCIe-287N

- Latest generation of flexible FPGA systems
- Open, easy-to-use development architecture
- Full line rate data filtering and capture
- Ultra low latency connections
- Multiple network standards

**Nallatech**  
An Interconnect Systems, Inc. Subsidiary

[www.nallatech.com](http://www.nallatech.com) • [info@nallatech.com](mailto:info@nallatech.com)



## Microcontroller Solves Complex Temperature Polynomial Equations

RICARDO JIMENEZ AND ROBERTO C. SOLORIO | INSTITUTO TECNOLOGICO DE MEXICALI | ricardojimenezg@itmexicali.edu.mx

**WHEN YOU NEED TO** measure temperature using thermistors, you face the challenge of linearizing their response to get accurate readings. One of the best methods for linearizing a thermistor is the polynomial “Steinhart-Hart” equation (S-H), which has an error of 0.1°C. The temperature range for this design is from 0°C to 100°C.

Three thermistor coefficients—a, b, and c—are required to implement the S-H equation. If the manufacturer does not provide the coefficients, you can obtain them by solving the S-H equation (*Equations 1, 2, and 3*) for three different temperature points. In this design, a PIC MCU will solve such equations to provide accurate readings in 40 ms (*Fig. 1*).

To illustrate, we will use the negative-temperature-coefficient (NTC) LM103 thermistor, which has the resistance at three different temperatures shown in Table 1. With these three measurements, the temperature is converted to the Kelvin scale and substituted into three Steinhart-Hart equations:

$$T_1 = \frac{1}{a + b \ln(R_1) + c[\ln(R_1)]^3} \quad (1)$$

$$T_2 = \frac{1}{a + b \ln(R_2) + c[\ln(R_2)]^3} \quad (2)$$

$$T_3 = \frac{1}{a + b \ln(R_3) + c[\ln(R_3)]^3} \quad (3)$$

Solving these three equations yields the coefficients a, b, and c (*Table 2*). Substituting the coefficients in the Steinhart-Hart equation, we get the thermistor equation:

$$T_t = \frac{1}{2.501 \times 10^{-4} + 3.505 \times 10^{-4} (\ln(Rt)) - 1.415 \times 10^{-7} [\ln(Rt)]^3} \quad (4)$$

or:

$$T_t = \frac{10 \times 10^6}{(2501 + 3505 \ln(Rt) - 1.415 \ln(Rt)^3) / 10} \quad (5)$$

The challenge for the PIC 16F887 microcontroller is to use Equation 4 to get true temperature readings. This project consumes 1227 words of the microcontroller’s memory.

Input AN0 is declared as analog, and the rest of the I/O lines are declared digital outputs. The analog-to-digital converter (ADC) is configured for 10 bits, with a sampling time of 50 μs.

The thermistor’s voltage reading is stored in binary format in the variable “volt” with the instruction ADCIN 0, volt. Then, this reading is multiplied by 48,828 to convert it to decimal, and it is stored in a new variable called “v1.” To obtain each decimal digit from variable “v1,” the commands DIG3, DIG2, and DIG1 are used to store these readings in three variables called dig3, dig2, and dig, respectively.

The code, available with the online version of this article at *electronicdesign.com*, shows the software program where the following variables are declared for processing and storing the readings: B, A, C, L, volt, v1, v2, pattern, pattern2, pattern3, I, digit3, digit2, and digit. Two variables (conv1 and conv2) are required for binary-to-decimal conversions. They include the 10-bit resolution ADC’s least significant bit (LSB), which is equal to 4.8828 mV.

The algorithm that was developed to get a temperature reading using the Steinhart-Hart equation requires several steps.

First, compute the power supply voltage (v1), which is equal to 48828 × volt2. Variable volt2 is read with the PIC’s 10-bit ADC. If the power supply is correct, volt2 = %1111111111, and then v1 = 49,951,044. Now with the instruction DIV32,

TABLE 1: THERMISTOR RESISTANCE

Temperature (°C)	Resistance (kΩ)
2.7	23
27.5	8.8
66	2.7

TABLE 2: LM103 COEFFICIENTS

Coefficients	Value
A	2.501 × 10 <sup>-4</sup>
B	3.505 × 10 <sup>-4</sup>
C	-1.415 × 10 <sup>-7</sup>

## Ideas for Design

the variable volt2 is divided by 10,000, giving a result equal to 4995, which represents the approximate value of 5 V from the power supply.

Second, the thermistor's voltage drop is computed with the same process from the first step, but with another analog-to-digital channel. Let's say we have a reading in the ADC of 2.5 V ( $adc = 1000000000$ ). The voltage read is then 24,999,936, which is divided by 10 with DIV32 for a result of 2499, which approximates to 2.500 V.

Third, we proceed to find the resistor's value with:

$$R_2 = \frac{R_1 \times v_2}{E - v_2} \quad (6)$$

To achieve that, we store in a variable called "dif" the power's supply voltage minus the thermistor's voltage. Then we multiply the thermistor's voltage by the 10-k $\Omega$  fixed resistor, and we apply DIV32 to divide this last product by "dif," resulting in the thermistor's resistance value.

Fourth, we now compute the base 2 logarithm from the thermistor's resistance with Equations 7, 8, and 9:

$$M_1 = \left( \frac{M}{2^{a_0}} \right)^2 \quad (7)$$

$$M_2 = \left( \frac{M}{2^{a_1}} \right)^2 \quad (8)$$

$$M_3 = \left( \frac{M}{2^{a_2}} \right)^2 \quad (9)$$

where  $a_0$ ,  $a_1$ , and  $a_2$  are the next-digit mantissa in base 2.

Next, we find the characteristic  $a_0$  or logarithm's integer with the function NCD, which delivers the most significant bit (MSB) of a number. If we decrement it by 1, we get the base-2 logarithm characteristic. We know, for example, that the base-2 logarithm for number 47 is 5.554 using four significant digits. Thus, NCD (47) = 6, where 47 in binary is 00101111, and the MSB is in the sixth position from left to right. If we decrement it by 1, we get number 5, which is the logarithm's characteristic.

To get the logarithm, we need the Mantissa (fractions

part). To compute it, we need the result of the successive divisions "wu" by 2 (.). Nonetheless this operation or process cannot be applied directly, since dividing 47/2 results in 23.5, and we lose the fractions part. (PIC Basic Pro does not work with fractions.) Therefore, to keep the fractions part, we create a special subroutine that performs the following series:

$$\begin{aligned} 47/2 &= 23.5, 23.5/2 = 11.75, \\ 11.75/2 &= 5.875, 5.875/2 = 2.9375, 2.9375/2 = 1.46875 \end{aligned}$$

When dividing 47/2 = 23, with a remainder of 1, this "1" appears in the first division of the five that will be performed. Therefore, the fraction  $1/2^5 = 0.03125$ . We cannot work with fractions, though, so instead of dividing by 1 by  $2^n$ , we take the number 10,000 as a numerator, and we create a subroutine that computes the denominator depending on the number of division where appears a remainder of 1.

Then, we sum all the results of the divisions. To continue with this example, we have the following five steps:

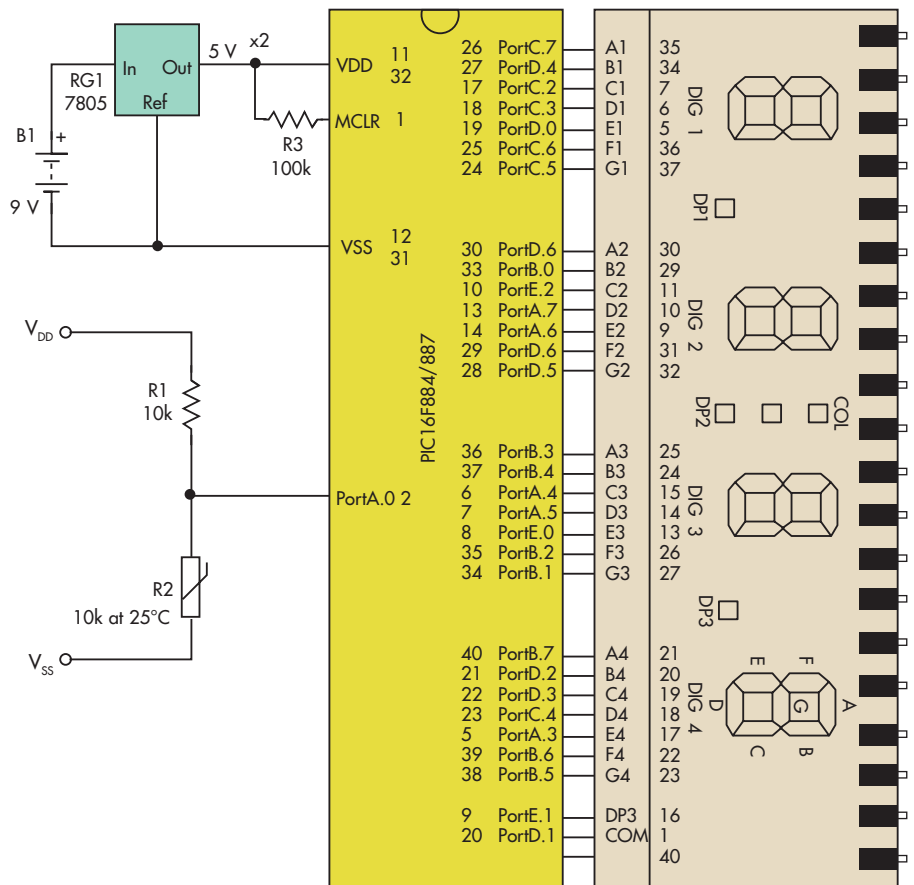

1. This simple circuit for a high-precision thermometer drives a glass LCD with high efficiency, using the PIC 16F887 microcontroller.



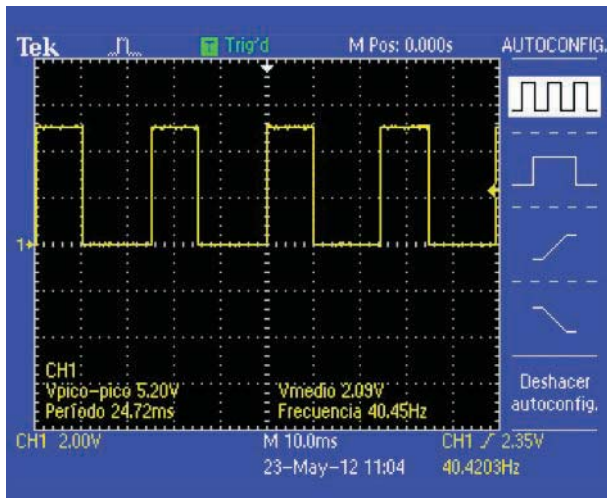

2. A signal at 40-Hz delivered by RC2 is used for driving the LCD's common pin.

- $47/2 = 23$ , with a remainder of 1; this is the first division of 5,  $10,000/2^5 = 312.5 = 312$
- $23/2 = 11$ , with a remainder of 1; this is the second division of 4,  $10,000/2^4 = 625$
- $11/2 = 5$ , with a remainder of 1;  $10,000/2^3 = 1250$
- $5/2 = 2$ , with a remainder of 1;  $10,000/2^2 = 2500$
- $2/2=1$ , with a remainder of 0; there is no portion to add

In this case the variable “Ja” is equal to 4687, and it still needs to be incremented by one. Therefore, we divide “Ja” by 1000 and then we add up 1000. Therefore,  $Ja = 1468$ , obtaining approximately the original quantity mentioned above, multiplied by 1000 with four significant digits.

Once we have obtained M, we need to get the mantissa using the process described in Figure 1. The division by  $2^{an}$  is not complicated because we are working in base 2, and the division is performed by  $2^0$  or  $2^1$ . When raising to the square power, we must account for where we will multiply  $M_a$  by  $M_a$ , and then we use that division by 1000 with DIV32 because the result is greater than 16 bits.

After this process is performed a required number of times, we need to convert  $a_n$  to a decimal base. To achieve this, we multiply by the respective weight, 5, 25, 125, and so on sequentially. And because we cannot work with fractions, we multiply by 5000, 2500, etc.

Finally, we add all the elements to the Mantissa  $a_n$  in decimal format and divide the sum of all of them by 10. We sum  $a_0 \times 1000$  and we save it in variable “l2,” so “l2” stores the value of the logarithm in base 2 of the thermistor’s impedance. The last step to obtain the natural logarithm is to apply the equation shown below to change its base:

## LINEARIZATION INSPIRES A SOLUTION

**WE ORIGINALLY CONCEIVED** of this idea as a solution to the problem faced by engineers in trying to linearize a thermistor’s response. We know there are analog methods to achieve this, such as putting a parallel resistor across the thermistor, constant current bias, or a combination of both. Then you get an almost linear response defined by a straight line. In this case, you have to design a signal conditioning circuit based on op amps, which adds more hardware to the project. Another option we had was using the thermistor’s characteristic equation, but it is not accurate over the entire temperature range. Therefore, we decided to use the venerable Steinhart-Hart equation.

With this in mind, we faced a new challenge: how to get the logarithm of a voltage reading. This had to be done without getting overflow errors in the microcontroller. After trying with different methods (Taylor series, Babylonian, etc.), we found that the most appropriate algorithm for this project was the one from Dr. G. Mayer in his paper “computing logarithms digit-by-digit.” So the method was developed in base two, and at the end of the process, it was converted to base 10. Once this was achieved, the final step was to substitute the resulting Ln values into the S-H equation to get accurate temperature readings.

The total algorithm’s processing time was 32 ms with the internal microcontroller’s oscillator set at 4 MHz. Some readers have been asking how to reduce the processing time. It can be reduced to less than 10 ms by selecting a higher oscillator’s frequency in the algorithm itself.

We decided to drive a numerical LCD directly without external decoders for energy-saving applications. You can choose other types of displays to free the microcontroller’s ports for other control applications. We are currently working with tiny eight-pin based microcontrollers driving serial displays. The advantage of designing algorithms is that you can transfer them to any microcontroller, and you don’t need to be tied to a specific structured language.

## CORRECTION

**“BUILD A HIGH-FREQUENCY** Portable Spectrum Analyzer Using Two Filter ICs” by in our Oct. 17 issue repeated Figure 2 as Figures 3 and 4. See <http://electronicdesign.com/test-amp-measurement/build-high-frequency-portable-spectrum-analyzer-using-two-filter-ics> for the correct figures.

# Find the right SOLUTION for your APPLICATION

## ULTRASOUND ICs

- Pulsers
- Multiplexer/Switches
- MOSFET Drivers
- T/R Switches



## LED DRIVERS

- Buck
- Boost
- Flyback
- SEPIC



## HIGH VOLTAGE DRIVER ICs

- Push-Pull
- Open Drain Source
- Open Drain Sink



## EL DRIVERS

- Inductorless
- Single Segment
- Multi Segment



## MOSFETs

- Depletion Mode
- Enhancement Mode
- MOSFET Arrays
- IGBT

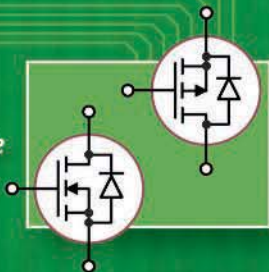

**Supertex inc**  
www.supertex.com



## Ideas for Design



3. The yellow signal is the logarithm's processing time of 33 ms. The 7-ms blue line is the time required to get a true reading by the MCU. Thus, the total processing time is 40 ms.

$$\log_2 x (\ln 2) = \ln x$$

We know that  $\ln(2) = 0.6931$ , so we just need to multiply "12" by 6931 and then divide it by 10,000 using the DIV32 command to store it in variable "1m," which is the natural logarithm of the resistor multiplied by 1000.

To drive the common pin of the LCD, a for-next loop enables the output RC2 to be "1" (Fig. 2). Then the subroutine "D" is invoked to convert the decimal data to a seven-segment code. The LOOKUP function decodes the decimal value of digit3 to a seven-segment format that is stored in variable pattern3. Now the value of RC2 (stored as a byte in variable L) is XORED with pattern3 to drive the LCD in phase.

This process is repeated with the other two digits while a 10-ms pause is added. Then, RC2 is turned off and stored as a byte in variable L. Subroutine D is invoked again and the process is repeated with the phase output (RC2) changed for another 10 ms. After every LOOKUP function, every pin is assigned to the corresponding port's pin dedicated to drive each LCD segment. Total time required is 40 ms (Fig. 3). 

## Reference

*Computing Logarithms Digit-by-Digit*, Mayer Goldberg, BRICS RS-04-17. ISSN: 0909-0878

**RICARDO JIMENEZ** holds a master's degree in electronics from ITM. He is an adjunct professor at Imperial Valley College, Imperial, Calif. **ROBERTO C. SOLORIO** holds a BS in electronics from ITM. He is a test engineer at Skyworks in Mexicali, Mexico.

**DirectConnection**

Texas Instruments is looking to fill engineering positions working with semiconductor technologies. We are recruiting @ various educational and experience levels:

**Manchester, NH**

- **Analog Design Engineer** - <http://tinyurl.com/mfutut9>

**Phoenix, AZ**

- **Applications Engineer** - <http://tinyurl.com/oervdb8>
- **Analog Design Engineer** - <http://tinyurl.com/pxw8ket>

**Santa Clara, CA**

- **Production Planning Analyst** - <http://tinyurl.com/lech9tu>

**Stafford, TX**

- **Applications Manager** - <http://tinyurl.com/pfv2kpa>

**Tucson, AZ**

- **Product Definer** - <http://tinyurl.com/lobpk3s>

Some positions may require some travel. Please send in resumes using the individual URL code for the position listed. EOE.



**Attention Advertisers:**  
For digital ad specifications and requirements, please visit the Ad Production web site:  
[www.pentondigitalads.com](http://www.pentondigitalads.com)

**IR's AUIRF8736M2 Automotive DirectFET®2 Power MOSFET Delivers Increased Power Density While Reducing Overall System Size and Cost**

IR has announced the introduction of the AUIRF8736M2 DirectFET®2 power MOSFET for heavy load automotive applications including electric power steering, braking systems and pumps that require superior power density in a compact footprint.



Leveraging IR's benchmark COOLiRFET™ silicon technology, the 40V AUIRF8736M2 offers a 40% improvement in on-state resistance (Rds(on)) compared to previous generation devices to help minimize conduction losses. The dual-side cooling Medium Can DirectFET®2 power package delivers excellent thermal performance and low parasitic inductance.

The device is qualified according to AEC-Q101 standards, features an environmentally-friendly 100% lead-free package and RoHS compliant bill of materials, and is part of IR's automotive quality initiative targeting zero defects.

More information is available on the **International Rectifier** website at <http://www.irf.com/whats-new/nr131010.html>

For more information, contact Sian Cummins, [scummin1@irf.com](mailto:scummin1@irf.com), 310-252-7148.

**HIGH VOLTAGE DIODES**

**Compact Size, Medium Current**

Exceptionally compact high voltage diodes (2kV, 3kV and 4kV with average current up to 850mA) the UFHV series is available in D0-41 package with a  $T_{rr}$  of 75nSec. Applications include High Voltage Power Supplies and Multipliers found in instrumentation, plasma displays and electrophoresis where small physical size and high voltage-medium current is required.

**HVCA**  
(732) 938-4499 • (732) 938-4451 FAX  
e-mail: [info@hvca.com](mailto:info@hvca.com)  
[www.hvca.com](http://www.hvca.com)

**DEAN TECHNOLOGY** HVCA Products by Dean Technology

**OTTER**  
COMPUTER INC.  
Since 1989

**PCB Layout Design**  
**Prototype & Production**

**Best Quality ! Best Price**

Call more information at 408-982-9358  
E-mail: [Sales@otterusa.com](mailto:Sales@otterusa.com)  
[WWW.OTTERUSA.COM](http://WWW.OTTERUSA.COM)

Ad	Page	Ad	Page	Ad	Page
ACCES I/O Products Inc. ....	53	Equipto Electronics Corp. ....	62	Penton Salary Survey .....	1
Advanced Assembly.....	Fca/b	ExpressPCB .....	29	Pico Electronics Inc. ....	16
Advanced Interconnections Corp.....	10	Fisher Elektronik.....	57	Pico Electronics Inc. ....	25
Agilent Technologies .....	11	Fluke Corp. ....	IBC	Rittal Corp.....	50-51
Agilent Technologies .....	33	Front Panel Express .....	48	Rohde & Schwarz .....	34-35
Ametherm .....	31	International Rectifier .....	4	Rohde & Schwarz .....	47
ARM .....	64	Keystone Electronics Corp.....	17	SanDisk Corp.....	37
Avnet.....	15	Linear Technology .....	64a/b	Shenzhen Fastprint.....	36
Avnet.....	41	Linear Technology .....	BC	Supertex Inc. ....	70
Coilcraft .....	9	Memory Protection Devices Inc. ....	2	TE Connectivity .....	18-19
CUI Inc.....	27	Mouser Electronics .....	6	TTI .....	43
Datatronics .....	61	Mouser Electronics .....	38		
Dean Technology .....	48	Nallatech/Interconnect Systems.....	66		
Digi-Key.....	FC	National Instruments.....	12		
Digi-Key.....	IFC	Newark.....	3		

For more information on products or services visit our website [www.electronicdesign.com](http://www.electronicdesign.com), menu item Reader Service. The advertisers index is prepared as an extra service. *Electronic Design* does not assume any liability for omissions or errors.



# Where Did My PC Go? It's Gone Gaming

PCs still reside on desktops, and plenty of laptops remain too. But there has been an overall decline in their numbers due to the popularity of other platforms such as smart phones and tablets. However, PC platforms are showing up on the gaming front.

This holiday season the retail shelves are packed with the Microsoft Xbox One (Fig. 1) and Sony PlayStation 4 (PS4) (Fig. 2), which are pretty similar under the hood. Both employ an eight-core AMD Accelerated Processing Unit (APU) that also includes a multicore Radeon GPU.

## HARDWARE & SOFTWARE

The Xbox One and PlayStation 4 look a lot like PCs, including Ethernet, Wi-Fi (801.11 b/g/n), and USB 3.0 ports. The big difference is that neither gaming console runs standard PC operating systems like Windows 8 or Linux. The Xbox One essentially has Windows 8 under the hood, but it's customized for gaming. It isn't running Word at this point.

Unlike their predecessors, these platforms now can run these operating systems. The PS3's Cell processor was a challenge for gaming programmers. Microsoft's previous Xbox had a more conventional processor, but not one that would match anything on the PC market.

The AMD APUs in the latest systems may not match those available on general PC platforms, but they are very close. This will make it easier for developers to create games that span PCs as well as the PS4 and Xbox One. Of course, differences in each platform's operating system and graphics interface will likely annoy developers who need to deliver multiplatform games.

There are a couple of new gaming systems around, including Ouya's \$99 Android platform. It runs an NVidia Tegra3 that makes it underpowered compared to the AMD APU in the Xbox One or PS4, but it is quite a bit cheaper.

The other gaming system on the horizon is Valve's Steam Machine (Fig. 3). This PC runs Valve's SteamOS, which is a customized version of Linux. Valve wants to turn its PC success into the next popular gaming platform. Its Steam platform has been popular on Windows PCs. I spend too much time running Digital Extremes' Warframe, which is a free download via Steam. It will also be available on the PS4.



1. Microsoft's Xbox One employs a new Kinect 3D time-of-flight sensor.



2. Sony's PS4, like the Xbox One, utilizes a multicore AMD Advanced Processing Unit. Both have eight Jaguar CPU cores and an AMD Radeon GPU.



3. Valve's Steam Machine runs the Linux-based Steam operating system, which can run on stock PC hardware.

## APPLICATIONS

Gaming is the primary purpose for these platforms, but they all provide a range of multimedia services including Netflix, Amazon, and Blockbuster video streaming. They all have built-in network browsers, although they aren't always as functional or as easy to use as those found on other platforms.

The advantage of more PC-like platforms is the possibility of other, non-game applications, such as telemedicine and finance. The platform similarity allows applications that originally were designed for the PC to be ported to new platforms. These gaming platforms offer some useful hardware for features like video conferencing as well. So if you're holiday shopping for a new gaming system, you might wind up with another PC in the house. 

Follow Bill Wong on Twitter at #AllEmbedded.

Become a fan at facebook.com/ElectronicDesign.



# THE LEGACY OF LEADERSHIP CONTINUES



**After 20 years, Fluke ScopeMeter® industrial scopes still lead, now with 500 MHz bandwidth and 5 GS/s sampling speed.**

The Fluke 190 Series II extends your troubleshooting arsenal, showing you waveform shape, timing, distortion and disturbance in greater detail than ever before. Two- and four-channel models fit any application, measuring signals from 60 MHz to 500 MHz. ScopeMeter® test tools are number one in ruggedness: the only completely sealed, drip-proof, dust-proof IP-51 rated scopes.



Watch ScopeMeter 190-II Scenario Videos:  
[www.fluke.com/scopemeter500](http://www.fluke.com/scopemeter500)

**FLUKE**®

©2012 Fluke Corporation  
AD 4282291A\_EN

# Big Volts. Small Solution.

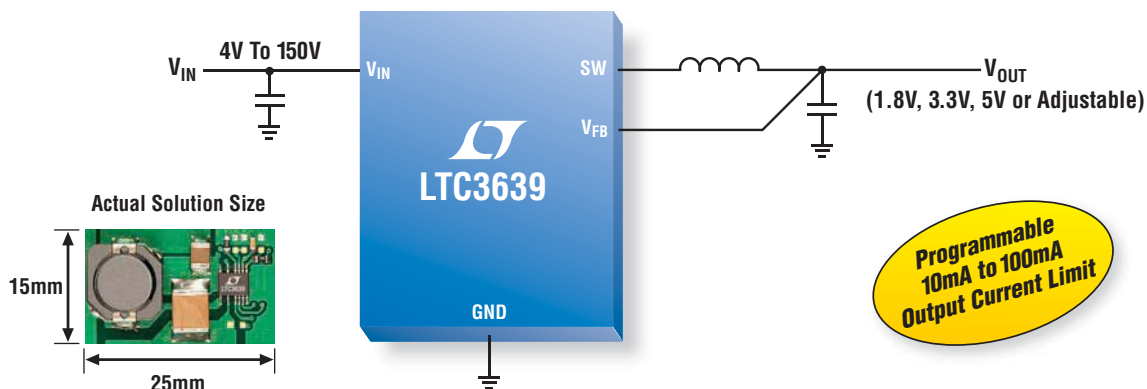

150V, 100mA,  $I_Q = 12\mu\text{A}$ , Sync Buck.

Some things may be considered mutually exclusive, but not for our LTC<sup>®</sup>3639. It is a monolithic synchronous buck converter with a 4V to 150V input voltage range, programmable undervoltage lockout and high efficiency conversion. Features include a quiescent current of only 12 $\mu\text{A}$ , 100% duty cycle operation, a user-programmable current limit from 10mA to 100mA and internal compensation. The LTC3639 provides best-in-class performance for a myriad of applications from industrial control systems and medical devices to automotive and avionic electronics. That's a lot of capability in a simple, compact solution.

## Selected Monolithic Buck Converters

Part Number	V <sub>IN</sub> Range (V)	Output Current (mA)	Quiescent Current ( $\mu\text{A}$ )	Package
LTC3642	4.5 to 45	50	12	MSOP8E, DFN
LTC3631	4.5 to 45 (60 Trans)	100	12	MSOP8E, DFN
LTC3632	4.5 to 50 (60 Trans)	20	12	MSOP8E, DFN
LTC3630	4 to 65	50 to 500	12	MSOP16E <sup>†</sup> , DFN
LTC3630A	4 to 76	50 to 500	12	MSOP16E <sup>†</sup> , DFN
LTC3639	4 to 150	10 to 100	12	MSOP16E <sup>†</sup>
LTC3638*	4 to 150	25 to 250	12	MSOP16E <sup>†</sup>

\* Future Product  
<sup>†</sup> 4 Pins Removed for High Voltage

## Info & Free Samples

[www.linear.com/product/LTC3639](http://www.linear.com/product/LTC3639)

1-800-4-LINEAR

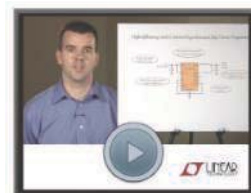

[video.linear.com/170](http://video.linear.com/170)

LT, LT, LTC, LTM, Linear Technology and the Linear logo are registered trademarks of Linear Technology Corporation. All other trademarks are the property of their respective owners.

