

POWER MANAGEMENT

SAM DAVIS

POWER

SUPPLIES

SYSTEMS

APPLICATIONS

COMPONENTS

SEMICONDUCTORS



CHAPTER 7: VOLTAGE REGULATOR ICs

Virtually all power supplies employ semiconductors to provide a regulated output voltage. If the supply has an ac input, it is rectified to be a dc voltage. A power converter IC accepts the dc input and produces a dc output or controls external power output semiconductor switches to produce a dc output. It is a voltage regulator when its output voltage is fed back to a circuit that causes the voltage remains constant. If the output voltage tends to rise or fall, the feedback causes the output to remain the same.

The power converter can operate either as a switch-mode or linear circuit. In a linear configuration, the controlling transistor always dissipates power, which can be minimized by using low dropout regulators (LDOs) that regulate properly even when there is a relatively low voltage differential between their input and output. LDO ICs have simpler circuits than their switch-mode cousins and produce less noise (no switching), but are limited by their current-handling and power dissipation capability. Some LDO ICs are specified at about 200mA and others can handle up to about 1A.

Efficiency of the LDO ICs may be 40-60%, whereas the switch-mode ICs can exhibit up to 95% efficiency. Switch-mode topologies are the primary approach for embedded systems, but LDOs also find use in some applications.

Low Dropout (LDO) Linear Regulator

LDO linear regulators are usually employed in systems that require a low-noise power source instead of a switching regulator that might upset the system. LDOs also find use in applications where the regulator must maintain regulation with small differences between the input supply voltage and output load voltage, such as battery-powered systems. Their low dropout voltage and low quiescent current make them a good fit for portable

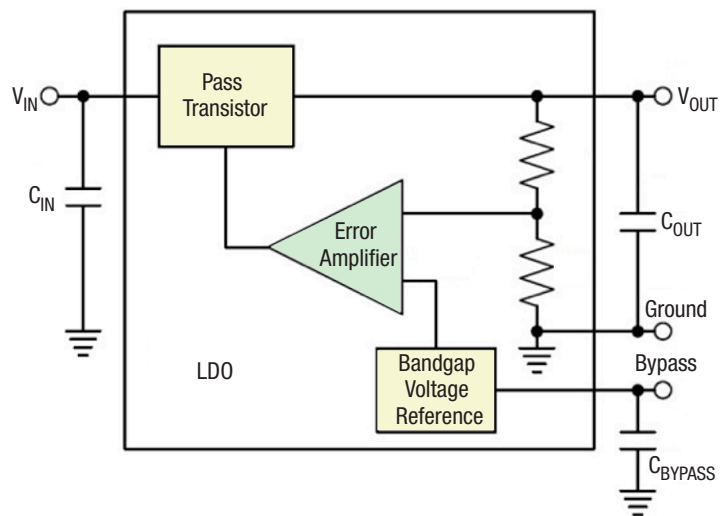

7-1. In the basic LDO, one input to the differential error amplifier, set by resistors R1 and R2, monitors a percentage of the output voltage. The other error amplifier input is a stable voltage reference (V_{REF}). If the output voltage increases relative to V_{REF} , the differential error amplifier changes the pass-transistor's output to maintain a constant output load voltage (V_{OUT}).

and wireless applications. LDOs with an on-chip power MOSFET or bipolar transistor typically provide outputs in the 50 to 500mA range.

An LDO voltage regulator operates in the linear region with the topology shown in Fig. 7-1. As a basic voltage regulator, its main components are a series pass transistor (bipolar transistor or MOSFET), differential error amplifier, and precise voltage reference.

Key operational factors for an LDO are its dropout voltage, power-supply rejection ratio (PSRR), and output noise. Low dropout refers to the difference between the input and output voltages that allow the IC to regulate

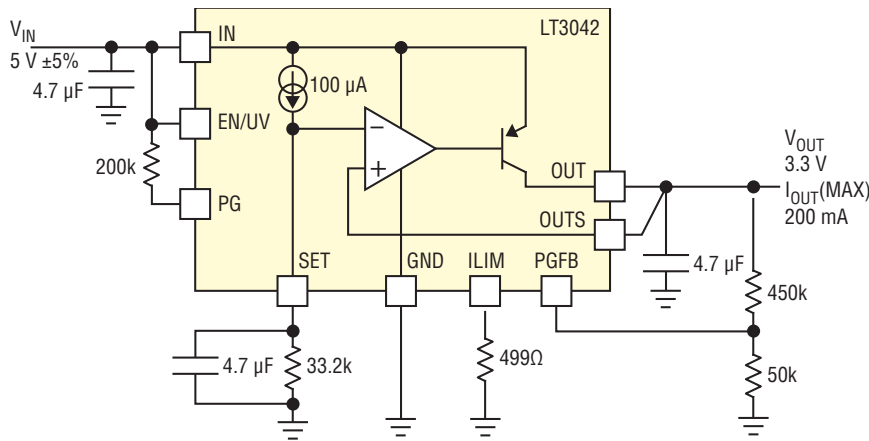

7-2. The LT3042 is an LDO that uses a unique architecture to minimize noise effects and optimize Power Supply Ripple Rejection (PSRR).

the output load voltage. That is, an LDO can regulate the output load voltage until its input and output approach each other at the dropout voltage. Ideally, the dropout voltage should be as low as possible to minimize power dissipation and maximize efficiency. Typically, dropout is considered to be reached when the output voltage has dropped to 100mV below its nominal value. The load current and pass transistor temperature affect the dropout voltage.

An LDO's internal voltage reference is a potential noise source, usually specified as microvolts RMS over a specific bandwidth, such as 30 μV RMS from 1 to 100 kHz. This low-level noise causes fewer problems than the switching transients and harmonics from a switch-mode converter. In Fig. 7-1, the LDO has a (voltage-reference) bypass pin to filter reference voltage noise with a capacitor to ground. Adding the datasheet-specified input, output, and bypass capacitors usually results in a non-problematic noise level.

Among their operational considerations are the type and range of the applied input voltage, required output

voltage, maximum load current, minimum dropout voltage, quiescent current, power dissipation, and shutdown current.

Controlling the LDO's frequency compensation loop to include the load capacitor reduces sensitivity to the capacitor's ESR (equivalent series resistance), which allows a stable LDO with good quality capacitors of any type. In addition, output capacitor placement should be as close as possible to the output.

Additional features in some LDOs are:

- An enable input that allows external control of LDO turn-on and turn-off.
- Soft-start that limits inrush current and controls output voltage rise time during power-up.
- A bypass pin that allows an external capacitor to reduce reference voltage noise.
- An error output that indicates if the output is going out of regulation.
- Thermal shutdown that turns the LDO off if its temperature exceeds the specified amount.
- Overcurrent protection (OCP) that limits the LDO's output current and power dissipation.

LT3042

The LT3042 from Linear Technology is a low dropout (LDO) linear regulator that uses a unique architecture to minimize noise effects and optimize Power-Supply Ripple Rejection (PSRR).

PSRR describes how well a circuit rejects ripple, injected at its input. The ripple can be either from the input supply such as a 50Hz/60Hz supply ripple, switching ripple from a DC/DC converter, or ripple due to the sharing of an input supply with other circuits.

For LDOs, PSRR is a function of the regulated output voltage ripple compared to the input voltage ripple over a given frequency range (typically 10Hz to 1MHz), expressed in decibels (dB). It can be an important factor when an LDO powers analog circuits because a low PSRR may allow output ripple to affect other circuits.

Low-ESR output capacitors and added reference voltage bypass capacitors improve the PSRR performance. Battery-based systems should employ LDOs that maintain high PSRR at low battery voltages.

The LT3042 shown in the simplified schematic of Fig. 7-2 is an LDO that reduces noise and increases PSRR. Rather than a voltage reference used by most traditional linear regulators, the LT3042 uses a current reference that operates with a typical noise current level of $20\text{pA}/\sqrt{\text{Hz}}$ (6nARMS over a 10Hz to 100kHz bandwidth).

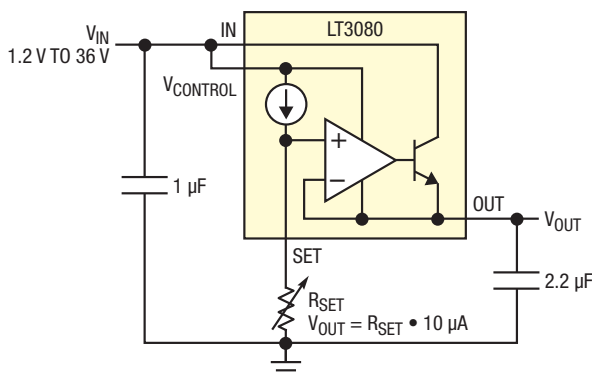

7-3. The LT3080 can program output voltage to any level between zero and 36V.

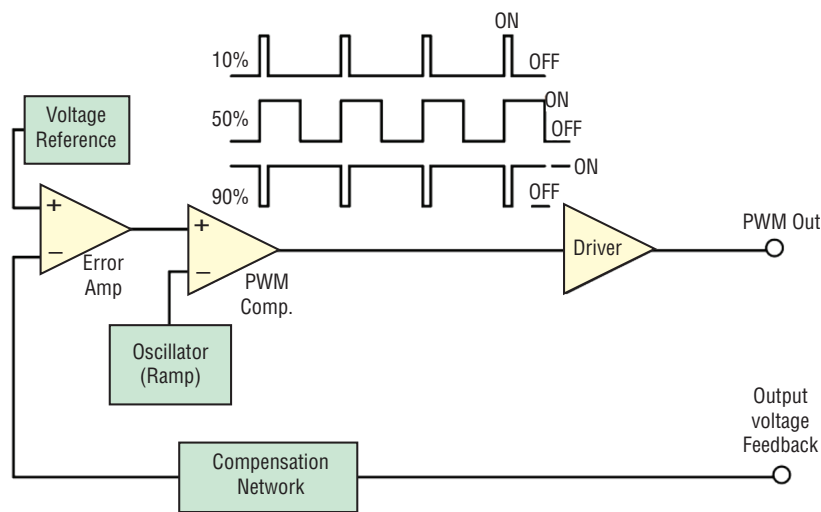

7-4. A PWM controller produces square waves of different widths dependent on the out voltage feedback.

The current source is followed by a high performance rail-to-rail voltage buffer, allowing it to be easily paralleled to further reduce noise, increase output current and spread heat on a PCB. Paralleling multiple LT3042s further reduces noise by a factor of \sqrt{N} , where N is the number of parallel circuits.

LT3080

Linear Technology’s LT3080 is a unique, 1.1A LDO that you can paralleled to increase output current or spread heat in surface-mounted boards (Fig. 7-3). This IC brings out the collector of the pass transistor to allow low dropout operation—down to 350 mV—when used with multiple supplies. Protection features include short-circuit and safe operating area protection, as well as thermal shutdown.

A key feature of the LT3080 is the capability to supply a wide output voltage range. By using a reference current through a single resistor, the output voltage is programmed to any level between zero and 36V. It is stable with 2.2 μ F of capacitance on the output, and can use small ceramic capacitors that do not require additional

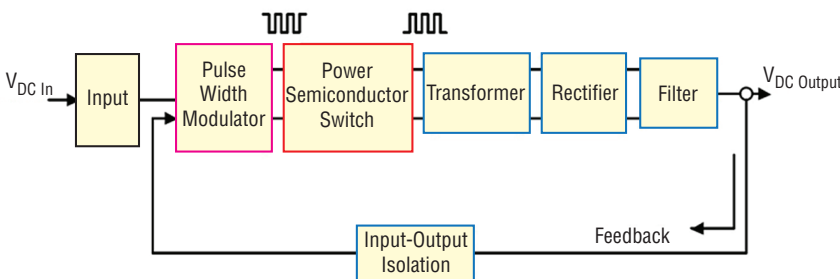

7-5. Switch-mode converter uses pulse width modulator to control regulation

ESR, unlike other regulators.

The LT3080 is especially well suited to applications needing multiple rails. Its architecture adjusts down to zero with a single resistor handling modern low-voltage digital ICs as well as allowing easy parallel operation and thermal management without heat sinks. Adjusting to “zero” output allows shutting off the powered circuitry and when the input is pre-regulated—such as a 5V or 3.3V input supply—external resistors can help spread the heat.

A precision “0” TC 10 μ A internal current source connects to the non-inverting input of its power operational amplifier, which provides a low-impedance buffered output to the voltage on the non-inverting input. A single resistor from the non-inverting input to ground sets the output voltage; setting this resistor to zero produces zero output. Any output voltage can be obtained from zero up to the maximum defined by the input power supply.

Use of a true current source allows the regulator to exhibit gain and frequency response independent of the positive input impedance. Older adjustable regulators change their loop gain with output voltage and change bandwidth when bypassing their adjustment pin. For the LT3080, the loop gain is unchanged by changing the output voltage or bypassing. Output regulation is not fixed at a percentage of the output voltage but is a fixed fraction of millivolts. Use of a true current source allows all the gain in the buffer amplifier to provide regulation and none of that gain is needed to boost the reference to a higher output voltage.

The IC can operate in two modes. One is the three-terminal mode that connects the control pin to the power input pin, which limits it to 1.35V dropout. Alternatively, you can connect the “control” pin to a higher voltage and the power IN pin to a lower voltage, resulting in 350mV dropout on the IN pin and minimizing the power dissipation. This allows a 1.1A supply regulating from 2.5VIN to 1.8VOUT or 1.8VIN to 1.2VOUT with low dissipation.

Switch-Mode ICs

Figure 7-4 shows a simplified PWM controller employed with a switch-mode converter. In operation, a fraction of the dc output voltage feeds back to the error amplifier, which causes the comparator to control the PWM ON and OFF times. Figure 7-4 shows how the PWM pulse width changes for different percentages of ON and OFF times. The longer the ON time,

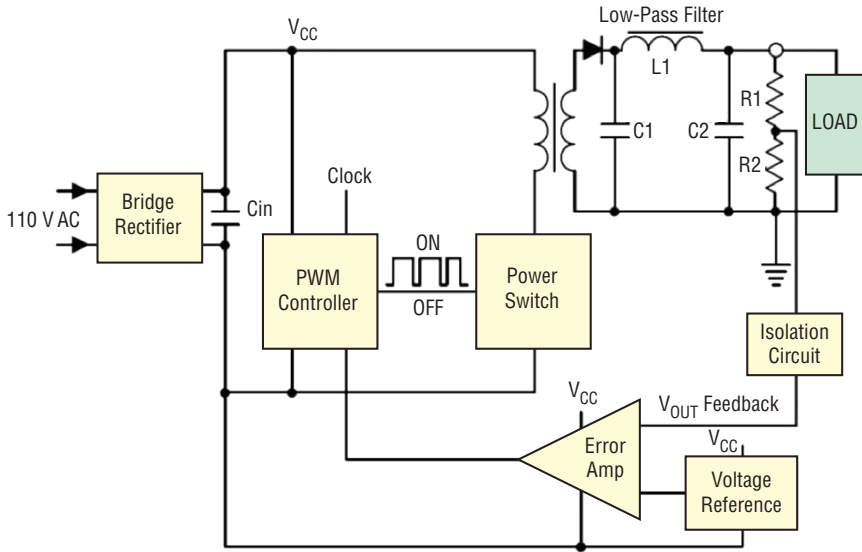

7-6. Isolated switch-mode converter employs a transformer for isolation.

the higher the rectified dc output voltage. Output voltage regulation is maintained if the power MOSFET's filtered output tends to change, if this occurs feedback adjusts the PWM duty cycle to keep the output voltage at the desired level.

To generate the PWM signal, the error amplifier accepts the feedback signal input and a stable voltage reference to produce an output related to the difference of the two inputs. The comparator compares the error amplifier's output voltage with the ramp (sawtooth) from the oscillator, producing a modulated pulse width. The comparator output is applied to the switching logic, whose output goes to the output driver for the external

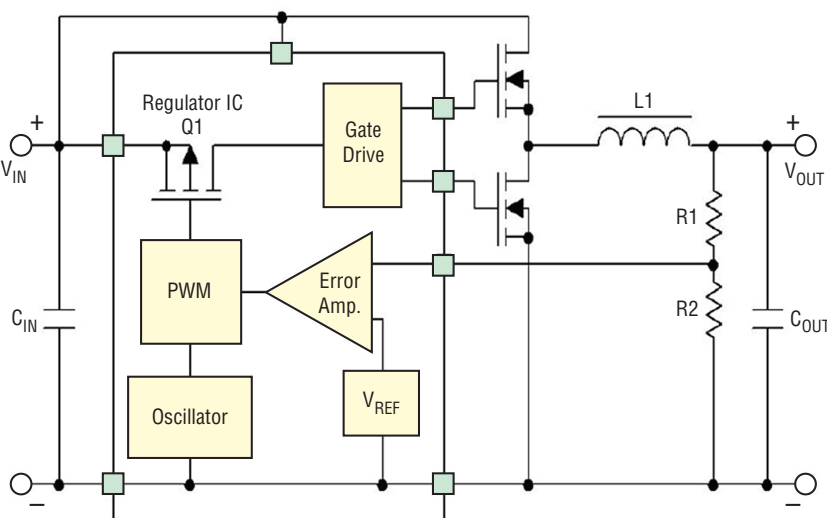

7-7. Non-isolated switch-mode converter.

power MOSFET. The switching logic provides the capability to enable or disable the PWM signal applied to the power MOSFET.

Most PWM controller ICs provide current limiting protection by sensing the output current. If the current sense input exceeds a specific threshold, it terminates the present cycle (cycle-by-cycle current limit).

Circuit layout is critical when using a current sense resistor, which must be a low inductance type. Locate the current sense filter capacitor very close to and connected directly to the PWM IC pin. Also, all the noise-sensitive low-power ground connections should be connected together near the IC GND and a single connection should be made to the power ground (sense resistor ground point).

In most PWM controller ICs, a single external resistor or capacitor sets the oscillator frequency. To set a desired oscillator frequency, use the equation in the controller datasheet to calculate the resistor value.

Some PWM converters include the ability to synchronize the oscillator to an external clock with a frequency that is either higher or lower than the frequency of the internal oscillator. If there is no requirement for synchronization, connect the sync pin to GND to prevent noise interference.

Because the PWM IC is a part of feedback circuit, the input to the error amplifier must employ a frequency compensation network to ensure system stability.

A typical power converter accepts a dc input, converts it to the switching frequency and then rectifies it to produce the dc output. A portion of its dc output is compared with a voltage reference (V_{REF}) and controls the PWM. If the output voltage tends to increase, the voltage fed back to the PWM circuit reduces its duty cycle, causing its output to reduce and maintain the proper regulated voltage. Conversely, if the output voltage tends to go down, the feedback causes the power-switch duty cycle to increase, keeping the regulated output at its proper voltage.

Typically, the power semiconductor switch turns on and off at a frequency that may range from 100kHz to 1MHz, depending on the IC type. Switching frequency determines the physical size and value of filter inductors, capacitors, and transformers. The higher the switching frequency, the smaller the physi-

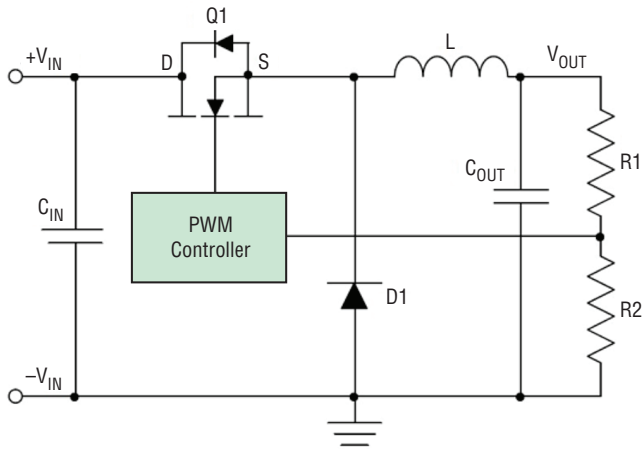

7.8. Basic buck converter; inductor always “bucks” or acts against the input voltage

cal size and component value. To optimize efficiency, magnetic core material for the inductor and transformer should be consistent with the switching frequency. That is, the transformer/inductor core material should be chosen to operate efficiently at the switching frequency.

Figure 7-5 shows a simplified diagram of a switch-mode voltage regulator. Switch-mode dc-dc converters require a means to vary their output voltage in response to changes in their load. One approach is to use pulse-width modulation (PWM) that controls the input to the associated power switch. The PWM signal consists of two values, ON and OFF. A low-pass filter connected to the output of the power switch provides a voltage proportional to the ON and OFF times of the PWM controller.

There are two types of switch-mode converters: isolated and non-isolated, which depends on whether there is a direct dc path from the input to the output. An isolated converter employs a transformer to provide isolation between the input and output voltage (Fig. 7-6). The non-isolated converter usually employs an inductor and there is no voltage isolation between the input and output (Fig. 7-7). For the vast majority of applications, non-isolated converters are appropriate. However, some applications require isolation between the input and output voltages. An advantage of the transformer-based converter is that it has the ability to easily produce multiple output voltages, whereas the inductor-based converter provides only one output.

Circuit Topologies

There are two basic IC topologies employed in dc power converters. If the output is lower than the input voltage, the IC is said to be a step-down, or buck converter. If the output is higher than the input voltage, the

IC is said to be a step-up, or boost converter.

In its basic circuit (Fig. 7-8), the buck regulator accepts a dc input, converts it to a PWM (pulse-width modulator) switching frequency that controls the output of the power MOSFET (Q1). An external rectifier, inductor, and output capacitor produce the regulated dc output. The regulator IC compares a portion of the rectified dc output with a voltage reference (VREF) and varies the PWM duty cycle to maintain a constant dc output voltage. If the output voltage tends to increase, the PWM reduces its duty cycle causing the output to reduce and keeping the regulated output at its proper voltage. Conversely, if the output voltage tends to go down, the feedback causes the PWM duty cycle to increase and maintain the regulated output.

The buck, or step-down regulator topology has advantages of simplicity and low cost. However, it has a limited power range and its direct dc path from input to output can pose a problem if there is a shorted power switch.

LT8602

The LT8602 from Linear Technology is a constant-frequency, current-mode, monolithic buck-switching regulator with four output channels (Fig. 7-9). Two are high-voltage channels with a 3V to 42V input and the other two are low-voltage channels with a 2.6V to 5.5V input

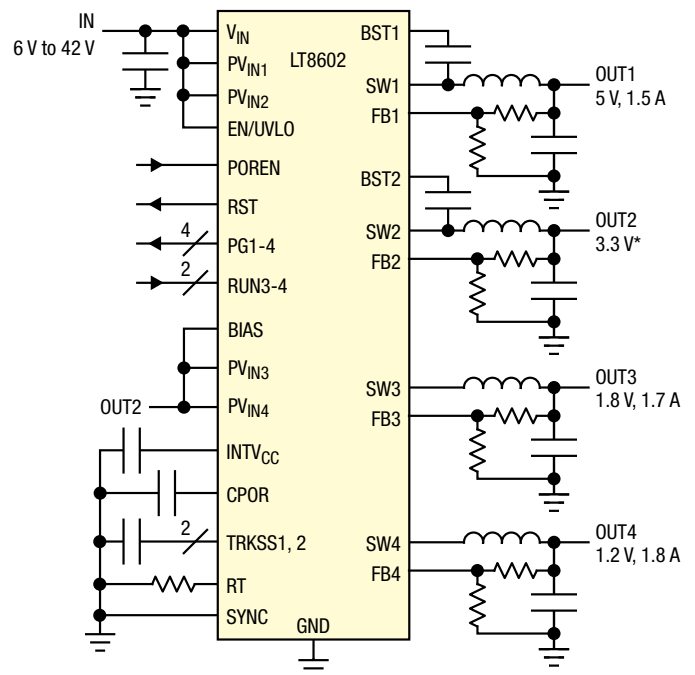

* $OUT2 = 2.5 A - I_{PVIN3} - I_{PVIN4}$

7-9. LT8602 Quad buck converter has two high-voltage channels with a 3V to 42V input and the other two are low-voltage channels with a 2.6V to 5.5V input.

input.

The IC employs a single oscillator that generates two clock (CLK) signals 180 deg. out of phase. Channels 1 and 3 operate on CLK1, while channels 2 and 4 operate on CLK2. A buck regulator only draws input current during the top switch on cycle, so multiphase operation cuts peak input current and doubles the input current frequency. This reduces both input current ripple and the required input capacitance.

Each high-voltage (HV) channel is a synchronous buck regulator that operates from its own PVIN pin. The internal top-power MOSFET turns on at the beginning of each oscillator cycle, and turns off when the current flowing through the top MOSFET reaches a level determined by its error amplifier. The error amplifier measures the output voltage through an external resistor divider tied to the FB pin to control the peak current in the top switch.

While the top MOSFET is off, the bottom MOSFET is turned on for the remainder of the oscillator cycle or until the inductor current starts to reverse. If overload conditions result in more than 2A (Ch 1) or 3.3A (Ch 2) flowing through the bottom switch, the next clock cycle will be delayed until switch current returns to a lower, safe level.

High-voltage channels have Track/Soft-Start Inputs (TRKSS1, TRKSS2). When this pin is below 1V, the converter regulates the FB pin to the TRKSS voltage instead of the internal reference. The TRKSS pin has a 2.4 μ A pull-up current. The TRKSS pin can also be used to allow the output to track another regulator, either the other HV channel or an external regulator.

As shown in the simplified inductive-boost dc-dc converter circuit (Fig. 7-10), turning on the power MOSFET causes current to build up through the inductor. Turning off the power MOSFET forces current through the diode to the output capacitor. Multiple switching cycles build the output capacitor voltage due to the charge it stores from the inductor current. The result is an output voltage higher than the input.

LTC3124

The typical application circuit Linear Technology's LTC3124 shown in Fig. 7-11 employs an external resistive voltage divider from V_{OUT} to FB to SGND to program the output from 2.5V to 15V. When set for a 12V output, it can deliver up to 1.5A continuously from a 5V input. Its 2.5A per phase current limit, along with the ability to program output voltages up to 15V make it suitable for a variety of applications.

Use of two phases equally spaced 180 deg. apart, doubles output ripple frequency, and significantly reduces output capacitor ripple current. Although this

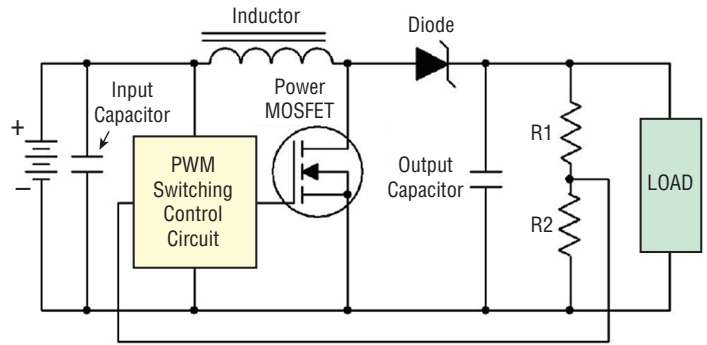

7-10. Basic non-isolated switch-mode inductive-boost dc-dc converter.

architecture requires two inductors, rather than a single inductor, it has several important advantages:

- Substantially lower peak inductor current allows the use of smaller, lower-cost inductors.
- Significantly reduced output ripple current minimizes output capacitance requirement.
- Higher-frequency output ripple is easier to filter for low-noise applications.
- Input ripple current is also reduced for lower noise on V_{IN}.

With two-phase operation, one phase always delivers current to the load whenever V_{IN} is greater than one-half V_{OUT} (for duty cycles less than 50%). As the duty cycle decreases further, load current delivery between the two phases begin to overlap, occurring simultaneously for a growing portion of each phase as the duty cycle approaches zero. Compared with a single-phase converter, this significantly reduces both the output ripple current

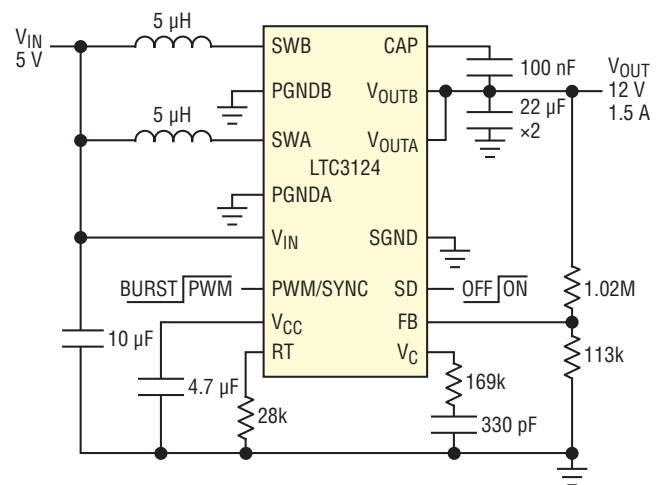

7-11. LTC3124 application circuit employs an external resistive voltage divider from V_{OUT} to FB to SGND to program the output from 2.5V to 15V.

and the peak current in each inductor.

The LTC3124 provides an advantage for battery-powered systems, it can start up from inputs as low as 1.8V and continue to operate from inputs as low as 0.5V, while producing output voltages greater than 2.5V. This extends operating times by maximizing the amount of energy extracted from the input source. The limiting factors for the application are the ability of the power source to supply sufficient power to the output at the low input voltage, and the maximum duty cycle, which is clamped at 94%. At low input voltages, small voltage drops due to series resistance become critical and limit the converter's power delivery.

Even if the input voltage exceeds the output voltage, the IC will regulate the output, enabling compatibility with any battery chemistry. The LTC3124 is an ideal solution for boost applications requiring outputs up to 15V where high efficiency, small size and high reliability are defining factors.

The LTC3110 from Linear Technology is a 2A buck-boost DC/DC regulator/charger combination with pin-selectable operation modes for charging and system backup (Fig. 7-12). This bidirectional, programmable input current buck-boost supercapacitor charger provides active charge balancing for 1- or 2-series supercapacitors. Its proprietary low noise buck-boost topology does the work of two separate switching regulators, saving size, cost and complexity.

LTC3110

The LTC3110 from Linear Technology is a 2A buck-boost DC/DC regulator/charger combination with pin-selectable operation modes for charging and system backup (Fig. 7-12). This bidirectional, programmable input current buck-boost supercapacitor charger provides active charge balancing for 1- or 2-series supercapacitors. Its proprietary low noise buck-boost topology does the work of two separate switching regulators, saving size, cost and complexity.

Bidirectional refers to the dc current flow related to VSYS, the power-supply pin for system backup output voltage and charge

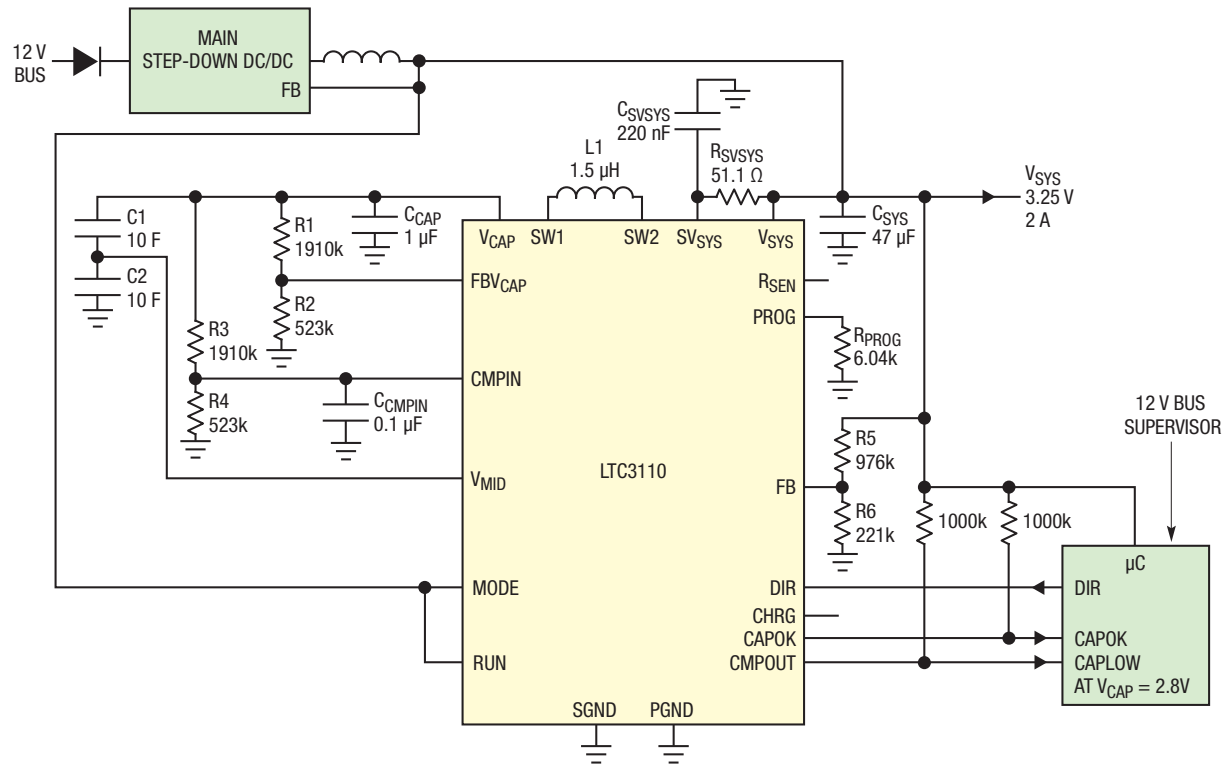

7-12. The LTC3110 is a 2A buck-boost dc/dc regulator/charger combination with pin-selectable operation modes for charging and system backup.

current input voltage. In one direction, the LTC3110 operates as a buck-boost regulator taking current out from the supercapacitor and providing a regulated voltage to the load at the VSYS pin. In the other direction, the sign

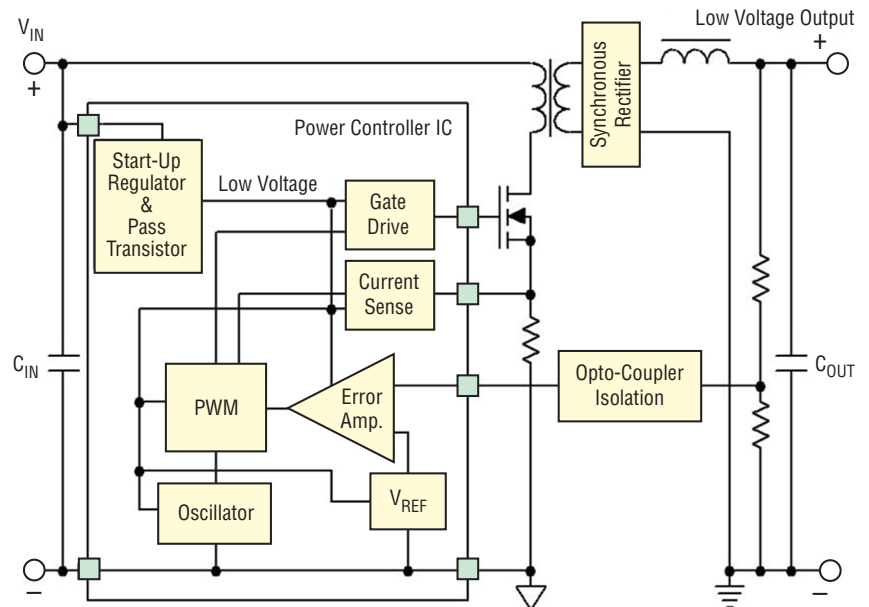

7-13. Basic forward converter can operate as a step-up or step-down converter. Theoretically, it should use an “ideal” transformer with no leakage fluxes, zero magnetizing current, and no losses.

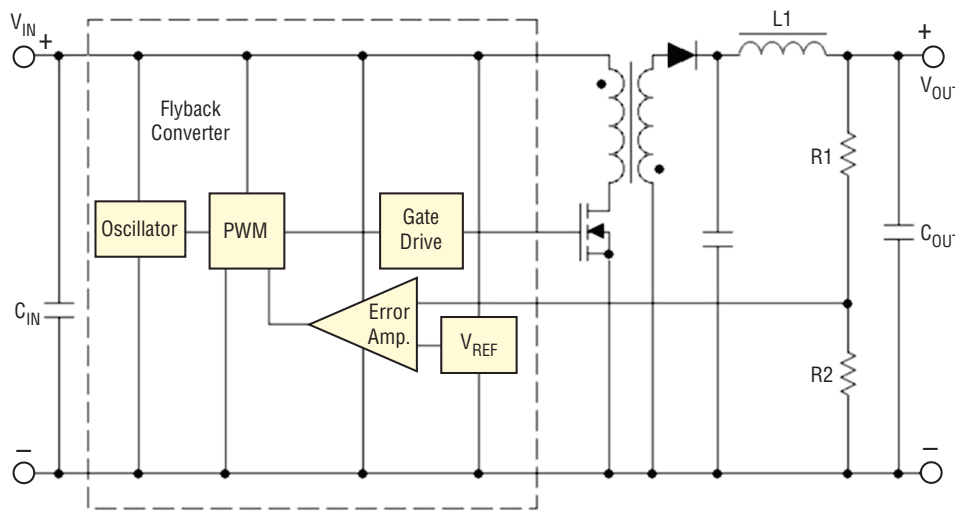

7-14. Basic flyback converter's transformer usually has an air gap, enabling it to store energy during the on-time and deliver the energy to the diode during off-time.

of the current flow reverses and an accurately limited current flows from the system rail back to charge the supercapacitor. If VSYS drops due to a power loss, it can switch direction autonomously to stabilize the system voltage by delivering current from the supercapacitor into VSYS.

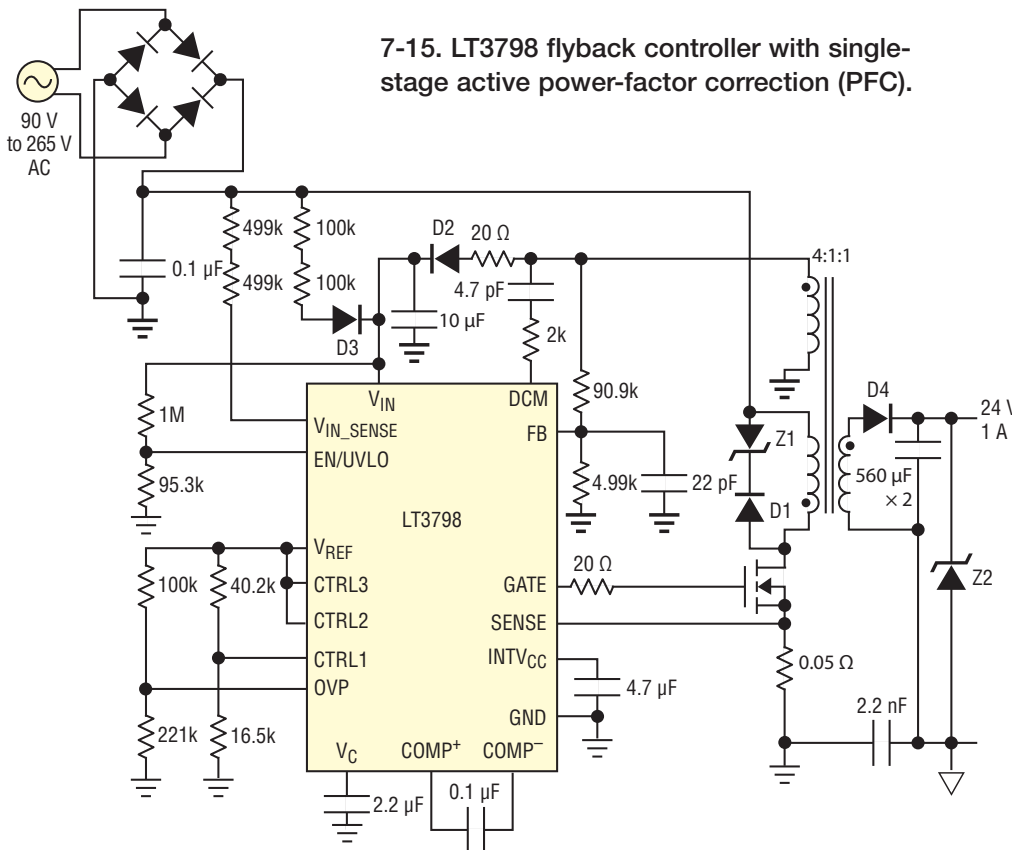

7-15. LT3798 flyback controller with single-stage active power-factor correction (PFC).

The LTC3110's 0.1V to 5.5V capacitor/battery voltage and 1.8V to 5.25V system backup voltage ranges make it well-suited to a wide variety of backup applications using supercapacitors or batteries, for example:

- It integrates all the functionality required to exploit the benefits of supercapacitors, charging, balancing and backup.
- An Input current limit with $\pm 2\%$ accuracy eliminates external components, lowers IQ and allows it to utilize full capability of power source without exceeding safety limits.
- Input power sharing enables LTC3110 and other dc/dc converters or loads to share the same power source with minimal derating/margin.
- An active balancer synchronously shuttles charge between the capacitors, eliminating external ballast resistors and their power losses, resulting in fewer recharge cycles and faster charging.
- It can autonomously transition from charge to backup mode or switch modes based on an external command.

In Fig. 7-13, the PWM control turns the MOSFET on and off. Without feedback, the PWM duty cycle determines the output voltage, which is twice the input for a 50% duty cycle. Stepping up the voltage by a factor of two causes the input current to be twice the output current. In a real circuit with losses, the input current is slightly higher.

Its advantages are simplicity, low cost, and the ability to step-up the output without a transformer. Disadvantages are a limited power range and a relatively high output ripple due to the off-time energy coming from the output capacitor.

Inductor selection is a critical part of this boost circuit design because the inductance value affects input and output ripple voltages and currents. An induc-

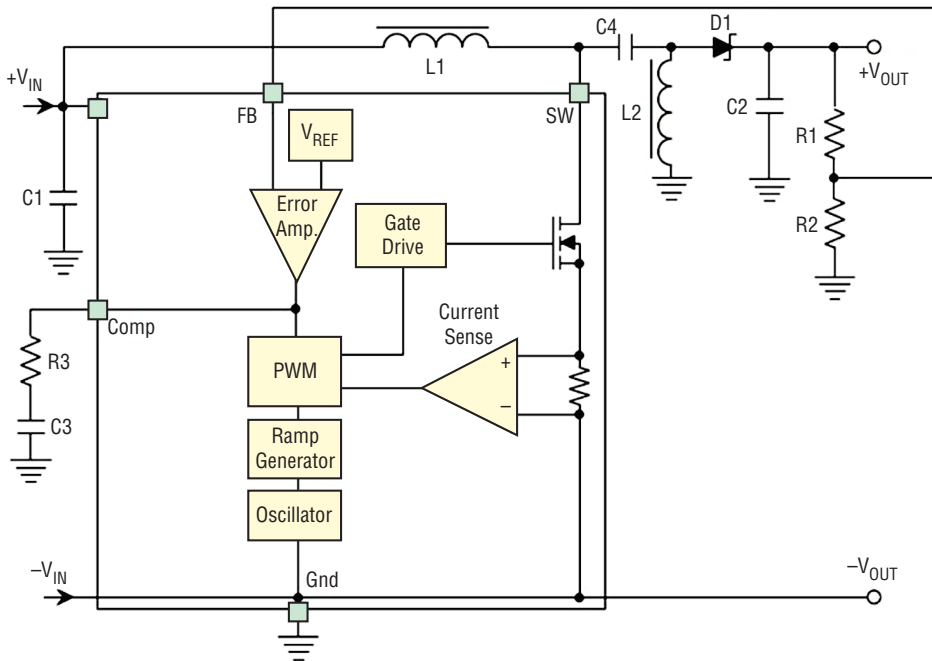

7-16. The two inductors in the basic SEPIC converter can be wound on the same core because the same voltages are applied to them throughout the switching cycle.

tor with low series resistance provides optimal power conversion efficiency. Choose the inductor's saturation current rating so that it is above the steady-state peak inductor current of the application.

To ensure stability for duty cycles above 50%, the inductor requires a minimum value determined by the minimum input voltage and maximum output voltage. This depends on the switching frequency, duty cycle, and on-resistance of the power MOSFET.

Forward converter topology (Fig. 7-13) is essentially an isolated version of the buck converter. Use of a transformer allows the forward converter to be either a step-up or step-down converter, although the most common

application is step-down. The main advantages of the forward topology are its simplicity and flexibility. Another transformer-isolated topology, the simplified flyback converter (Fig. 7-14) operates in the indirect conversion mode. Flyback topology is one of the most common and cost-effective means for generating moderate levels of isolated power in ac-dc converters. It has greater flexibility because it can easily generate multiple output voltages by adding additional secondary transformer windings. A disadvantage is that regulation and output ripple are not as tightly controlled as in some of the other topologies and the stresses on the power switch are higher.

LT3798

Linear Technology's LT3798 is an isolated flyback controller with single-stage active power-factor correction (PFC). Efficiencies greater than 86% can be achieved with output power levels up to 100W. Depending on the choice of external components, it can operate over a 90VAC to 277VAC input range, and can easily be scaled higher or lower. Furthermore, the LT3798 can be

designed into high input voltage dc applications, making it suited for industrial, EV/EHV automotive, mining, and medical applications.

Figure 7-15 shows a typical application for the LT3798. This IC is a current mode switching controller intended specifically for generating a constant current/constant voltage supply with an isolated flyback topology. To maintain regulation, this topology usually uses output voltage and current feedback from the isolated secondary side of the output transformer to VIN. Typically, this requires an opto-isolator. Instead, the LT3798 uses the external MOSFET's peak current derived from a sense

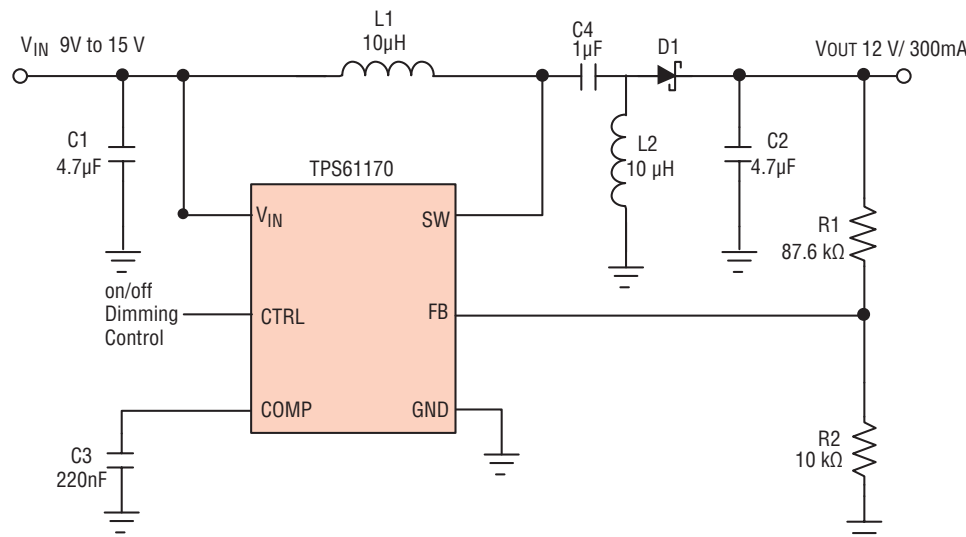

7-17. TPS61170 configured as a SEPIC converter.

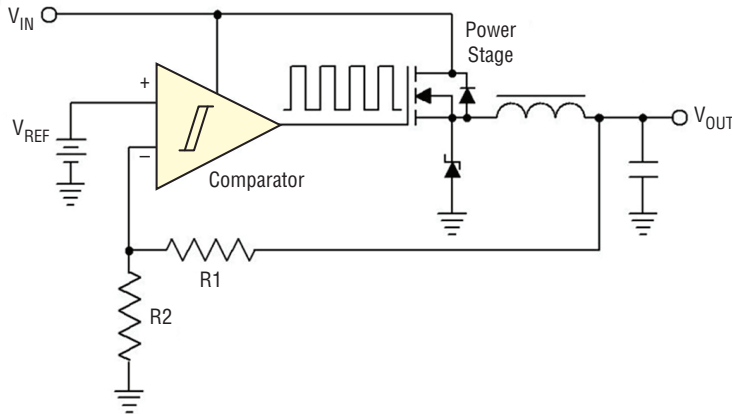

7-18. Basic hysteretic regulator represents the Fastest dc-dc converter control technique.

resistor to determine the flyback converter's output current, without requiring an optocoupler.

As shown in Fig. 7-15, the output transformer has three windings, including the output. The external MOSFET's drain connects to one of the primary windings. The transformer's third winding senses the output voltage and also supplies power for steady-state operation. The V_{IN} pin supplies power to an internal LDO that generates 10V at the $INTVCC$ pin. Internal control circuitry consists of two error amplifiers, minimum circuit, multiplier, transmission gate, current comparator, low output current oscillator, and master latch. Also, a sample-and-hold circuit monitors the third winding's output voltage. A comparator detects the discontinuous conduction mode (DCM) with a capacitor and series resistor connected to

the third winding.

During a typical cycle, the gate driver turns on the external MOSFET so that a current flows in the primary winding. This current increases at a rate proportional to the input voltage and inversely proportional to the transformer's magnetizing inductance. The control loop determines the maximum current and a comparator turns off the switch when it reaches that current. When the switch turns off, the energy in the transformer flows out the secondary winding through the output diode, D1. This current decreases at a rate proportional to the output voltage. When the current decreases to zero, the output diode turns off and voltage across the secondary winding starts to oscillate from the parasitic capacitance and the magnetizing inductance of the transformer.

All windings have the same voltage across them, so the third winding rings, too. The capacitor connected to the DCM pin trips the comparator, which serves as a dv/dt detector, when ringing occurs. This timing information is used to calculate the output current. The dv/dt detector waits for the ringing waveform to reach its minimum value and then the switch turns on. This switching behavior is similar to zero volt switching and minimizes the amount of energy lost when the switch is turned on, improving efficiency as much as 5%. This IC operates on the edge of continuous and discontinuous conduction modes, which is called the critical conduction mode (or boundary conduction mode). Critical conduction mode operation enables use of a smaller transformer than continuous conduction mode designs.

SEPIC

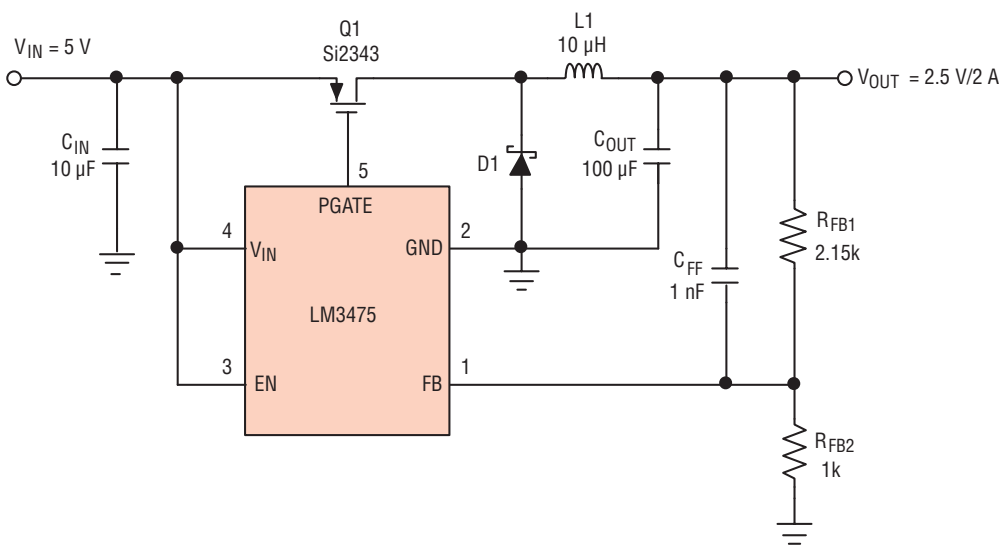

7-19. LM3475 is a buck (step-down) dc-dc controller that uses a hysteretic control architecture, which results in Pulse Frequency Modulated (PFM) regulation.

The single-ended primary-inductance converter (SEPIC) is a dc/dc-converter topology that provides a positive regulated output voltage from an input voltage that varies from above to below the output voltage. The simplified SEPIC converter shown in Fig. 7-16 uses two inductors, L1 and L2, which can be wound on the same core because the same voltages are applied to them throughout the switching cycle. Using a coupled inductor takes up less space on the p.c. board and tends to be lower-cost than two separate inductors. The capacitor C4 isolates the input from the output and provides protection against a shorted load.

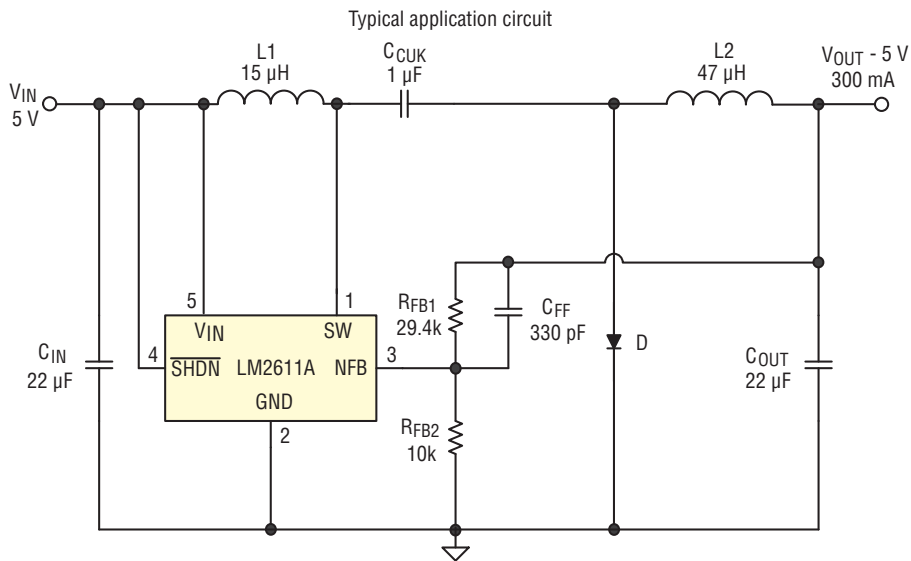

7-20. LM2611 configured as a Cuk converter

The IC regulates the output with current mode PWM control that turns on the power MOSFET Q1 at the beginning of each switching cycle. The input voltage is applied across the inductor and stores the energy as inductor current ramps up. During this portion of the switching cycle, the load current is provided by the output capacitor. When the inductor current rises to the threshold set by the error amplifier output, the power switch turns off and the external Schottky diode is forward biased. The inductor transfers stored energy to replenish the output capacitor and supply the load current. This operation repeats in every switching cycle. The duty cycle of the converter is determined by the PWM control comparator, which compares the error amplifier output and the current signal.

A ramp signal from the oscillator is added to the current ramp. This slope compensation is to avoid sub-harmonic oscillation that is intrinsic to the current mode control at duty cycle higher than 50%. The feedback loop regulates the FB pin to a reference voltage through an error amplifier. The output of the error amplifier is connected to the COMP pin. An external RC compensation network is connected to the COMP pin to optimize the feedback loop for stability and transient response.

TPS61170

The TPS61170 is a monolithic, high-voltage switching regulator from Texas Instruments with an integrated 1.2A, 40V power MOSFET. The device can be configured in several standard regulator topologies, including boost and SEPIC. Figure 7-17 shows the SEPIC configuration. The device has a wide input-voltage range to support applications with input voltage from batteries or

regulated 5V, 12V power rails.

The IC integrates a 40 V low-side FET for providing output voltages up to 38 V. The device regulates the output with current mode PWM (pulse width modulation) control. The switching frequency of the PWM is fixed at 1.2 MHz (typical). The PWM control circuitry turns on the switch at the beginning of each switching cycle. The input voltage is applied across the inductor and stores the energy as the inductor current ramps up. During this portion of the switching cycle, the load current is provided by the output capacitor. When the inductor current rises to the threshold set by the error amplifier output, the power switch turns off and the external Schottky diode is forward biased. The

inductor transfers stored energy to replenish the output capacitor and supply the load current. This operation repeats each switching cycle. As shown in the block diagram, the duty cycle of the converter is determined by the PWM control comparator which compares the error amplifier output and the current signal.

The TPS61170 operates at a 1.2-MHz switching frequency, allowing the use of low-profile inductors and low-value ceramic input and output capacitors. It has built-in protection, including overcurrent limit, soft start and thermal shutdown.

Hysteretic Converter

The basic hysteretic regulator shown in Fig. 7-18 is a type of switching regulator that does not employ a PWM. It consists of a comparator with input hysteresis that compares the output feedback voltage with a reference voltage. When the feedback voltage exceeds the reference voltage, the comparator output goes low, turning off the buck-switch MOSFET. The switch remains off until the feedback voltage falls below the reference hysteresis voltage. Then, the comparator output goes high, turning on the switch and allowing the output voltage to rise again.

The basic hysteretic converter consists of an Error Comparator, control logic, and internal reference. The output usually drives a synchronous rectifier, which can be internal or external. A portion of the output voltage is fed back to the Error Comparator, which compares it with the reference voltage. If the output tends to go low relative to the reference voltage, the output capacitor charges up until it reaches equilibrium with the reference voltage. The comparator then turns on the synchronous

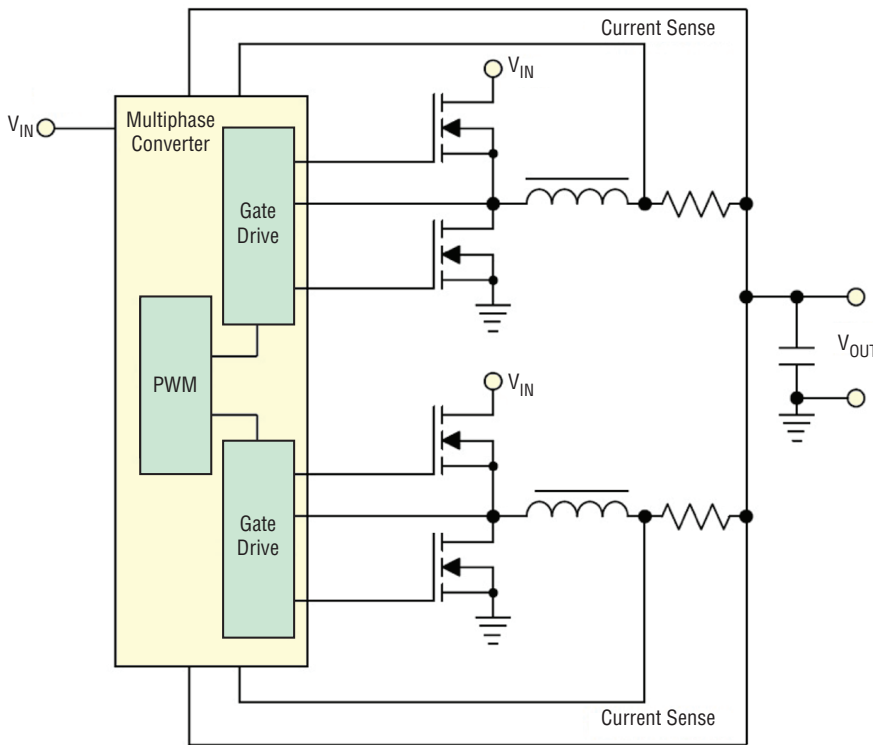

7-21. Basic multiphase converter has two phases that are interleaved, which reduces ripple currents at the input and output.

rectifier. When the synchronous rectifier is on, the output voltage drops low enough to overcome the comparator's hysteresis, at which time the synchronous rectifier turns off, starting a new cycle.

There is no voltage-error amplifier in the hysteretic regulator, so its response to any change in the load current or the input voltage is virtually instantaneous. Therefore, the hysteretic regulator represents the fastest possible dc-dc converter control technique. A disadvantage of the conventional hysteretic regulator is that its frequency varies proportionally with the output capacitor's ESR. Since the initial value is often poorly controlled, and the ESR of electrolytic capacitors also changes with temperature and age, practical ESR variations can easily lead to frequency variations in the order of one to three. However, there is a modification of the hysteretic topology that eliminates the dependence of the operating frequency on the ESR.

LM3475

The LM3475 is a buck (step-down) dc-dc controller that uses a hysteretic control architecture, which results in Pulse Frequency Modulated (PFM) regulation (Fig. 7-19). The hysteretic control scheme does not utilize an internal oscillator. Switching frequency depends on external components and operating conditions. Oper-

ating frequency decreases at light loads, resulting in excellent efficiency compared to PWM architectures. Because switching is directly controlled by the output conditions, hysteretic control provides exceptional load transient response.

The LM3475 uses a comparator-based voltage control loop. The voltage on the feedback pin is compared to an 0.8V reference with 21mV of hysteresis. When the FB input to the comparator falls below the reference voltage, the output of the comparator goes low. This results in the driver output, PGATE, pulling the gate of the PFET low and turning on the PFET.

With the PFET on, the input supply charges C_{OUT} and supplies current to the load through the PFET and the inductor. Current through the inductor ramps up linearly, and the output voltage increases. As the FB voltage reaches the upper threshold (reference voltage plus hysteresis) the output of the comparator goes high, and the PGATE turns the PFET off. When the PFET turns off, the catch diode turns on, and the current through the inductor ramps down. As the output voltage falls below the reference voltage, the cycle repeats.

Cuk Converter

The Cuk converter is a dc-dc converter whose output voltage magnitude can be either greater than or less than the input voltage. It is essentially a boost converter followed by a buck converter with a capacitor to couple the energy. It is an inverting converter, so the output voltage is negative with respect to the input voltage. The non-isolated Cuk converter can only have opposite

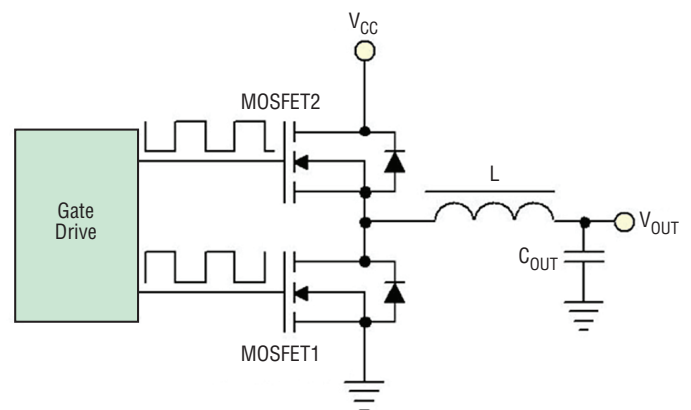

7-22. Synchronous rectifier is more efficient than a diode rectifier.

polarity between input and output. It uses a capacitor as its main energy-storage component, unlike most other types of converters that use an inductor.

As with other converters (buck converter, boost converter, buck-boost converter), the Cuk converter can either operate in continuous or discontinuous current mode. However, unlike these converters, it can also operate in discontinuous voltage mode (the voltage across the capacitor drops to zero during the commutation cycle).

The LM2611 from Texas Instruments is a Cuk converter that consists of a current mode controller with an integrated primary switch and integrated current sensing circuitry (Fig. 7-20). The feedback is connected to the internal error amplifier and it uses type II/III internal compensation. A ramp generator provides some slope compensation to the system. $\overline{\text{SHDN}}$ pin is a logic input designed to shut down the converter.

A current mode, fixed frequency PWM switching regulator the LM2611 has a -1.23V reference that makes it ideal for use in a Cuk converter. The Cuk converter inverts the input and can step up or step down the absolute value. Using inductors on both the input and output, the Cuk converter produces very little input and output current ripple. This is a significant advantage over other inverting topologies such as the buck-boost and flyback.

Multiphase Converter

As current requirements increase, so does the need for increasing the number of phases in the converter.

Single-phase buck controllers are fine for low-voltage applications with currents of up to about 25 A, however power dissipation and efficiency are an issue at higher currents. One approach for higher current loads is the multiphase buck controller. Their performance makes them ideal for powering personal electronics, portable industrial, solid state drive, small-cell applications, FPGAs, and microprocessors.

The two-phase circuit shown in Fig. 7-21 has interleaved phases, which reduces ripple currents at the input and output. It also reduces hot spots on a printed circuit

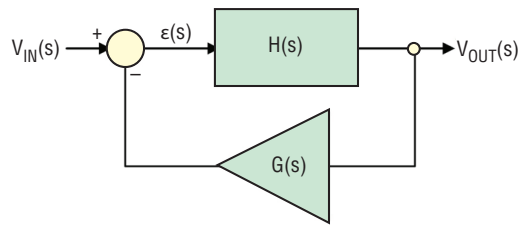

7-23. Typical switch-mode power supply model with negative feedback employs a compensation block, $G(s)$, and $H(s)$, the open-loop gain. $V_{IN}(s)$ is the input and $V_{OUT}(s)$ is the output.

board or a particular component. A two-phase buck converter reduces RMS current power dissipation in the MOSFETs and inductors by half. Interleaving also reduces transitional losses.

Multiphase cells operate at a common frequency, but are phase shifted so that conversion switching occurs at regular intervals controlled by a common control chip. The control chip staggers the switching time of each converter so that the phase angle between

each converter switching is 360 deg./n , where n is the number of converter phases. The outputs of the converters are paralleled so that the effective output ripple frequency is $n \times f$, where f is the operating frequency of each converter. This provides better dynamic performance and significantly less decoupling capacitance than a single-phase system.

Current sharing among the multiphase cells is necessary so that one does not hog too much current. Ideally, each multiphase cell should consume the same amount of current. To achieve equal current sharing, the output current for each cell must be monitored and controlled.

The multiphase approach also offers packaging advantages. Each converter delivers $1/n$ of the total output power, reducing the physical size and value of the magnetics employed in each phase. Also, the power semiconductors in each phase only need to handle $1/n$ of the total power. This spreads the internal power dissipation over multiple power devices, eliminating the concentrated heat sources and possibly the need for a heat sink. Even though this uses more components, its cost tradeoffs can be favorable.

Multiphase converters have important advantages:

- Reduced RMS current in the input filter capacitor, allows use of a smaller and less expensive types
- Distributed heat dissipation, reduces the hot-spot temperature, increasing reliability
- Higher total power capability
- Increased equivalent frequency without increased switching losses, which allows use of smaller equivalent inductances that shorten load transient time
- Reduced ripple current in the

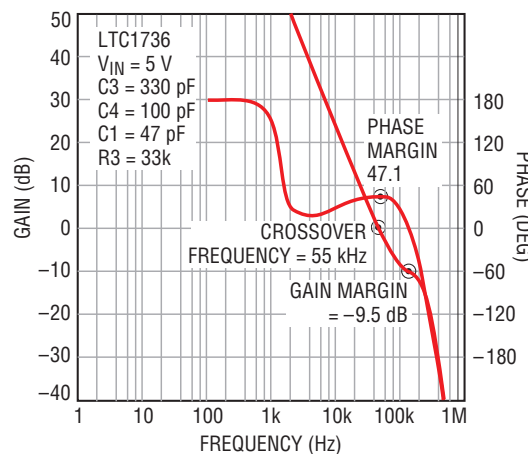

7-24. Typical Bode plot for a switch-mode voltage regulator IC shows crossover frequency, gain, and phase margin.

output capacitor reduces the output ripple voltage and allows use of smaller and less expensive output capacitors

- Excellent load transient response over the entire load range

Multiphase converters also have some disadvantages that should be considered when choosing the number of phases, such as:

- The need for more switches and output inductors than in a single-phase design, which leads to a higher system cost than a single-phase solution, at least below a certain power level
- More complex control
- The possibility of uneven current sharing among the phases
- Added circuit layout complexity

Synchronous Rectification

Efficiency is an important criterion in designing dc-dc converters, which means power losses must be minimized. These losses are caused by the power switch, magnetic elements, and the output rectifier. Reduction in power switch and magnetics losses require components that can operate efficiently at high switching frequencies. Output rectifiers can use Schottky diodes, but synchronous rectification (Fig. 7-22) consisting of power MOSFETs can provide higher efficiency.

MOSFETs exhibit lower forward conduction losses than Schottky diodes. Unlike conventional diodes that are self-commutating, the MOSFETs turn on and off by means of a gate control signal synchronized with converter operation. The major disadvantage of synchronous rectification is the additional complexity and cost associated with the MOSFET devices and associated control electronics. At low output voltages, however, the resulting increase in efficiency more than offsets the cost disadvantage in many applications.

Voltage Regulator Compensation

Switched-mode power supplies use negative feedback to regulate their output to a desired value. The optimum SMPS control system using negative feedback should feature speed, precision, and an oscillation-free response. One way to accomplish this is to limit the frequency range within which the SMPS reacts. To be stable, the frequency range, or bandwidth, should correspond to a frequency where the closed-loop transmission path from the input to the output drops by 3 dB (called the crossover frequency). It is mandatory to limit

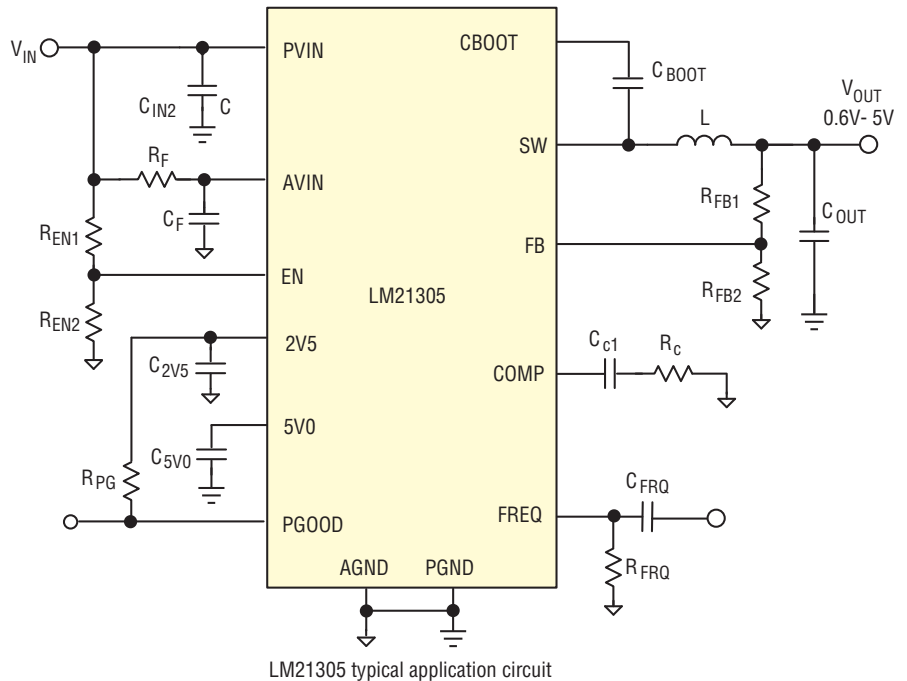

LM21305 typical application circuit

7-25. The LM21305 is a switch-mode regulator IC that employs a single compensation node that requires compensation components RC and CC1 connected between the COMP pin and AGND.

the bandwidth to what your application actually requires. Adopting too wide a bandwidth affects the system's noise immunity and too low a bandwidth results in poor transient response. You can limit the bandwidth of an SMPS control system by shaping its loop gain curve (V_{OUT}/V_{IN}) using the compensator block, $G(s)$ shown in Fig. 7-23. This block will ensure that after a certain frequency the loop gain magnitude drops and passes below 1 or 0 dB.

Also, to obtain a response converging toward a stable state we need to ensure that the phase where the loop gain magnitude is 1 is less than -180 deg. To make sure we stay away from the -180 deg. at the crossover frequency, the compensator $G(s)$ must tailor the loop response at the selected crossover frequency to build the necessary phase margin. The appropriate phase margin ensures that despite external perturbations or unavoidable production spreads, changes in the loop gain will not put the system's stability in jeopardy. The phase margin also impacts the transient response of the system. Therefore, the compensator, $G(s)$ must provide the desired gain and phase characteristics.

Using a network analyzer you can determine stability margins by measuring the gain and phase of the control loop, and then observe the resulting Bode plot (Fig. 7-24) that is a graph of the gain and phase versus frequency of a power supply. A 60-deg. phase margin is preferred, but 45 deg. is usually acceptable. A gain mar-

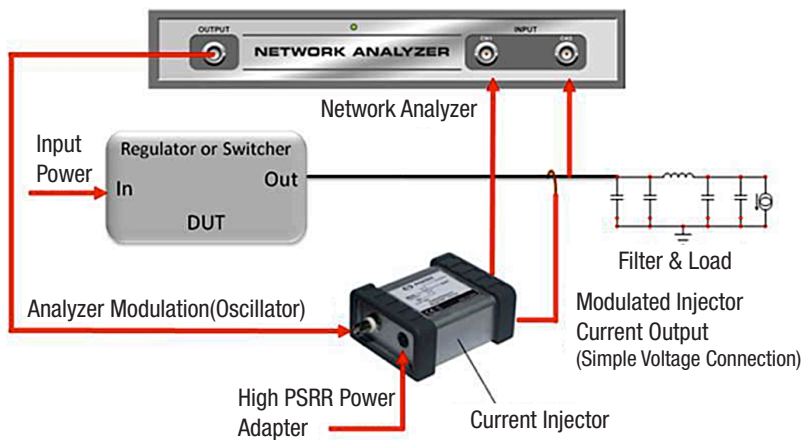

7-26. Non-accessible output impedance measurements (Picotest).

gain of -10dB is usually considered acceptable. Gain and phase margin are important because actual component values may vary over temperature. Thus, component values may differ from unit-to-unit in production, causing the control loop's voltage gain and phase to vary accordingly. Plus, component values may vary over time, and cause instability.

If component values cause the phase to go to zero at the crossover frequency, the regulator becomes unstable and oscillates. The goal of compensation is to provide the best gain and phase margins with the highest possible crossover frequency. A high crossover frequency provides a quick response to load current changes, whereas high gain at low frequencies produces fast settling of the output voltage. Component values and $V_{\text{OUT}}/V_{\text{IN}}$ variations can force a trade-off between high crossover frequency and high stability margins.

Determining the compensation for a power supply isn't always easy because a Bode plot assessment is not feasible when there is no feedback loop access to the

part. In other cases, the feedback loop is difficult to access because the hardware is integrated or would require cutting a PCB trace. In other cases, the devices either contain multiple control loops, with only one of them being accessible, or the order of the control loop is higher than second order, in which case the Bode plot is a poor predictor of relative stability. A further complication is that in many portable electronics, such as cell phones and tablets, the circuitry is very small and densely populated leaving little in the way of access to the control loop elements.

In the above cases the only way to verify stability is with non-invasive stability margin (NISM) assessment. It is derived from easily accessible output impedance measurements. The mathematical relationship that allows the precise determination of the control loop stability from output impedance data was developed by Picotest and incorporated into the OMICRON Lab Bode 100 Vector Network Analyzer (VNA) software. Figure 7-26 shows the test setup for this measurement.

One of the earliest compensation techniques provided a voltage regulator with external nodes so the designer could insert compensation components. Determining compensation component values involved an analysis of the regulator IC and its external components. After determining the required compensation, the designer modeled or measured the regulator circuit with the compensation components installed. This process usually required several iterations before obtaining the desired results.

Proper implementation of a compensation network requires engineers with special tools, skills and experience. If the circuit was modeled and not measured, the designer had to eventually insert the actual compensation components to measure supply performance. Modeling was only as good as the designer's knowledge of the components and parasitics. The model might have been incomplete or differed from the actual circuit, so compensation had to be verified by measurement of the actual circuit. Invariably, reworking was necessary because of possible errors associated with changing components. Reworking could also change supply performance and damage circuits powered by the regulator.

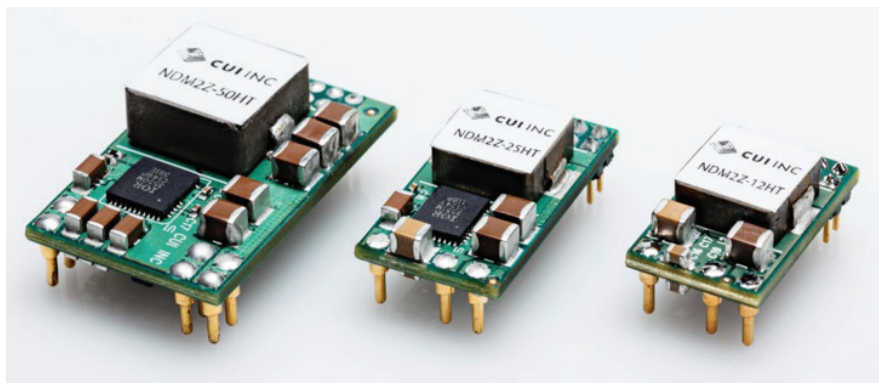

7-27. CUI's NDM2Z power-supply family employs auto compensation that allows it to dynamically set optimum stability and transient response.

Some regulator IC vendors included internal compensation components, so the design didn't need further analysis. However, the designer had to use external

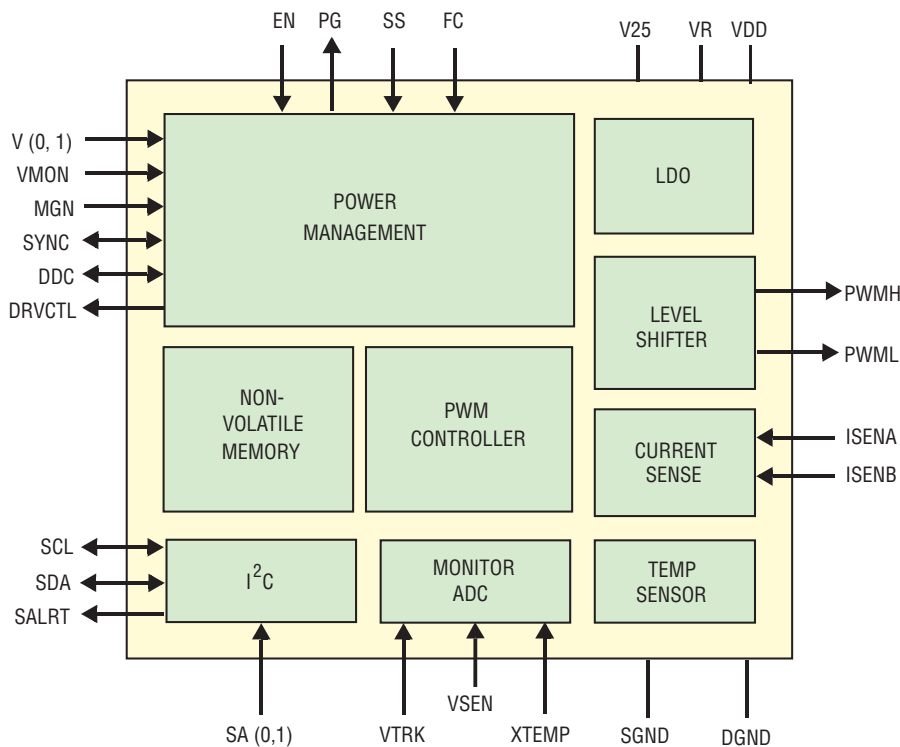

7-28. Intersil's ZL8101 IC block diagram shows the PWM outputs (PWML and PWML) that interface with an external driver like the ZL1505.

vendor-specified components.

A single compensation node was the next stage in this evolution. An example of this is Texas Instruments' LM21305 switch-mode regulator IC, as shown in Fig. 7-25. The LM21305 typically requires only a single resistor and capacitor for compensation. However, sometimes it required an additional capacitor.

Auto Compensation

To eliminate the problems associated with manual determination of power supply compensation two companies developed the technology for automatic compensation. This resulted in mixed signal regulator IC designs employing automatic compensation. This relieved the designer of the need for special tools, knowledge or experience to optimize performance. Automatic compensation sets the output characteristics so that changes due to component tolerances, ageing, temperature, input voltage and other factors do not affect performance.

CUI's NDM2Z family (Fig. 7-27) of digital point-of-load power supplies incorporate auto compensation using the Intersil/Zilker ZL8101M regulator IC. Auto compensation bypasses the traditional practice of building in margins to account for component variations, which can lead to higher component costs and longer design cycles.

The 50A NDM2Z supplies deliver 91% efficiency with 12 Vdc input and 1.0 Vdc output at 50% load. These supplies all have a 4.5 to 14 Vdc input range and a programmable output of 0.6 to 5.0 Vdc in the 12A version and 0.6 to 3.3 Vdc in the 25A and 50A versions.

Module features include active current sharing, voltage sequencing, voltage tracking, synchronization and phase spreading, programmable soft start and stop, as well as a host of monitoring capabilities. CUI's simple, easy-to-use GUI aids these designs.

ZL8101

The NMD2Z uses an Intersil/Zilker ZL8101, voltage-mode, synchronous buck controller with a constant frequency pulse width modulator (PWM). This third-generation digital controller uses a dedicated, optimized, state machine for generating precise PWM pulses and a proprietary microcontroller used for setup, house-keeping, and optimization (Fig. 7-28). It requires external drivers, power MOSFETs, capacitors, and inductors. Integrated sub-regulation allows operation from a single 4.5V to 14V supply. Using simple pin connections or standard PMBus commands you can configure an extensive set of power management functions with Intersil's PowerNavigator GUI.

Initially, the ZL8101's auto compensation measures the characteristics of the power train and determines the required compensation. The IC saves compensation values and uses them on subsequent inputs. Once enabled, the ZL8101 is ready to regulate power and perform power management tasks with no programming required. Advanced configuration options and real-time configuration changes are available via the I2C/SMBus interface. An on-chip non-volatile memory (NVM) saves configuration data.

You should choose the external power MOSFETs primarily on RDS(ON) and secondarily on total gate charge. The actual power converter's output current depends on the characteristics of the drivers and output MOSFETs.

Configurable circuit protection features continuously safeguard the IC and load from damage due to system faults. The ZL8101 continuously monitors input voltage, output voltage/current, internal temperature, and temperature of an external thermal diode. You can also set monitoring parameters for specific fault condition alerts.

A non-linear response (NLR) loop improves the re-

response time and reduces load transient output deviations. To optimize power converter efficiency, the ZL8101 monitors its operating conditions and continuously adjusts the turn-on and turn-off timing of the high-side and low-side power MOSFETs. Adaptive performance optimization algorithms such as dead-time control, diode emulation, and adaptive frequency provide greater efficiency improvement.

A Power-Good (PG) signal indicates the output voltage is within a specified tolerance of its target level and no fault condition exists. By default, the PG pin asserts if the output is within $-10\%/+15\%$ of the target voltage. You can change these limits and the polarity via the I2C/SMBus interface.

An internal phase-locked loop (PLL) serves as a clock for internal circuitry. You can drive the PLL from an external clock source connected to the SYNC pin. You can set the switching frequency from 200kHz to 1.33MHz.

A Windows-based GUI enables full configuration and monitoring capability via the I2C/SMBus interface.

CUI's NDM3Z-90 is a 90A module that has several features that enable high power conversion efficiency. Adaptive algorithms and cycle-by-cycle charge management improves the response time and reduces the output deviation as a result of load transients.

ZL8800

The NDM3Z uses the Intersil ZL8800 for auto compensation. It is a dual output or dual phase digital dc/dc controller. Each output can operate independently or be used together in a dual phase configuration for high current applications. The ZL8800 supports a wide range of output voltages (0.54V to 5.5V) operating from input voltages as low as 4.5V up to 14V. Figure 7-29 shows the two-phase configuration that employs external DRMOS power modules.

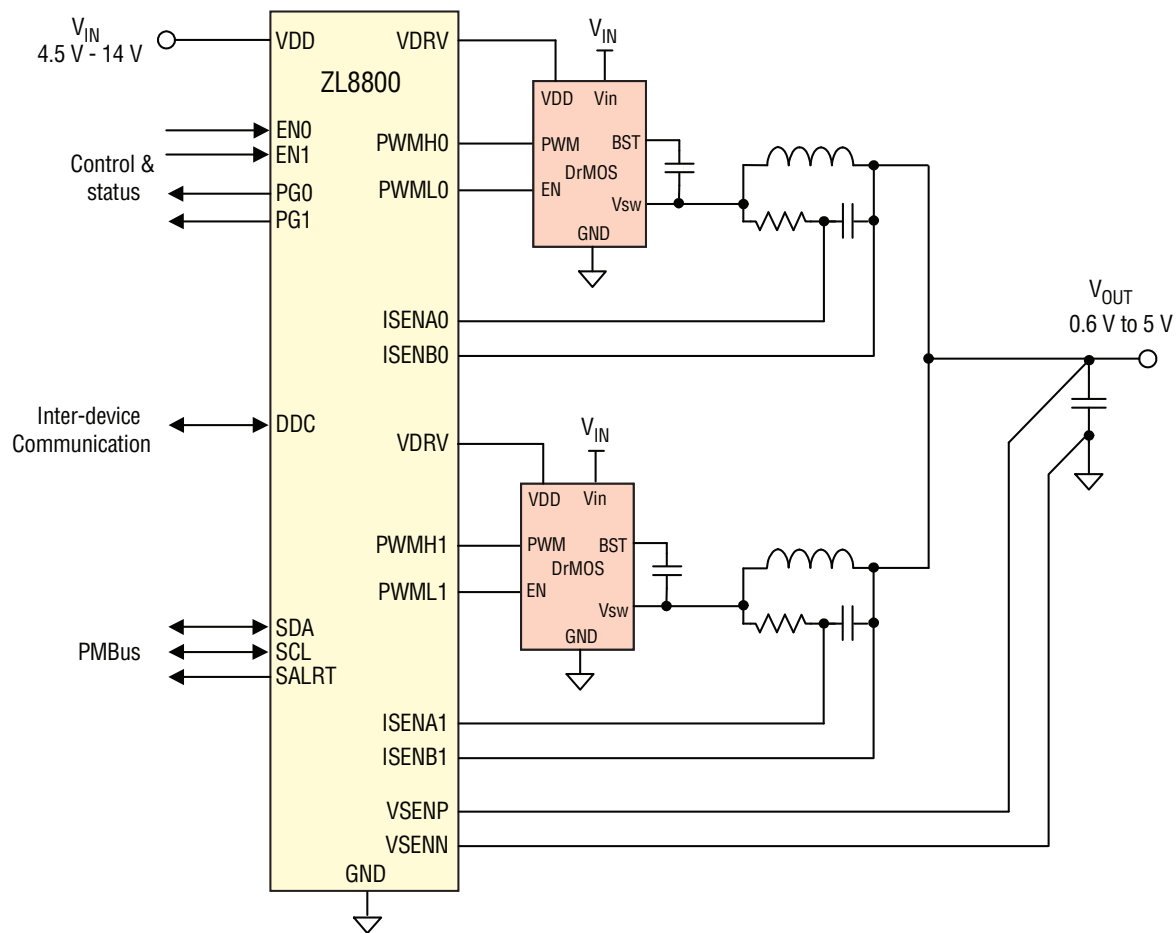

7-29. Intersil's ZL8800 configured as a two-phase converter

With the fully digital ChargeMode Control, the ZL8800 will respond to a transient load step within a single switching cycle. This unique compensation-free modulation technique allows designs to meet transient specifications with minimum output capacitance thus saving cost and board space.

Intersil's proprietary single wire DDC (Digital-DC) serial bus enables the ZL8800 to communicate between other Intersil ICs. By using the DDC, the ZL8800 achieves complex functions such as inter-IC phase current balancing, sequencing and fault spreading, eliminating complicated power supply managers with numerous external discrete components.

The ZL8800 features cycle-by-cycle output overcurrent protection. The input voltage, output voltages, and DrMOS/MOSFET driver supply voltages are under- and overvoltage protected. Two external and one internal temperature sensors are available for temperature monitoring, one of which is used for under and over-temperature protection. A snapshot parametric capture feature allows users to take a snapshot of operating and fault data during normal or fault conditions.

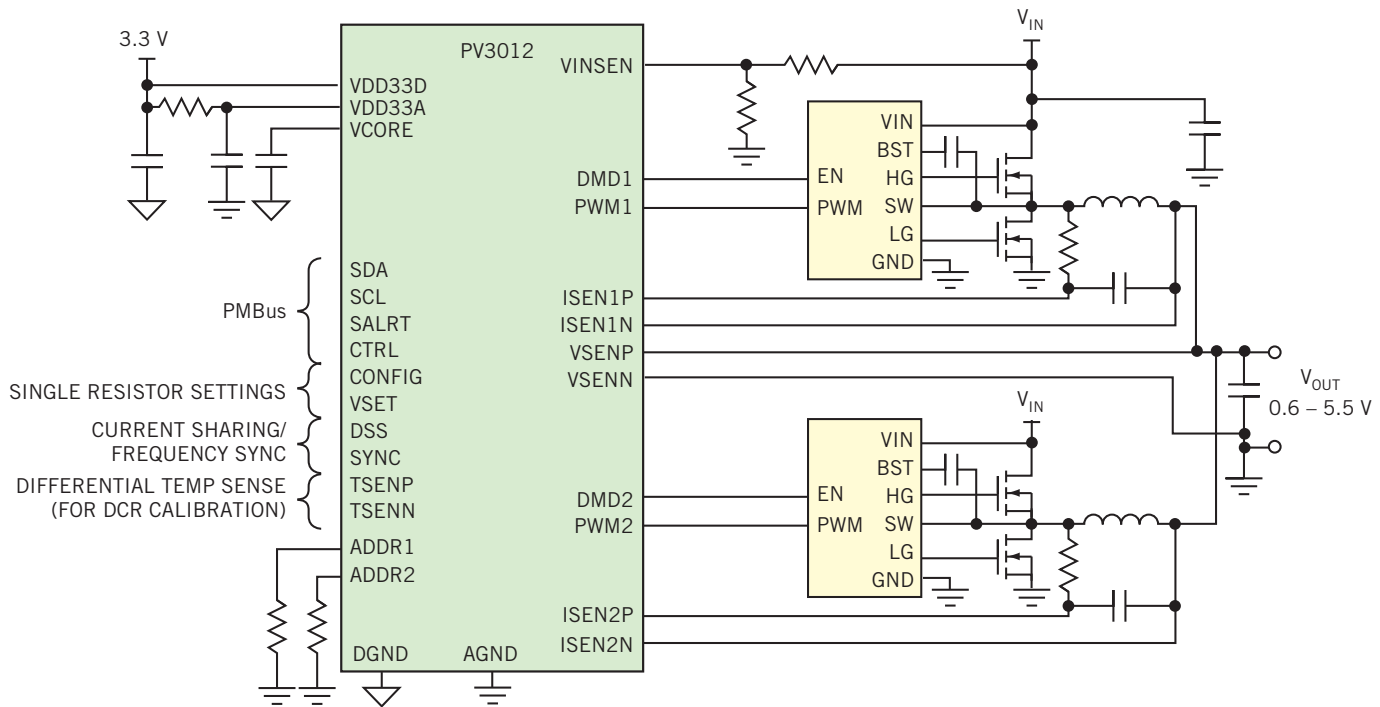

7-30. Powervation's PV3012 IC is a real-time auto compensation IC with a single output, dual- or single-phase digital synchronous buck controller for POL applications.

Integrated Low Dropout (LDO) regulators allow the ZL8800 to be operated from a single input supply eliminating the need for additional linear regulators. The LDO output can be used to power external drivers or DrMOS devices.

With full PMBus compliance, the ZL8800 is capable of measuring and reporting input voltage, input current, output voltage, output current as well as the device's internal temperature, external temperatures and an auxiliary voltage input.

This supply incorporates a wide range of configurable power management features that are simple to implement with a minimum of external components. Additionally, the supply has protection features that continuously safeguard the load from damage due to unexpected system faults.

The supply's standard configuration is suitable for a wide range of operation in terms of input voltage, output voltage, and load. The configuration is stored in an internal Non-Volatile Memory (NVM). All power-management functions can be reconfigured using the PMBus interface.

Powervation Auto Compensation

Bellnix Co. Ltd. (Japan) uses ROHM's PV3012 Powervation digital controller in its low-profile, 60 A dc/dc module. The BDP12-0.6S60R0 digital power module is a PMBus compliant, non-isolated step-down converter that

addresses the needs for small form-factor designs while providing high reliability and high performance. ROHM's PV3012 is a digital two-phase controller (Fig. 7-30).

The 60 A BDP uses, and parallel BDP module operation is supported via ROHM's DSS current sharing bus. This PMBus compliant module features precision measurement and telemetry reporting, a full line of programmable power-supply protection features, power good, and optional tracking function, all in a compact 32.8 mm × 23.0 mm ROHS compliant SMD package design.

ROHM's PV3012 Powervation digital controller is also used TDK-Lambda's iJB Series high-current digital POL modules use. The iJB series products support low-voltage, high-current operation while providing ±0.5% set-point accuracy over line, load, and temperature range. While the PMBus functionality of the module provides real-time telemetry of voltage, current, and temperature and enables full programmability of the dc/dc converter, the iJB series products also employ function setting pins, enabling them to be used in non-PMBus applications.

Using the Powervation intelligent auto-tuning technology, Auto-Control, the iJB POL modules bring better dynamic performance and system stability to the application. Auto-Control is a patented adaptive compensation technology that optimizes dynamic performance and system stability in real-time without requiring any

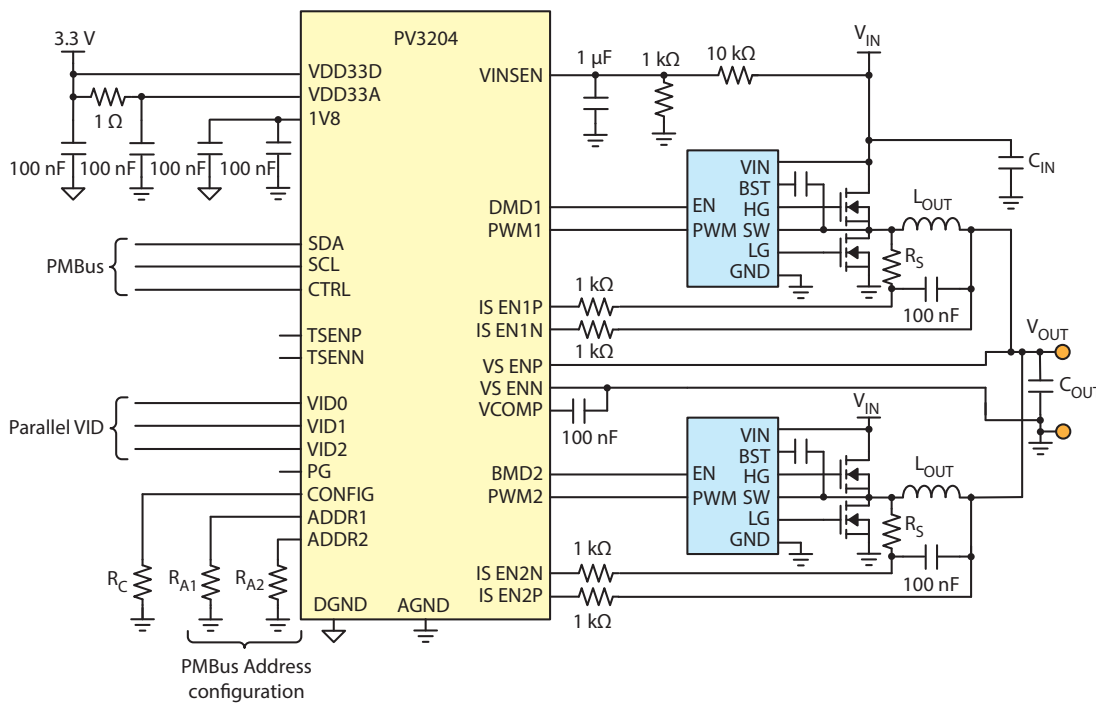

7-31. Powervation's PV3204 is a dual-phase digital synchronous buck controller with adaptive loop auto-compensation, for point-of-load (POL) applications.

noise injection or the drawbacks of periodic techniques. This is a key benefit for modules and other designs that drive unknown or variable output loads, and addresses the challenges of load parameter drift that occurs over temperature and time.

Another PV3012 digital controller user is Murata Power Solutions' the OKLF-T/25-W12N-C DC/DC module. It is a non-isolated, DC/DC converter delivering a maximum of 25 A at an output of 1.2 V, when operating up to 70°C with a 200 LFM airflow. The adjustable outputs provide precision regulation from 0.69 V to 3.63 V over a wide input range (6.5 V to 14 V).

Murata Power Solutions' OKLF 25 A module delivers ultra-fast load transient response, exceptional de-rating performance, and >90% typical efficiency in a high power density form-factor. The module is a complete, stand-alone power supply; with the use of the PV3012 digital control IC, it provides a full-line of protection features and precision set-point accuracy.

This POL converter delivers precision set-point accuracy of $\pm 0.5\%$ over line, load, and temperature range – far better than analog options. Additionally, this offering adds value by the use of space saving elevated inductors and Powervation's Auto-Control.

PV3204

One of the new Powervation products from ROHM that provide auto compensation is the PV3204, a dual phase digital synchronous buck controller with adap-

tive loop compensation, for point-of-load (POL) applications (Fig. 7-31). The output can supply 0.6 V to 5.5 V, and can be configured and controlled via PMBus or through programming stored in the non-volatile memory (NVM). Besides the SMBus interface, PV3204 provides a 3-bit parallel VID interface with a mapping from 0.85 V to 1.0 V in 25 mV steps, and 1.05 V.

PV3204

PV3204 uses the Powervation proprietary adaptive digital control loop, Auto-Control, a real-time adaptive loop

compensation technology for switching power converters that autonomously balances the trade-offs between dynamic performance and system stability. Auto-Control does away with complex calculations and setting optimum stability employed with traditional compensation techniques. Auto-Control adjusts P, I, and D coefficients each switching cycle to continuously achieve optimum stability over a wide range of disturbances. Auto-Control is embedded in the control architecture of the Powervation digital devices, and does not rely on injected noise of periodic calibrations. The continuous nature of Auto-Control allows it to manage changes in the system that occur in real-time, or slowly over time while the power supply is in use. This self-compensation occurs on a cycle-by-cycle basis, so Auto-Control is able to continuously adjust according to changes in temperature that occur while the power supply is in use, and accounts for other factors such as aging and drift.

This controller may be used in single- or dual-phase mode. When used in dual-phase mode, phases may be added or removed as the load varies, so that efficiency is maximized over the load range. Additionally, the outputs of the phases are interleaved so that the effective switching frequency at the output is doubled.

The digital functionality of this PMBus power converter controller allows system telemetry (remote measurement and reporting) of current, voltage, and temperature information.

Additionally, to maximize system performance and

reliability, the IC provides temperature correction/compensation of several parameters. 

Related Articles

1. Sam Davis, *Two-Phase, Synchronous Boost Regulator IC Delivers Up to 15V*, [powerelectronics.com](#), July 2014.
2. Sam Davis, *DC-DC Boost Converter Harvests Photovoltaic Energy*, [powerelectronics.com](#), January 2011.
3. Sam Davis, *42V Quad Monolithic Synchronous Step-Down Regulator*, [powerelectronics.com](#), August 2015.
4. Sam Davis, *Synchronous Buck Controller Can Step-Down from 48VIN to 1VOUT*, [powerelectronics.com](#), June 2015.
5. Sam Davis, *42V IC Features Both a 1.5A and a 2.5A Step-Down Regulator Channel*, [powerelectronics.com](#), May 2015.
6. Haifeng Fan, *Wide VIN and High-Power Challenges with Buck-Boost Converters*, [powerelectronics.com](#), June 2015.
7. Sam Davis, *Synchronous 4-Switch Buck-Boost DC/DC Controller*, [powerelectronics.com](#), May 2013.
8. Timothy Hegarty, *Post-Regulated Fly-Buck Powers Noise-Sensitive Loads*, [powerelectronics.com](#), October 2014.
9. Sam Davis, *Back to Basics: Voltage Regulators Part 2*, [powerelectronics.com](#), July 2013.
10. Carl Walding, *Forward-Converter Design Leverages Clever Magnetics*, [powerelectronics.com](#), August 2007.
11. Carl Walding, *Part One: Forward-Converter Design Leverages Clever Magnetics*, [powerelectronics.com](#), July 2007.
12. Kevin Daugherty, *Feedback Circuit Improves Hysteretic Control*, [powerelectronics.com](#), March 2008.
13. Ron Crews, *Negative Supply Uses Positive Hysteretic Regulator*, [powerelectronics.com](#), August 2007.
14. Sam Davis, *“Quiet” LDO Employs Unique Architecture to Cut Noise and Boost PSRR*, [powerelectronics.com](#), March 2015.
15. Sam Davis, *Multiphase Converter ICs Solve Powering Requirements for Microprocessors*, [powerelectronics.com](#), January 2009.

 [BACK TO TABLE OF CONTENTS](#)



CHAPTER 8: POWER-MANAGEMENT ICs

Power-management ICs provide management functions that support operation of the power distributed in the end-item electronic system. These ICs employ both analog and digital process for this supporting function.

Gate Driver ICs

Gate driver ICs are power amplifiers to drive power MOSFETs in power-supply applications. Inputs to these gate driver ICs are typically logic levels from PWM ICs. Outputs can be single-ended or dual synchronous rectifier drive. MOSFETs require 1.0A to 2.0A drive to achieve switching efficiently at frequencies of hundreds of kilohertz. This drive is required on a pulsed basis to quickly charge and discharge the MOSFET gate capacitances. Figure 8-1 shows a basic gate driver IC for a power MOSFET.

Gate drive requirements show that the Miller effect, produced by drain-source capacitance, is the predominant speed limitation when switching high voltages. A MOSFET responds instantaneously to changes in gate voltage and will begin to conduct when its gate threshold is reached and the gate-to-source voltage is 2.0V to 3.0V; it will be fully on at 7.0 V to 8.0 V.

Many manufacturers now provide logic level and low threshold voltage MOSFETs that require lower gate voltages to be fully turned on. Gate waveforms will show a porch at a point just above the threshold voltage that varies in duration depending on the amount of drive current available and this determines both the rise and fall times for the drain current.

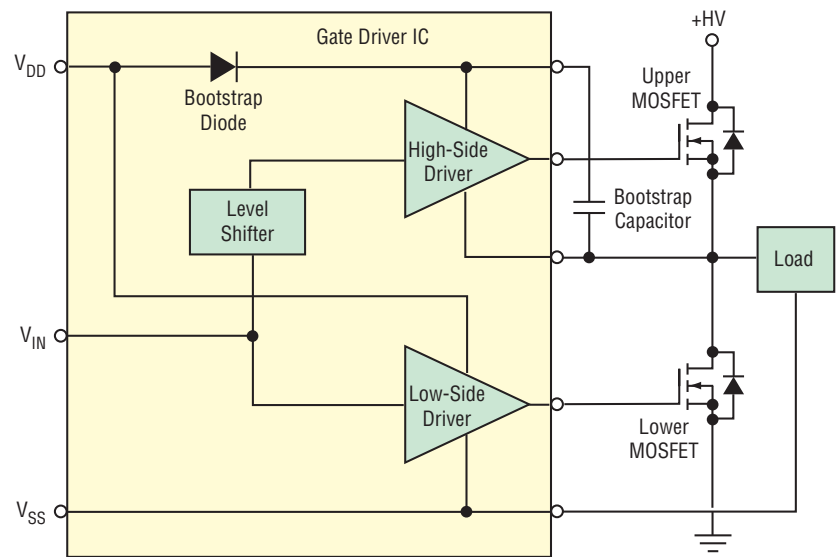

8-1. Basic high-side and low-side drivers in a gate driver IC provides for synchronous rectifier connected power MOSFETs.

ZXGD3009E6/DY

A pair of compact 40 V, 1 A-rated gate drivers from Diodes Inc. are specifically designed to control the high-current power MOSFETs used in on-board and embedded power supplies and motor drive circuits (Fig. 8-2). Enabling the MOSFETs to be more rapidly and fully switched on and off, the ZXGD3009E6 and ZXGD3009DY help minimize switching losses, improve power density, and increase overall conversion efficiency.

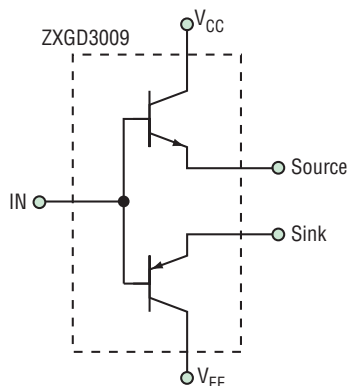

8-2. 40 V, 1 A-rated gate drivers from Diodes Inc. are intended to control the high-current power MOSFETs used in on-board and embedded power supplies and motor drive circuits.

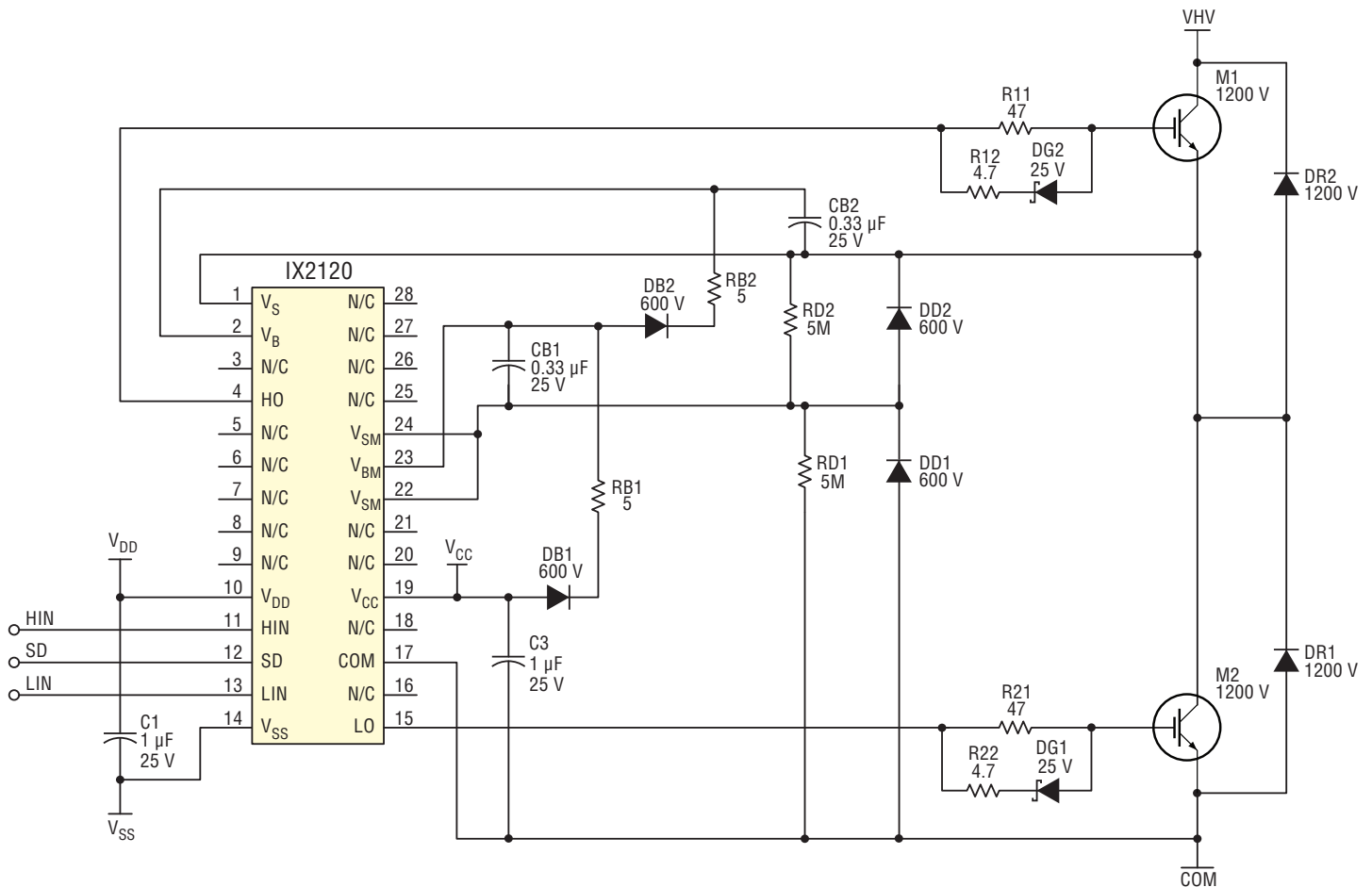

8-3. IXYS' IX2120 is a high-voltage IC that can drive high-speed MOSFETs and IGBTs that operate at up to +1200V.

Acting as a high-gain buffer stage for low-power control ICs, the devices can provide a typical drive current of 500 mA from an input current of only 10mA, ensuring the desirable fast charging and discharging of the power MOSFET's capacitive load. The drivers' switching capability is ultra-fast, with a propagation delay time of less than 5 ns, and rise and fall times of less than 20 ns.

Separate source and sink outputs offer independent control of MOSFET turn-on and turn-off times, which enables MOSFET behavior to be more closely tailored to the needs of the application. The ZXGD3009's ability to drive the gate negatively as well as positively assures dependable hard turn-off of the power MOSFET.

The gate drivers' rugged emitter-follower design avoids any issues of latch-up or shoot-through and can tolerate peak currents of up to 2 A. Their wide 40 V operating range will also cater to voltage spikes far beyond the typical 12 V normally associated with power MOSFET gate driving.

The ZXGD3009E6 is housed in a SOT26 package and the ZXGD3009DY is in an SOT363 package.

IX2120

IXYS IX2120 is a high-voltage IC that can drive high-speed MOSFETs and IGBTs and operates at up to +1200V (Fig. 8-3). The IX2120 is configured with independent high-side and low-side referenced output channels, both of which can source and sink 2A. The floating high-side channel can drive an N-channel power MOSFET or IGBT 1200V from the common reference.

High-voltage level-shift circuitry allows low-voltage logic signals to drive IGBTs in a high-side configuration operating up to 1200V. The IX2120B's 1400V absolute maximum rating provides additional margin for high-voltage applications.

The IX2120B is manufactured on IXYS ICD's advanced HVIC Silicon on Insulator (SOI) process, making the IX2120B extremely robust and virtually immune to negative transients and high dV/dt noise.

The inputs are 3.3V and 5V logic compatible. Internal undervoltage lockout circuitry for both the high-side and low-side outputs prevents the IX2120B from turning on the discrete power IGBTs until there is sufficient gate voltage. The output propagation delays are matched for

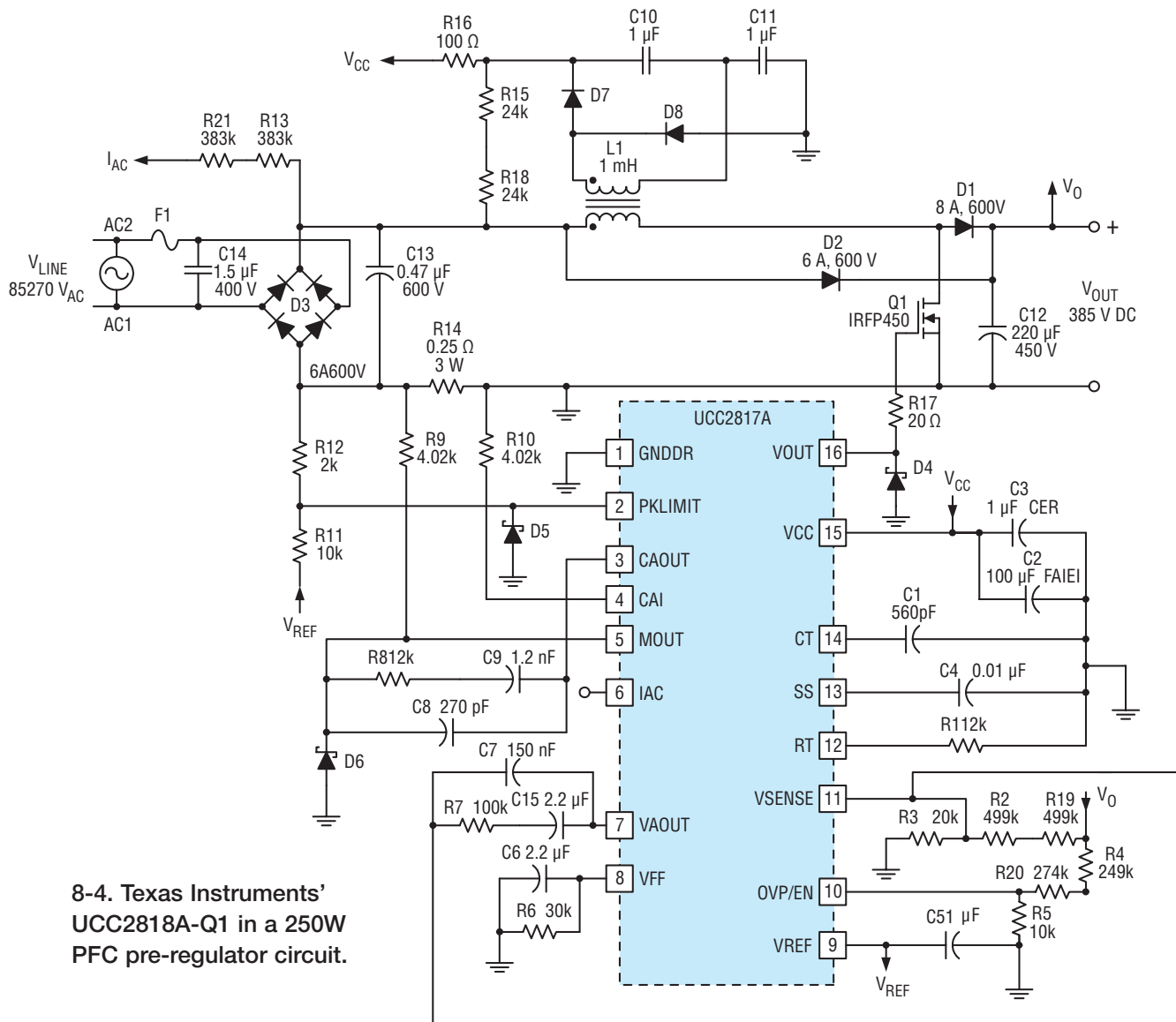

8-4. Texas Instruments' UCC2818A-Q1 in a 250W PFC pre-regulator circuit.

Typical application circuit

use in high-frequency applications.

The IX2120B can drive power discrete MOSFETs and IGBTs in half-bridge, full-bridge, and 3-phase configurations. Typical applications include motor drives, high-voltage inverters, uninterruptible power supplies (UPS), and dc/dc converters. The IX2120B complements IXYS ICD's extensive portfolio of high-voltage gate drivers, low-side gate drivers, and optically isolated gate drivers, and the full range of IXYS power semiconductors.

Features include:

- Floating channel for bootstrap operation to +600V with absolute maximum rating of +700V
- Outputs capable of sourcing and sinking 2A
- Gate drive supply range from 15V to 20V
- Enhanced robustness due to SOI process
- Tolerant to negative voltage transients: dV/dt immune

- 3.3V logic compatible
- Undervoltage lockout for both high-side and low-side outputs
- 28-pin SOIC package

Power-Factor Correction ICs

Most electronic systems use ac-dc switch-mode power converters that draw current from the powerline in a non-sinusoidal fashion that produces current and voltage distortions that can create problems with other equipment on the powerline.

Power factor describes the power relationships on an ac powerline. Current and voltage distortions occur with a reactive load, which has a real and a reactive power component. The vector sum of these two power components is the apparent power to the load. The phase angle

between the real power and reactive power is the power factor angle. With a resistive load, the reactive power is zero and the apparent power equals the real power and the power factor is unity, or 100%. If the load is reactive, the power factor is lower (less than 100%).

For a nonlinear load with a distorted current waveform, the current consists of fundamental line frequency and various harmonics. These harmonic currents do not contribute directly to the useful power dissipated in the load, but rather add to the reactive power to create a higher value of apparent power. Total harmonic distortion, THD, is a common way of specifying and measuring the amount of distortion present on a waveform. Note that THD can be higher than 100%.

Most commonly used techniques for power-system electronics incorporate a power-factor correction (PFC) circuit ahead of the other electronics on the assembly. An example would be the PFC correction circuitry on the front end of an off-line ac-dc power converter. In addition, most systems that employ an active PFC utilize feedback circuitry along with switch-mode converters to synthesize input current waveforms consistent with high power factor.

The boost topology is the most popular PFC implementation. Almost all present-day boost PFC converters utilize a standard controller chip for the purposes of ease of design, reduced circuit complexity, and cost savings. These ICs greatly simplify the process of achieving a reliable high-performance circuit. In order for the converter to achieve power-factor correction over the entire range of input line voltages, the converter in the PFC circuit must be designed so that the output voltage is greater than the peak of the input line voltage.

Figure 8-4 shows a typical application circuit for the UCC2818A-Q1 from Texas Instruments: a BiCMOS average current mode boost controller for high-power-factor high-efficiency pre-regulator power supplies. This active power-factor correction circuit pre-regulator programs the input current to follow the line voltage, forcing the converter to look like a resistive load to the line. A THD of less than 3% is possible with this circuit.

For the circuit of Fig. 8-4, a switching frequency of 100 kHz, a ripple current of 875 mA, a maximum duty cycle of 0.688, and a minimum input voltage of 85 VRMS produces a boost inductor value of about 1 mH. The values used are at the peak of low line, where the inductor current and its ripple are at a maximum.

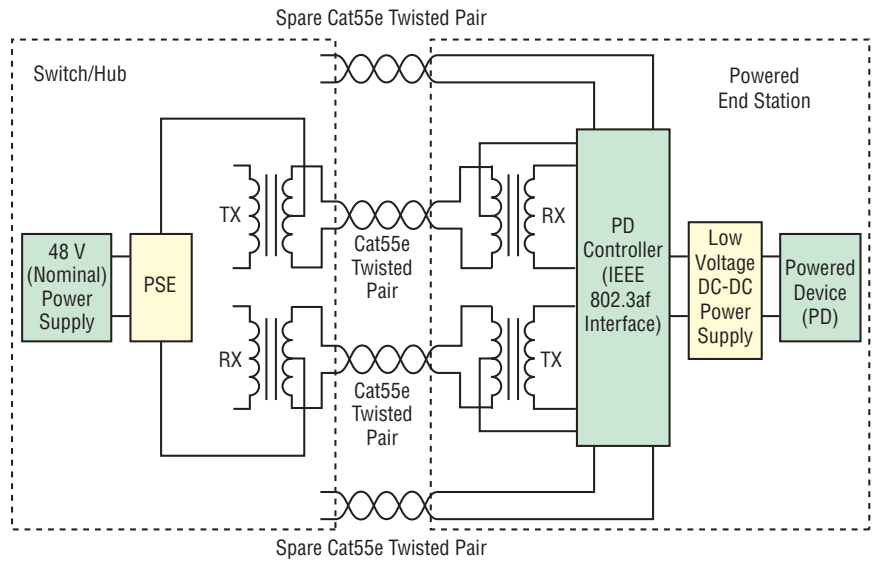

8-5. A Power-over-Ethernet system employs a power-source equipment (PSE) IC and a power-device (PD) IC and uses existing Ethernet cabling.

Power Over Ethernet (PoE) ICs

The IEEE 802.3af Standard states that all data terminal equipment (DTE) now has the option to receive power over existing cabling used for data transmission. The IEEE 802.3af Standard defines the requirements associated with providing and receiving power over the existing cabling. Figure 8-5 shows a typical Power-Over-Ethernet configuration. The power-sourcing equipment (PSE) provides the power on the cable and the powered device (PD) receives the power. As part of the IEEE 802.3af Standard, the interface between the PSE and PD is defined as it relates to the detection and classification protocol.

A PD draws power or requests power by participating in a PD detection algorithm. This algorithm requires the PSE to probe the link looking for a valid PD. The PSE probes the link by sending out a voltage between 2.8 V and 10 V across the power lines. A valid PD detects this voltage and places a resistance of between 23.75 k Ω and 26.25k Ω across the power lines. Naturally, the current varies depending on the input voltage. Upon detecting this current, the PSE concludes that a valid PD is connected at the end of the Ethernet cable and is requesting power.

If the PD is in a state in which it does not accept power, it is required to place a resistance above or below the values listed for a valid PD. On the lower end, a range between 12 k Ω and 23.75 k Ω signifies that the PD does not require power. On the higher end, the range is defined to be between 26.25 k Ω and 45 k Ω . Any resistance value less than 12 k Ω and greater than 45 k Ω is inter-

preted by the PSE as a non-valid PD detection signature.

After the detection phase, the PSE can optionally initiate a classification of the PD. The classification of a PD is used by the PSE to determine the maximum power required by the PD during normal operation. Five different levels of classification are defined by the IEEE 802.3af Standard.

Classification of the PD is optionally performed by the PSE only after a valid PD has been detected. To determine PD classification, the PSE increases the voltage across the power lines to between 15.5V and 20.5V. The amount of current drawn by the PD determines the classification.

Upon completion of the detection and optional classification phases, the PSE ramps its output voltage above 42V. Once the UVLO threshold has been reached, the internal FET is turned on. At this point, the PD begins to operate normally and it continues to operate normally as long as the input voltage remains above 30V. For most PDs, this input voltage is down-converted using an on-board dc-to-dc converter to generate the required voltages.

Designers can still supply power in a limited fashion in some existing Ethernet installations via a mid-span bridge. But in that case, designers can't implement power negotiations between a PD and PSE. This implies dedicated PoE Plus ports and relatively high duty-cycle power supplies in midspans.

Something else to watch out for is PDs that dynami-

cally negotiate power requirements with the PSE via their Ethernet connection. This requires more code in the PD microcontroller and a greater understanding of dynamic power requirements on the part of the engineer writing that code.

The original 802.3af PoE standard offered a fairly straightforward way to supply loads with up to 13 W of usable power delivered at 48 V dc. But IEEE 802.3at PoE Plus ups usable power to something over 50 W, and introduces some wrinkles that designers and even IT managers must understand.

MAX5980A

The **MAX5980A** from Maxim Integrated is a quad PSE power controller designed for use in IEEE 802.3at/af-compliant PSE (Fig. 8-6). This device provides PD discovery, classification, current limit, and load disconnect detections. The device supports both fully automatic operation and software programmability. The device also supports new 2-Event classification and Class 5 for detection and classification of high-power PDs. The device supports single-supply operation, provides up to 70W to each port (Class 5 enabled), and still provides high-capacitance detection for legacy PDs.

The device features an I2C-compatible, 3-wire serial interface, and is fully software configurable and program-mable. The device provides instantaneous readout of port current and voltage through the I2C interface. The device provides input undervoltage lockout (UVLO),

8-6. Maxim's **MAX5980A** provides PD discovery, classification, current limit, and load-disconnect detections.

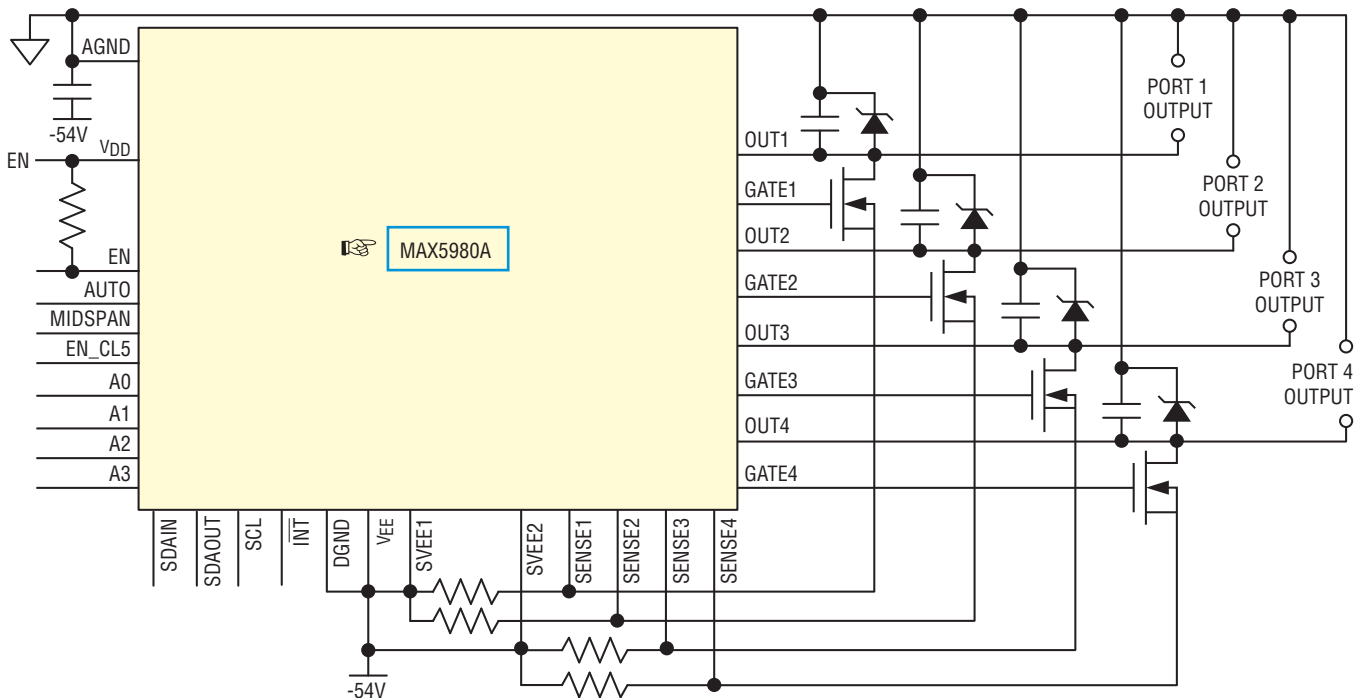

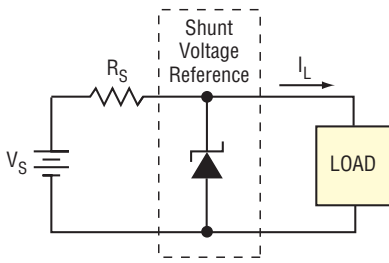

8-7. Shunt voltage reference.

input over-voltage lockout (OVLO), overtemperature protection, and output voltage slew-rate limit during startup.

The device provides four operating modes to suit different system requirements. By default, auto mode allows the device to operate automatically at its default settings without any software. Semiautomatic mode automatically detects and classifies devices connected to the ports, but does not power a port until instructed to by software. Manual mode allows total software control of the device and is useful for system diagnostics. Shutdown mode terminates all activities and securely turns off power to the ports.

Switching between auto, semiautomatic, and manual mode does not interfere with the operation of an output port. When a port is set into shutdown mode, all port operations are immediately stopped and the port remains idle until shutdown mode is exited.

Voltage Reference ICs

Voltage reference provides an accurate, temperature-compensated voltage source for use in a variety of applications. These devices usually come in families of parts that provide specific accurate voltages. Some families can have up to six different values with output

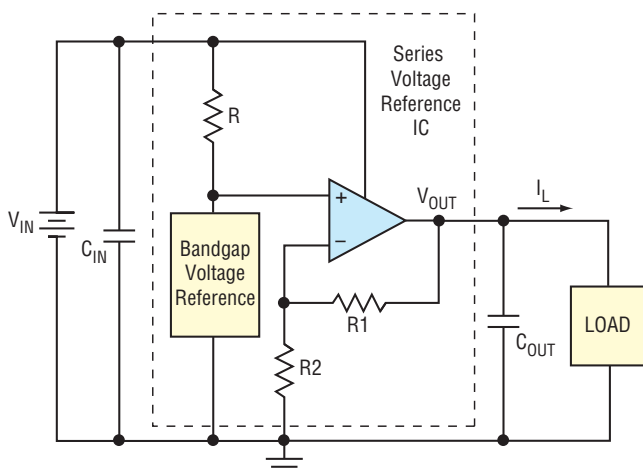

8-9. Texas Instruments' REF50xxA-Q1 IC family is a low-noise, precision-bandgap voltage reference that is specifically designed for excellent initial voltage accuracy and drift.

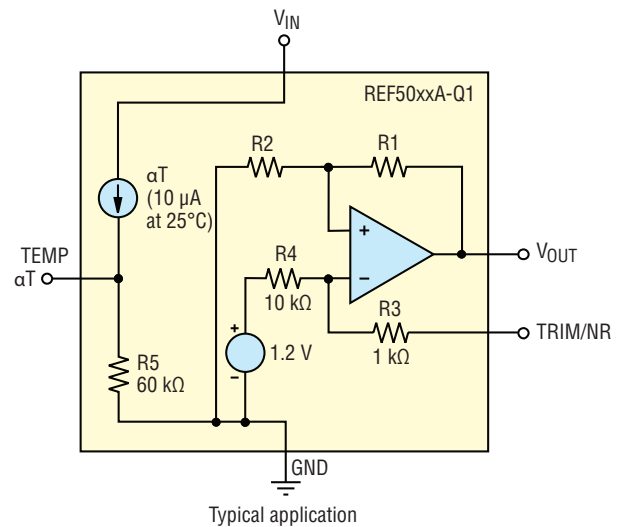

8-8. Series voltage reference.

voltages ranging from 1.225V to 5.000V. Initial output voltage accuracy and temperature coefficient are two of the more important characteristics.

Voltage references are available with fixed and adjustable reference voltage outputs. Adjustable output is set by a resistor divider connected to a reference pin. These references are either shunt (two-terminal) or series (three-terminal) types.

The ideal voltage reference has a perfect initial accuracy and maintains its voltage output independent of changes in temperature, load current, and time. However, the ideal characteristics are virtually impossible to attain, so the designer must consider the following factors:

Shunt references (Fig. 8-7) are similar to zener diodes in operation because both require an external resistor that determines the maximum current that can be supplied to the load. The external resistor also sets the minimum biasing current to maintain regulation. Consider shunt references when the load is nearly constant and power-supply variations are minimal.

Series references (Fig. 8-8) do not require any external components and they should be considered when the load is variable and lower-voltage overhead is important. They are also more immune to the power-supply changes than shunt references.

REF50xxA-Q1

Texas Instruments' REF50xxA-Q1 IC family is a low-noise, precision-bandgap voltage reference that is specifically designed for excellent initial voltage accuracy and drift. This family of voltage references features extremely low dropout voltage (Fig. 8-9). With the exception of the REF5020A-Q1 device, which has a minimum supply requirement of 2.7 V, these references can oper-

ate with a supply of 200 mV above the output voltage in an unloaded condition.

These reference ICs provide a very accurate voltage output. If desired, you can adjust VOUT to reduce noise and shift the output voltage from the nominal value by configuring the trim and noise-reduction pin (TRIM/NR, pin 5). The TRIM/NR pin provides a ± 15 mV adjustment of the device bandgap, which produces a ± 15 mV change on the VOUT pin.

This family of reference ICs allows access to the bandgap through the TRIM/NR pin. Placing a capacitor from the TRIM/NR pin to GND in combination with the internal 1 k Ω resistor creates a low-pass filter that lowers the overall noise measured on the VOUT pin. A capacitance of 1 μ F is suggested for a low-pass filter with a corner frequency of 14.5 Hz. Higher capacitance results in a lower cutoff frequency.

The REF50xxA-Q1 family has minimal drift error, which is defined as the change in output voltage over temperature. The drift is calculated using the box method. This reference family features a maximum drift coefficient of 8 ppm/ $^{\circ}$ C for the standard-grade.

Temperature output pin (TEMP, pin 3) provides a temperature-dependent voltage output with approximately

60-k Ω source impedance. This pin indicates general chip temperature, accurate to approximately $\pm 15^{\circ}$ C. Although this pin is not generally suitable for accurate temperature measurements, it can be used to indicate temperature changes or for temperature compensation of analog circuitry. A temperature change of 30 $^{\circ}$ C corresponds to an approximate 79 mV change in voltage at the TEMP pin.

VRM/VRD Power Management ICs

A voltage regulator module (VRM) is a buck converter that provides a microprocessor the appropriate supply voltage, converting +5 V or +12 V to a much lower voltage required by the CPU, allowing processors with different supply voltage to be mounted on the same motherboard.

Fig. 8-10 is a typical VRM circuit.

Some voltage regulator modules are soldered onto the motherboard, while others are installed in an open slot designed especially to accept modular voltage regulators. Some processors, such as Intel Haswell CPUs, feature voltage-regulation components on the same package (or die) as the CPU, instead of having a VRM as part of the motherboard; such a design brings certain levels of simplification to complex voltage regulation involving numerous CPU supply voltages and dynamic powering up and down of various areas of a CPU. A voltage regulator integrated on-package or on-die is usually referred to as fully integrated voltage regulator (FIVR) or integrated voltage regulator (IVR).

Most modern CPUs require less than 1.5 V, as CPU designers tend to use smaller CPU core voltages; lower voltages help in reducing CPU power dissipation, which is often specified through thermal design power (TDP) that serves as the nominal value for designing CPU cool-

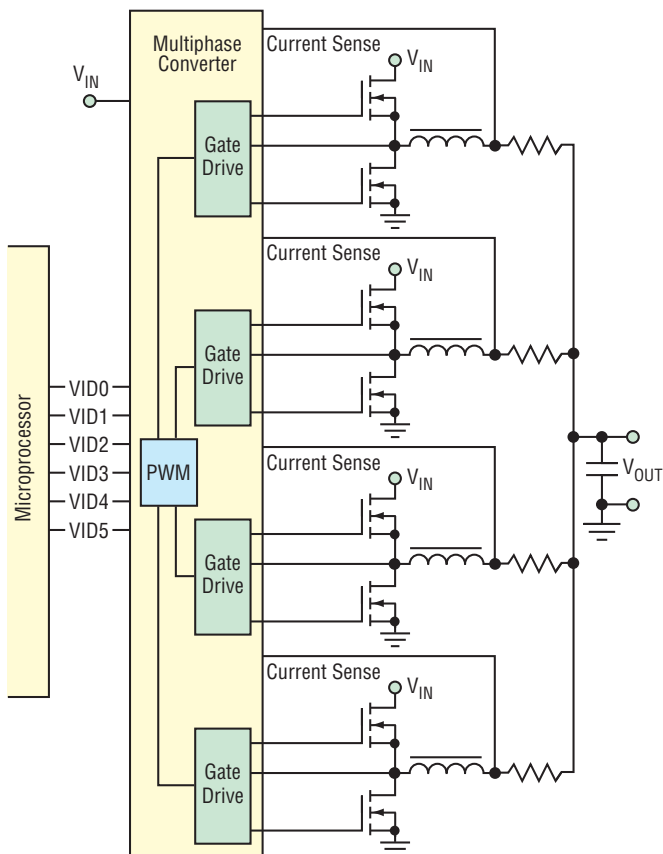

8-10. VRM responds to the VID code from the microprocessor to provide the proper dc voltage.

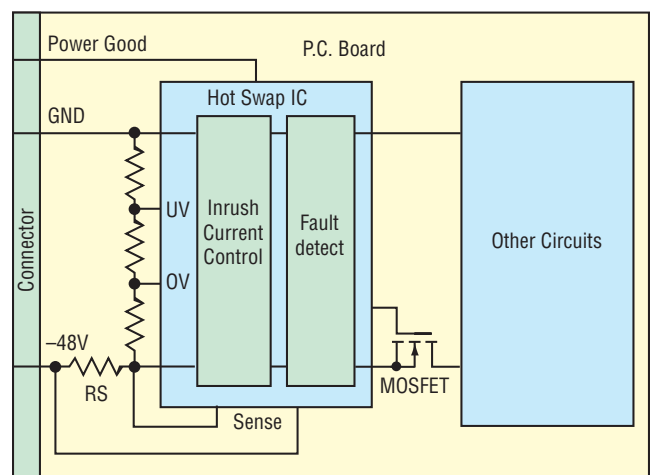

8-11. Hot-swap control IC provides startup current-limiting, undervoltage, overvoltage, and current monitoring that prevents power-supply failure.

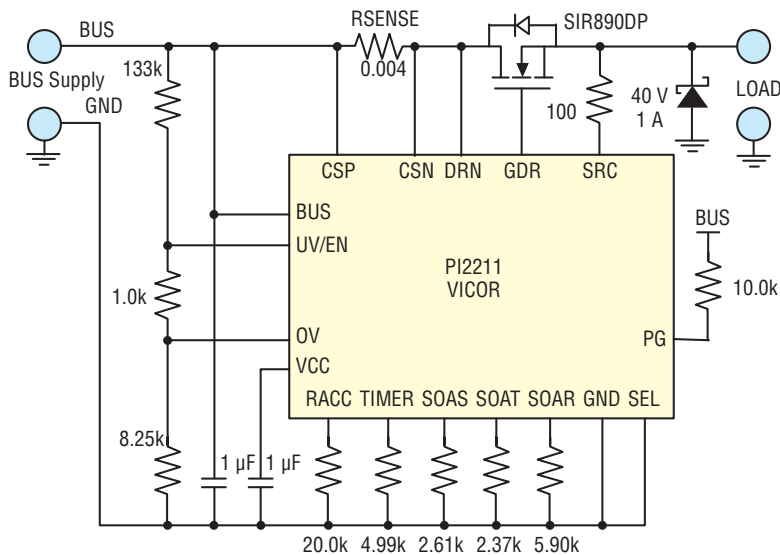

8-12. Picor's PI2211 hot-swap controller and circuit breaker ensures safe system operation during circuit card insertion by limiting the start-up or in-rush.

ing systems.

Some voltage regulators provide a fixed supply voltage to the processor, but most of them sense the required supply voltage from the processor, essentially acting as a continuously variable adjustable regulator. In particular, VRMs that are soldered to the motherboard are supposed to do the sensing, according to the Intel specification.

Modern graphics processing units (GPUs) also use a VRM due to higher power and current requirements. These VRMs may generate a significant amount of heat and require heat sinks separate from the GPU.

The VRM concept was developed by Intel to guide the design of dc-dc converters that supply the required voltage and current to a Pentium microprocessor. The maximum voltage is determined by the five- to seven-bit VID (Voltage Identity) code provided to the VRM. The VID code connects the power supply controller to the corresponding pins on the microprocessor (Fig. 8-10). Therefore, the internal coding in the microprocessor controls the dc voltage applied to processor. VRM guidelines are intended for a special module, usually a small circuit board, that plugs into the computer system board and supplies power for the microprocessor.

A later version of guidelines are for a similar circuit called the Voltage Regulator-Down (VRD) developed by Intel to guide the design of a voltage regulator integrated onto the computer system motherboard with a single processor. These guidelines are based on the six-bit VID code.

At the present time and in the near future the VRM

and VRD circuits must provide 60A to 100A for the Intel microprocessors. At this time, the only practical circuit that can provide those current levels is the multiphase configuration. Multiphase converters employ two or more identical, interleaved converters connected so that their output is a summation of the outputs of the cells.

Hot-Swap Controller ICs

Often, equipment users want to replace a defective board without interfering with system operation. They can do this by removing the existing board and inserting a new board without turning off system power, a process called "hot-swap." Figure 8-11 shows a typical hot-swap IC circuit. When inserting a plug-in module or p.c. card into a live chassis slot, the discharged supply bulk capacitance on the board can draw huge transient currents from the system supplies. Therefore, the hot-swap circuit must provide some form of inrush limiting, because these currents can reach peak magnitudes ranging up to several hundred

amps, particularly in high-voltage systems. Such large transients can damage connector pins, p.c. board etch, and plug-in and supply components. In addition, current spikes can cause voltage droops on the power distribution bus, causing other boards in the system to reset. Therefore, a hot-swap control IC must provide startup current limiting, undervoltage, overvoltage, and current monitoring that prevents power supply failure.

At a hardware level, the hot-swap operation requires a reliable bus isolation method and power management. With today's power-hungry processors, careful power ramp up and ramp down is a must, both to prevent arcing on power pins and to minimize backplane voltage glitches.

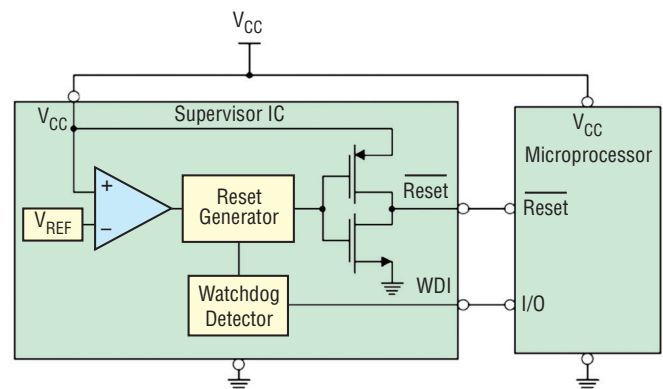

8-13. Supervisory IC ensures that the system power supplies operate within specified voltage and time windows.

Connectors employed in these systems must also allow safe and reliable hot-swap operation. One technique is to use staged pins on the backplane with different lengths. This allows events to occur in a time-sequenced manner as cards are inserted and removed. It enables the power ground and signal pins to be disconnected and then connected in an appropriate sequence that prevents glitches or arcing. After insertion, an enable signal informs the system to power up so that bus-connect and software initialization can begin.

One software sequence of the extraction-insertion process starts with an interrupt signal informing the operating system of the impending event. After the operating system shuts down the board's functions, it signals the maintenance person or operator via an LED that it is okay to remove the board. After installing a new board, the operating system automatically configures the system software. This signaling method allows the operator to install or remove boards without the extra step of reconfiguring the system at the console.

PI2211

The PI2211 hot-swap controller and circuit breaker from Picor ensures safe system operation during circuit card insertion by limiting the start-up or in-rush current to the load and eliminating the electrical disturbance or possible voltage sag imposed on a backplane power supply. During steady state operation, the PI2211 acts as a circuit breaker, disconnecting from the backplane power source if an overcurrent condition arises. The PI2211 uses an external N-channel MOSFET and employs the MOSFET's transient thermal characteristics (supplied by the MOSFET supplier) to ensure operation within the MOSFET's dynamic safe operating area (SOA).

In Fig. 8-12, the PI2211 limits the start-up current to a load, eliminating the electrical disturbance or possible voltage sag imposed on a backplane power supply. The PI2211 performs hot-swap protection during power-up or insertion and acts as a circuit breaker during steady state operation. The PI2211 performs these protection functions by controlling an external MOSFET and limiting the MOSFET junction temperature rise to a safe level, a key requirement for hot swap power managers expected to operate over wide dynamic conditions.

Upon insertion, the PI2211 initiates a user-programmable turn-on delay where the gate of the MOSFET is held "off," providing input BUS de-bounce. The PI2211 then turns "on" the MOSFET pass element in a controlled manner, limiting the current to a pre-defined level based on the value of a user-selected sense resistor. The PI2211 circuit breaker threshold protects against over-current by comparing the voltage drop across this

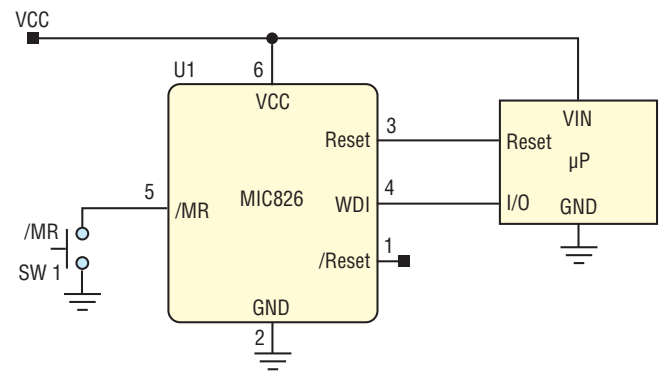

8-14. Micrel's MIC826 is a low-current, ultra-small voltage supervisor with manual reset input, watchdog timer, and active-high and active-low push-pull outputs.

sense resistor with a fixed internal reference voltage. Once the load voltage has reached its steady-state value, the Power-good pin is asserted "high" and the start-up current limit is disabled. Under Voltage (UV) and Over Voltage (OV) trip points (user settable) ensure operation within a defined operating range in addition to a Enable/Disable feature shared with the UV input.

With Power-good established, the load current is continuously monitored by the PI2211 with the MOSFET operating in the low-loss RDS(ON) region. In this steady state operation, the PI2211 now acts primarily as a circuit breaker. An over-current threshold is fixed to be twice the start-up current limit and sets an upper current boundary that determines when a gross fault has occurred. Exceeding this boundary will initiate the PI2211 Glitch-Catcher circuitry and assert the power good pin low. Glitch-Catcher prevents overvoltage events caused by the energy stored in the parasitic inductance of the input power path in response to a rapid interruption of the forward current during an overcurrent fault event. Acting as an active snubber, this circuitry mitigates the need for large external protection components by shunting the energy through the MOSFET to the low impedance load.

For the design example of Fig. 8-12, system requirements are:

- Nominal BUS voltage (VBUS) = 12V
- High BUS voltage where controller must be enabled (VBUSHIGH) = 12.5V
- Low BUS voltage where controller must be enabled (VBUSLOW) = 11.5V
- Maximum Operating Current (IMAX) = 10A
- Circuit Breaker Threshold (ICB) = 13A
- Hot-Swap Efficiency > 99%
- Schottky Diode is 40V, 1A; required to protect the SCR pin from negative voltage transients that can damage

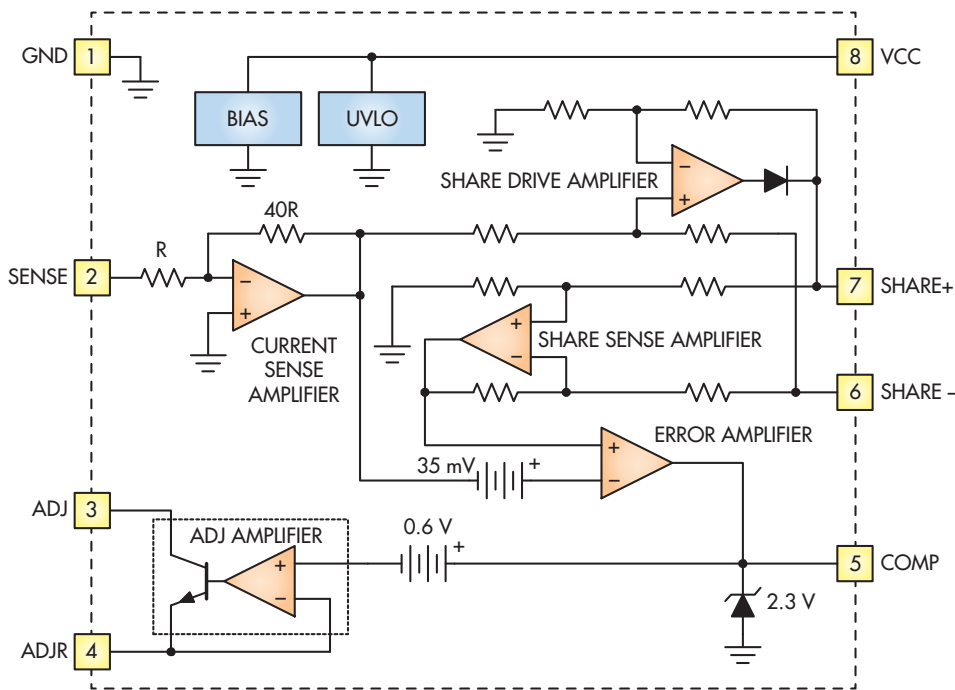

8-15. Texas Instruments' UC3902 is a load-share controller IC that distributes load currents equally among paralleled voltage-stabilized supplies.

the controller. The 100Ω series resistor is used to limit current.

Supervisor ICs

Supervisory ICs ensure that the system-power supplies operate within specified voltage and time windows. In its most basic form, a supervisory IC compares a power supply voltage with a specific threshold. If the power source reaches that threshold, the supervisory IC generates a pulse that resets the system processor.

Figure 8-13 shows a simplified diagram of supervisor IC and its associated microprocessor. The voltage monitoring section of the supervisory IC includes a comparator and voltage reference as well as reset generator that can reset the associated microprocessor. Usually, supervisor ICs consist of a family of parts set for different thresholds, such as 1.5 V, 1.8 V, etc. There are also supervisor ICs that have adjustable thresholds. This supervisor IC has a watchdog timer that protects against an interruption in software execution. Usually, the watchdog timer is a restartable timer whose output changes state on timeout, resetting the system processor or generating an interrupt.

Many systems require multiple supply voltages that can be monitored with multiple devices, but some of the supervisory ICs can monitor two or more voltages. Typically, the number of threshold voltages required in a system depends on the number of processor and periph-

eral power supplies.

The reset function of the supervisory IC may provide a power-on-reset (POR) to eliminate problems during power-up or a supply voltage sag. These problems can occur because of a slow-rising supply voltage, a supply voltage that exhibits noise or poor behavior during startup, or recovery from a sag. Typically, the reset circuit's voltage tolerance should not exceed ±2.7% over temperature.

Many supervisory ICs include undervoltage and overvoltage comparators with programmable thresholds. Inputs for these comparators can implement a windowed reset that warns if a particular voltage is either too high or too low.

To ensure the continuity of processor memory contents and other critical functions if a supply voltage is lost, many of the older supervisory circuits are able to switch the memory's power source to a backup battery.

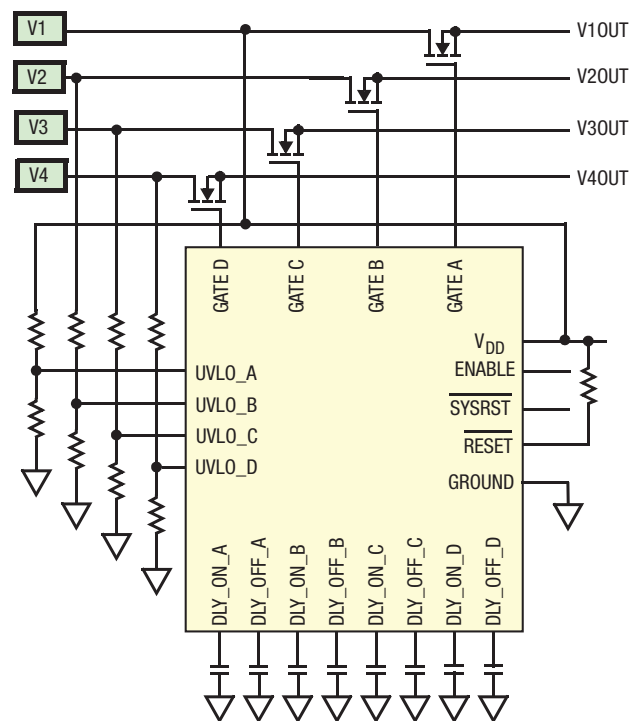

8-16. Intersil ISL6123 is an integrated 4-channel controlled-on/controlled-off power-supply sequencer.

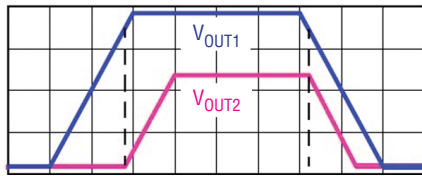

8-17.1. Output sequencing.

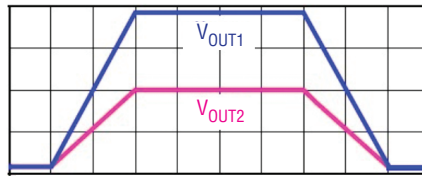

8-17.2. Ratiometric tracking.

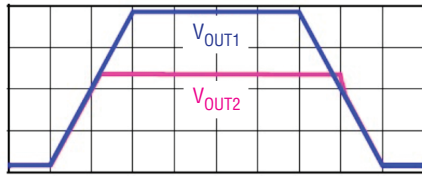

8-17.3. Coincidental tracking.

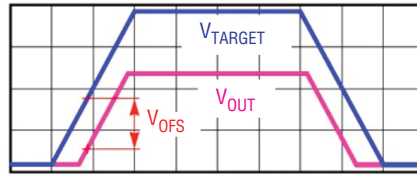

8-17.4. Offset voltage tracking.

MIC826

Micrel's MIC826 is a low-current, ultra-small, voltage supervisor with manual reset input, watchdog timer, and active-high and active-low push-pull outputs (Fig. 8-14). This provides the designer with high integration while reducing solution size up to 70% compared to competing solutions. The IC also improves the accuracy of the power supply monitor by 1 to 2% over the -40°C to $+125^{\circ}\text{C}$ temperature range. This makes it an ideal solution for portable, as well as industrial and automotive applications.

It contains eight reset threshold options and is intended to monitor 1.8V to 5V power supplies. The IC features a ± 0.5 percent voltage threshold accuracy at room temperature and ± 1.5 percent voltage threshold accuracy over the -40°C to $+125^{\circ}\text{C}$ temperature range. The solution consumes a low $3.8\mu\text{A}$ of supply current for power supplies; lower than 3.6V and $4.8\mu\text{A}$ for solutions operating from a 5V power supply. The IC also features an industry standard reset timeout period of 140ms (min) and a watchdog time output period of 1.6s. The watchdog input can be left unconnected for applications that do not require watchdog monitoring.

The MIC826 consumes a quiescent current of only $3.8\mu\text{A}$ and is offered in a tiny, space-saving, 6-pin 1.6mm x 1.6mm Thin DFN package.

Load-Share Controller ICs

System integrators can improve system reliability with redundant, paralleled power supplies that share the load. Load-sharing distributes load currents equally among paralleled voltage-stabilized supplies. For the shared supplies to operate efficiently, the power system must ensure that no supply hogs the load current while other supplies are essentially idle. Also, the power system must be able to tolerate the failure of any one supply

as long as there is sufficient current capacity from the remaining supplies. This requires the combination of power supplies to behave like one large power supply with equal stress on each of the units.

Individual load-shared supplies require an external controller, otherwise the supply with the highest output voltage will contribute most of the output current. Output impedance of typical power supplies is in the milliohm range so a small difference in output voltages can cause a relatively large difference in output currents. This might cause the

supply providing the majority of load current to enter the current-limit mode, increasing its thermal stress, which would decrease system reliability. A load-shared system should have a common, low bandwidth share bus interconnecting all supplies. It should also have good load-sharing transient response and the ability to margin the system output voltage with a single control.

The UC3902 from Texas Instruments is a load share controller IC that balances the current drawn from independent, paralleled power supplies (Fig. 8-15). Load sharing is accomplished by adjusting each supply's output current to a level proportional to the voltage on a share bus.

The master power supply, which is automatically designated as the supply that regulates to the highest

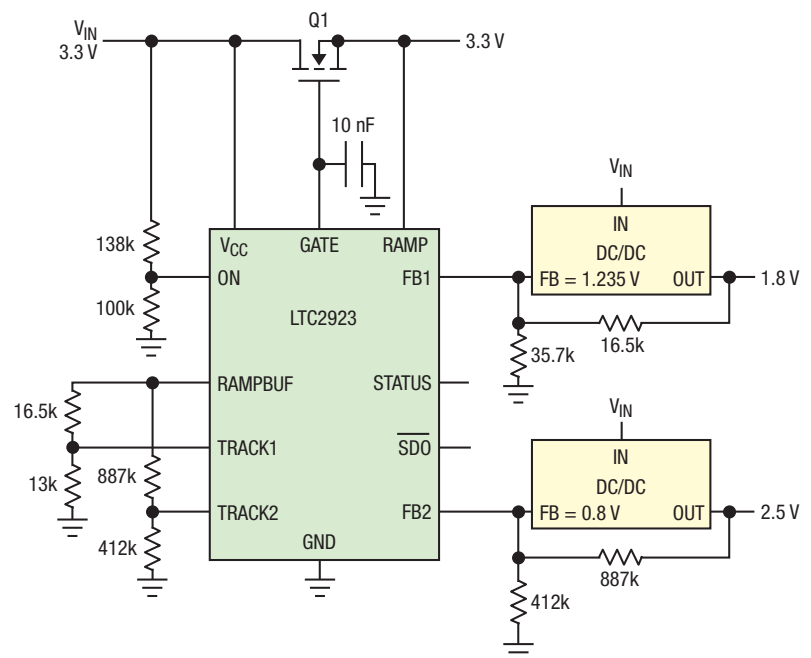

8-18. Linear Technology's LTC2923 sink/source tracking termination regulator.

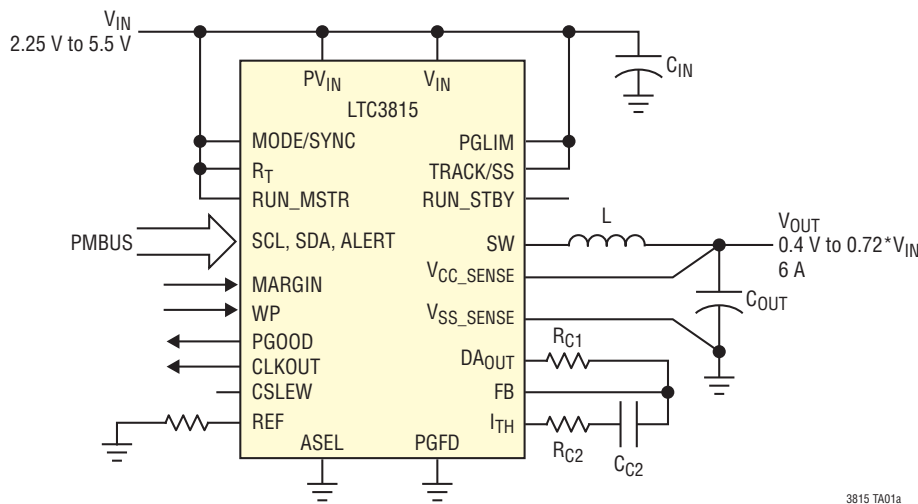

8-19. Linear Technology's LTC3815 provides up to $\pm 25\%$ margining adjustment at 0.1%/bit resolution around the reference voltage.

voltage, drives the share bus with a voltage proportional to its output current. The UC3902 trims the output voltage of the other paralleled supplies so that they each support their share of the load current. Typically, each supply is designed for the same current level although that is not necessary for use with the UC3902. By appropriately scaling the current sense resistor, supplies with different output current capability can be paralleled with each supply providing the same percentage of their output current capability for a particular load.

Power Supply Management ICs

There are a variety of power-up profiles to satisfy the requirements of digital logic circuits including FPGAs, PLDs, DSPs and microprocessors. Certain applications require one supply to come up after another. Other applications require the potential difference between two power supplies must never exceed a specified voltage. This requirement applies during power-up and power-down as well as during steady-state operation.

The Intersil ISL6123 is an integrated 4-channel controlled-on/controlled-off power-supply sequencer (Fig. 8-16) with supply monitoring, fault protection and a "sequence completed" signal (RESET).

Figure 8-17.1. Timing diagram for output sequencing
 Figure 8-17.2. Timing diagram for ratiometric tracking
 Figure 8-17.3. Timing diagram for coincidental tracking
 Figure 8-17.4. Timing diagram for offset voltage tracking

Another power-supply management function is tracking that ramps supplies outputs up and down together. In other applications it is desirable to have the supplies ramp up and down with fixed voltage offsets between them or to have them ramp up and down ratiometrical-

ly. Linear Technologies' LTC2923 can provide power-supply tracking and sequencing. The associated supplies can be configured to ramp-up and ramp-down together or with voltage offsets, time delays or different ramp rates (Fig. 8-18).

Voltage margining is a means of verifying the robustness of a product by intentionally adjusting its supply voltages to their limits and then evaluating the product's performance. This process evaluates the load circuit's ability to tolerate changes in the power supply voltages that may occur over time and temperature. The testing is typically performed by forcing the power supply to $\pm 5\%$ of its nominal output voltage

and then ensuring that the equipment still passes its final acceptance test.

The LTC3815 from Linear Technology is a high-efficiency, 6A monolithic synchronous buck regulator using a phase lockable controlled on-time, current mode architecture (Fig. 8-19). Its I²C-based PMBus interface allows the output voltage to be margined using its internal 9-bit DAC that provides up to $\pm 25\%$ adjustment at 0.1%/bit resolution around the reference voltage set at the REF pin.

The digital offset value is changed with a PMBus command. When a change in the reference is detected, the reference is ramped (0.1%/step) from its current value to the new value at a rate set by the capacitor value connected to the CSLEW pin, which provides a programmable slew rate of the V_{OUT} transition. If desired, you can pre-load the LTC3815 with two additional offsets using PMBus commands. The reference offset can then be switched between any of these three register values with the 3-state MARGIN pin. When using the MARGIN pin, the latency of the V_{OUT} transition is limited only by the chosen CSLEW capacitor and the loop bandwidth of the power supply. Changes to these registers are prevented by pulling the write protect (WP) pin high.

Intelligent Power-Switch ICs

Automotive body electronics modules routinely use intelligent power switches to control loads such as lamps, LEDs, solenoids, and motors. These switches replace mechanical relays to reduce mechanical noise, and shrink module size while increasing functionality.

Many years of development have produced today's low-cost devices that are efficient, safe, flexible, reliable, robust, and fault-tolerant. Now, those same advances are

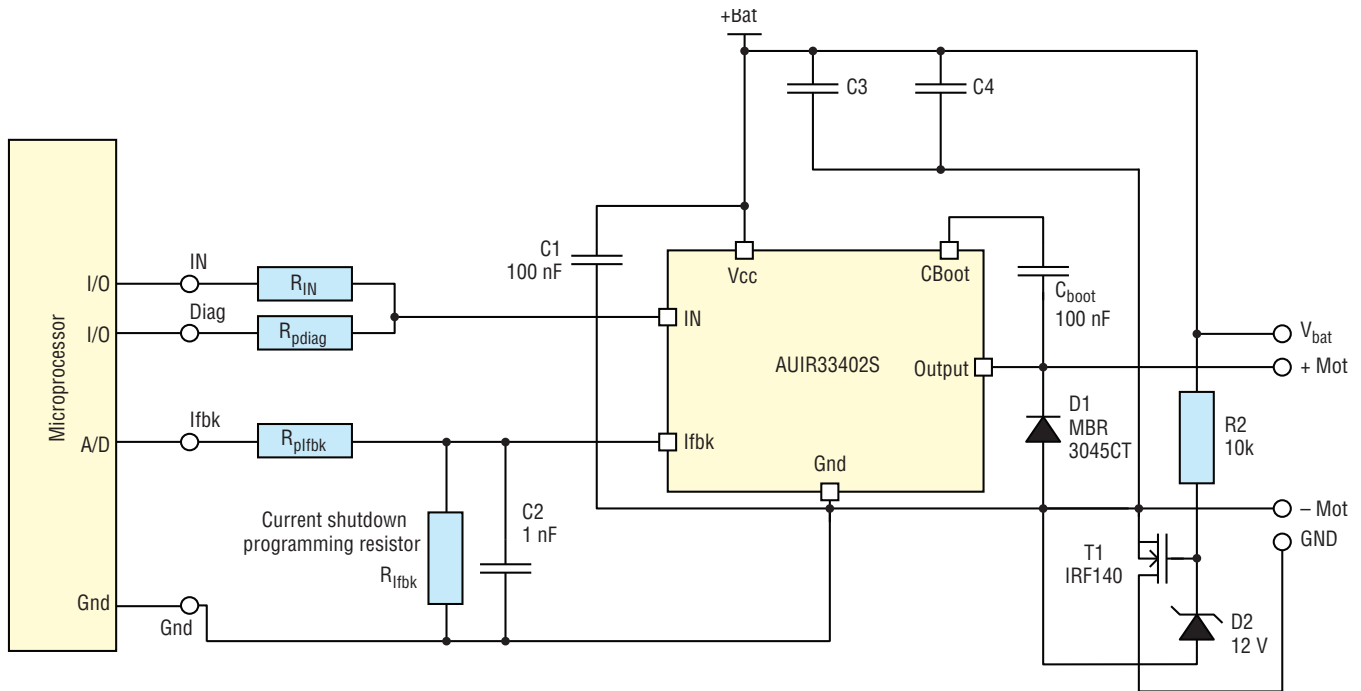

8-20. Recommended circuit for International Rectifier’s AUIR33402S used as an intelligent power module to drive a motor.

being extended to intelligent power switches designed for the more demanding requirements of 24 V systems. Requirements of a solid-state switch for 24 V truck and bus systems must consider what we have already learned from the use of solid state switches in 12 V systems. Many of the requirements of 12 and 24 V systems are similar.

The primary requirement is low cost. Here, the entire system cost as well as the device cost is of interest. This

includes the cost of thermal management, MCU overhead and pin count, PCB area for mounting and routing, additional circuitry needed for diagnostics and fault management, protection components such as capacitors needed to suppress voltage transients, etc. To minimize system costs associated with managing power, the latest devices have very low on-resistances to reduce power dissipation. Additionally, their SPI interface makes many control and diagnostic features possible and reduces MCU overhead and pin count. The SPI interface also greatly reduces routing complexity and saves PCB area.

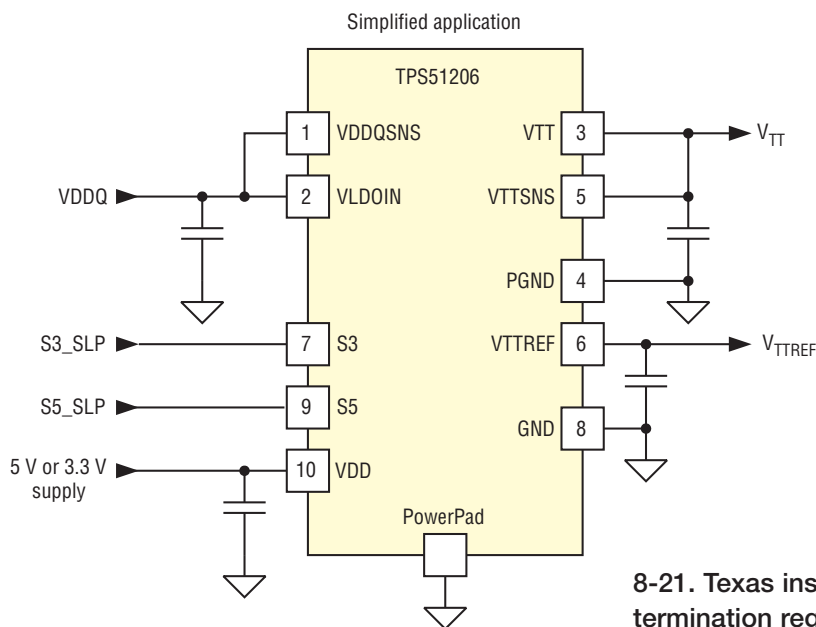

8-21. Texas instruments’ TPS51206 DDR is a sink/source tracking termination regulator.

International Rectifier’s AUIR33402S is a seven-terminal, high-side switch for a variable speed dc motor whose features simplify the design of the dc motor drive with a microcontroller. The MOSFET switches the power load proportionally to the input signal duty cycle at the same frequency and provides a current feedback on the I_{FBK} pin. The over-current shutdown is programmable from 10A to 33A. Over-current and over-temperature latch OFF the power switch, providing a digital diagnostic status on the input pin. In sleep mode, the device consumes less than 10uA. Further integrated protections such as ESD, GND and Cboot disconnect protection

5 V or 3.3 V supply

guarantee safe operation in harsh conditions of the automotive environment.

The recommended connection with reverse battery protection is shown in Fig. 8-20. The basic circuit provides all the functionality to drive a motor up to 33A DC. Rlfbk sets both the level current shutdown and the current feedback reading scale.

DDR Memory Termination Supply ICs

DDR memories require terminal regulators, power supplies that minimize timing skew and power dissipation. The voltages involved in this termination process are VDDQ, VTT, and VREF. According to the JEDEC specification: $VTT = 0.5(VDDQ)$, VREF is a buffered reference voltage that also tracks $0.5(VDDQ)$ and VTT must track VREF with $<40\text{mV}$ offset regardless of variations in voltage, temperature, and noise.

DDR memory systems employ Series Stub Termination Logic (SSTL) that improves signal integrity of the data transmission across the memory bus. This termina-

tion scheme is essential to prevent data error from signal reflections while transmitting at high frequencies encountered with DDR RAM. This termination configuration prevents data error from signal reflections while transmitting at the high frequencies associated with DDR memory. It involves the use of the termination regulator and termination resistors that regulate the voltage to $0.5(VDDQ)$.

The TPS51206 from Texas Instruments (Fig. 8-21) is a sink/source tracking termination regulator specifically designed for low input voltage, low cost, and low external component count systems where space is a key application parameter. The TPS51206 integrates a high-performance, low-dropout (LDO) linear regulator (VTT) that has ultimate fast response to track $\frac{1}{2} VDDQSNS$ within 40 mV at all conditions, and its current capability is 2 A for both sink and source directions.

A 10- μF (or greater) ceramic capacitor(s) need to be attached close to the VTT terminal for stable operation; X5R or better grade is recommended. To achieve tight regulation with minimum effect of trace resistance, the

8-22. Maxim's **MAX16928** powers TFT LCDs with integrated boost converter, 1.8V/3.3V regulator controller, positive-gate voltage regulator, and negative-gate voltage regulator.

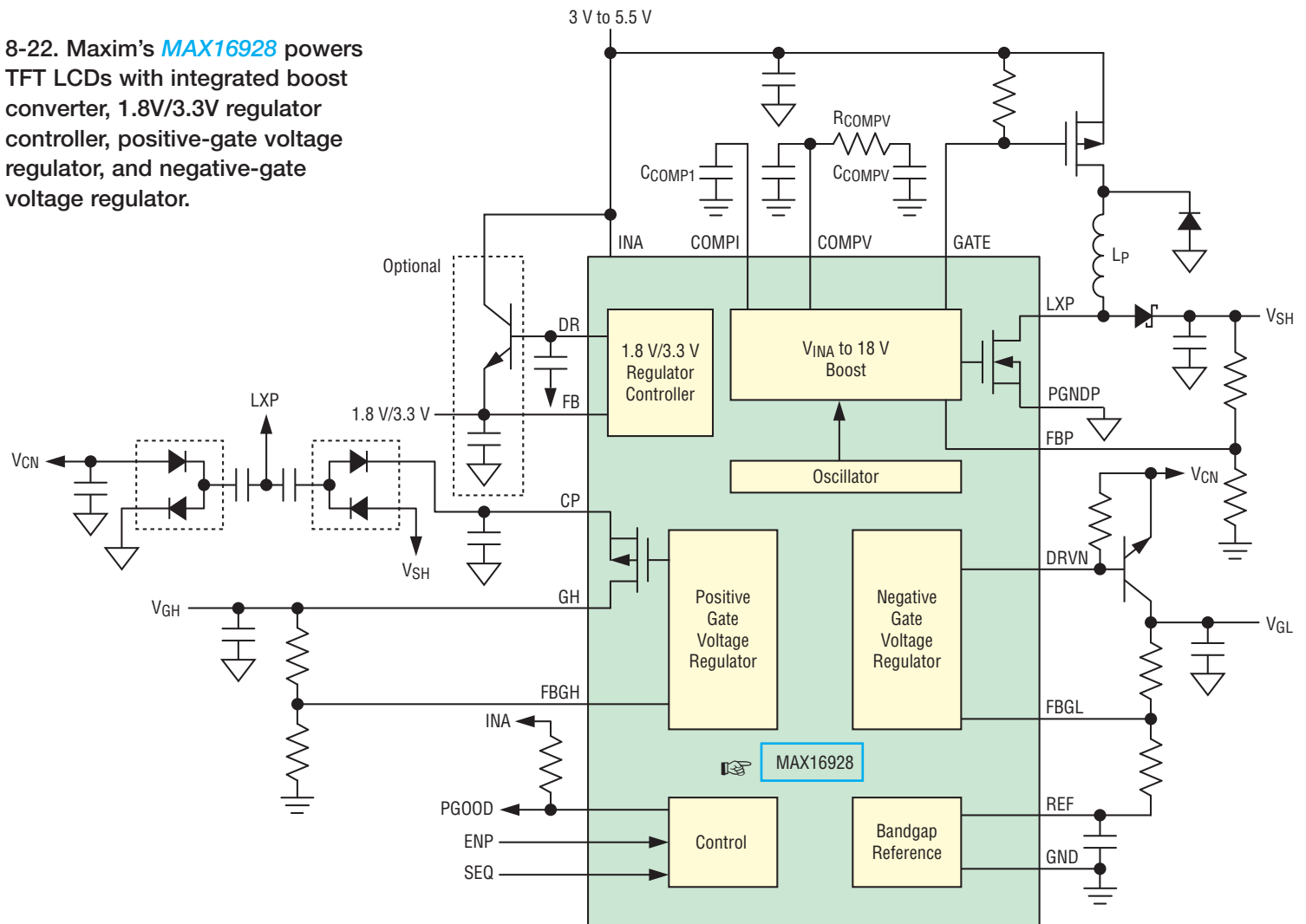

remote sensing terminal, VTTSENS, should be connected to the positive terminal of the output capacitor(s) as a separate trace from the high current path from the VTT pin.

The TPS51206 has a dedicated pin, VLDOIN, for VTT power supply to minimize the LDO power dissipation on user application. The minimum VLDOIN voltage is 0.4 V above the $\frac{1}{2}$ VDDQSNS voltage.

LCD Power-Management ICs

Charge pump, switch mode, and LDO techniques are used by various ICs to power color thin film transistor (TFT) liquid crystal displays (LCDs). These ICs usually employ a combination of dc-dc converter technologies to provide the multiple voltages required by an LCD.

An example of a highly integrated power supply for automotive TFT-LCD applications is the **Maxim MAX16928** (Fig. 8-22). The IC integrates a boost converter, 1.8V/3.3V regulator controller, positive-gate voltage regulator, and negative-gate voltage regulator.

It achieves enhanced EMI performance through spread-spectrum modulation. Digital input control allows the device to be placed in a low-current shutdown mode

and provides flexible sequencing of the gate voltage regulators.

Internal thermal shutdown circuitry protects the IC. It will shut down if its die temperature reaches $+165^{\circ}\text{C}$ (typ) and will resume normal operation once its die temperature falls 15°C .

It is factory-trimmed to provide a variety of power options to meet the most common automotive TFT-LCD display power requirements.

Its boost converter employs a current-mode, fixed-frequency PWM architecture to maximize loop bandwidth and provide fast transient response to pulsed loads typical of TFT-LCD panel source drivers. The 2.2MHz switching frequency allows use of low-profile inductors and ceramic capacitors that minimize thickness of LCD panels. An integrated low on-resistance MOSFET and the IC's built-in digital soft-start functions reduce the required number of external components while controlling inrush currents. Using an external resistive voltage divider you can set output voltage from VINA to 18V. The regulator controls the output voltage by modulating the duty cycle (D) of the internal power MOSFET in each switching cycle.

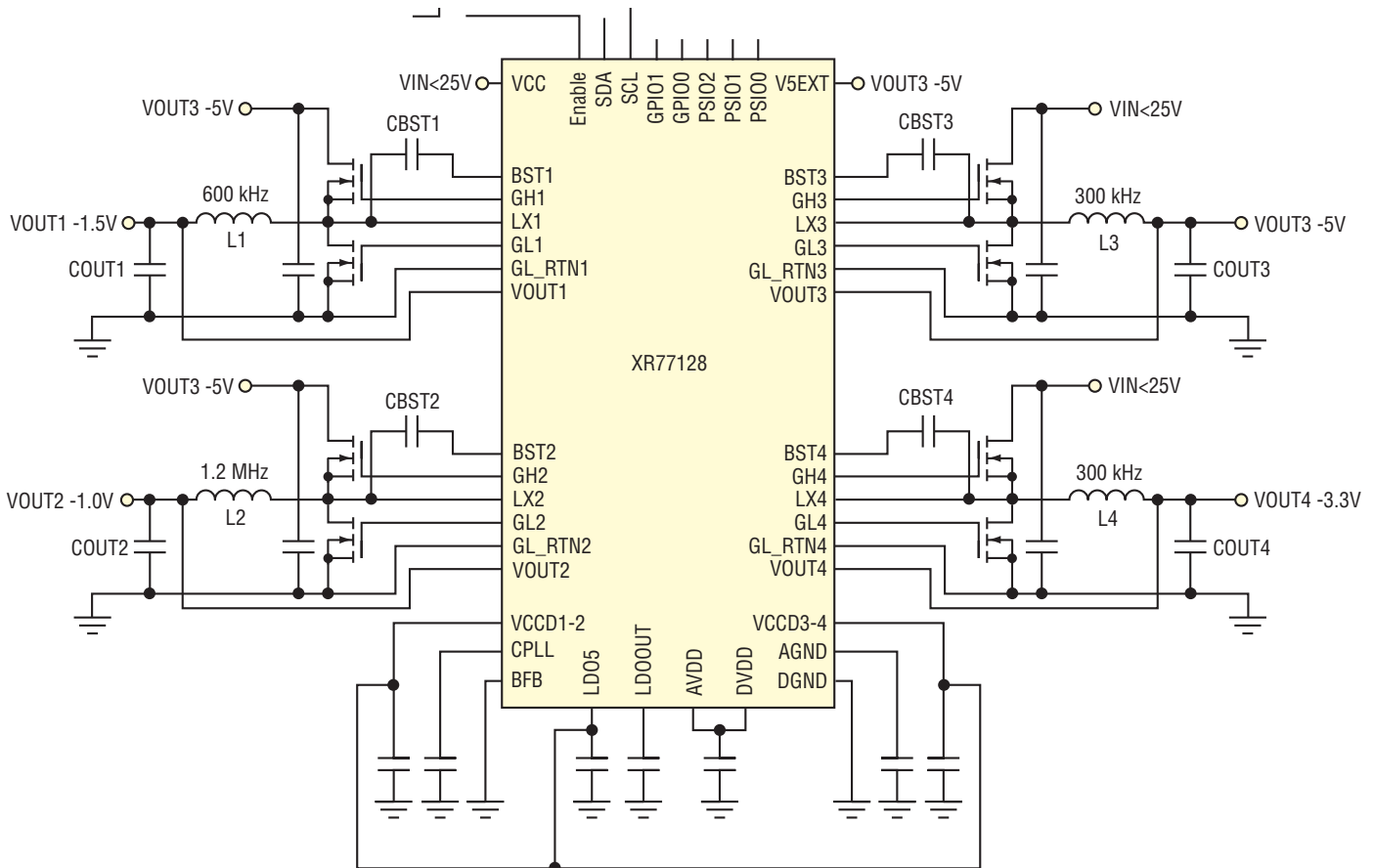

8-23. Exar's XR77128 is a four-channel digital PWM step down (buck) controller.

Features

- Up to 6W Boost Output Providing Up to 18V
- 1.8V or 3.3V Regulator Provides 500mA with External NPN Transistor
- One Positive-Gate Voltage Regulator Capable of Delivering 20mA at 28V
- One Negative-Gate Voltage Regulator
- 2.2MHz Switching Operation
- Flexible Stand-Alone Sequencing
- True Shutdown Boost Converter
- Internal Soft-Start

- Overtemperature Shutdown
- -40°C to +105°C Operation
- AEC-Q100 Qualified

Multi-Channel Power Management ICs

The XR77128 from Exar is a quad-channel digital Pulse Width Modulated (PWM) step-down (buck) controller (Fig. 8-23). A wide 4.75V to 5.5V and 5.5V to 25V input voltage range allows for single supply operation from standard power rails.

With integrated FET gate drivers, two LDOs for standby power, and a 105kHz to 1.23MHz independent channel-to-channel programmable constant operating frequency, the XR77128 reduces overall component count, solution footprint, and optimizes conversion efficiencies. A selectable digital Pulse Frequency Mode (PFM) capable of better than 80% efficiency at light current load and low operating current allow for portable and Energy Star compliant applications. Each XR77128 channel's output voltage is individually programmable down to 0.6V with a resolution of 2.5mV, and is configurable for precise soft start and soft stop sequencing, including delay and ramp control.

The XR77128 operations are fully controlled via a SMBus-compliant I2C interface, allowing for advanced local and/or remote reconfiguration and full performance monitoring and reporting as well as fault handling.

Built-in independent output Over-Voltage, Over-Temperature, Over-Current, and Under-Voltage Lockout protections insure safe operation under abnormal operating conditions.

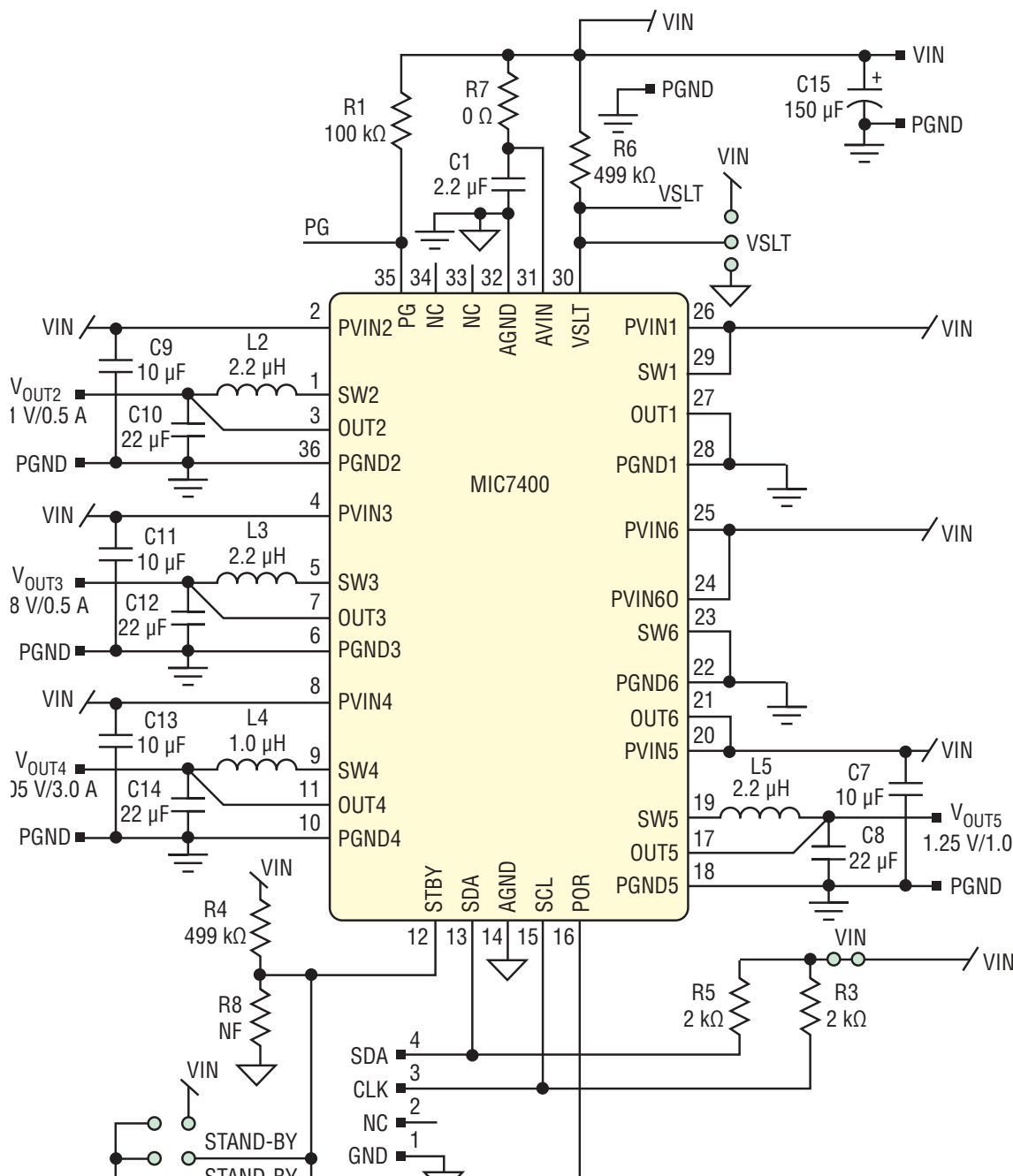

8-24. Micrel's MIC7400 is a multi-channel power supply with internal EEPROM.

MIC7400

The MIC7400 from Micrel is a multi-channel power supply with internal EEPROM (Fig. 8-24). It offers software-configurable soft-start, sequencing and digital voltage control (DVC) that minimizes PC board area. MIC7400 buck regulators are adaptive on-time synchronous step-down dc-dc regulators that operate from a 2.4V to 5.5V input range.

IC Features

- Five independent synchronous buck converters up to 3A
- One independent non-synchronous boost converter to 200mA and 70 μ A quiescent current
- 200 μ A quiescent current with all regulators on
- 93% peak buck efficiency, 85% typical efficiency at 1 mA
- 2.0MHz boost switching frequency
- 1.3 MHz buck operation in continuous mode
- Thermal shutdown and current limit protection

Programmable features

- Buck output voltage: 0.8V to 3.3V in 50 mV steps
- Boost output voltage: 7.0 to 14V in 200 mV steps
- Power on reset: 2.25V to 4.25V in 50 mV steps
- Power on reset delay: 5ms to 160ms in 5ms steps
- Power-up sequencing: 6 time slots
- Power-up sequencing delay: 0ms to 7ms in 1ms steps
- Soft-start: 4 μ s to 1024 μ s per step
- Buck current limit threshold: 1.1A to 6.1A in 0.5A steps
- Boost current limit threshold: 1.76A to 2.6A in 0.12A steps
- Boost pull-down: 37mA to 148mA in 37mA steps
- Buck pull-down: 90 Ω
- Buck standby output voltage programmable
- Boost standby output voltage programmable
- Global power good masking 

Related Articles

1. *Op Amps Add Precision and Save Space*, [powerelectronics.com](#), October 2013.
2. *Sam Davis, Third Generation Digital Signal Controllers Boost Digital Power Conversion Performance*, [powerelectronics.com](#), June 2015.
3. *Robinson Law, SiC MOSFET Gate Drive Optocouplers*, [powerelectronics.com](#), June 2014.
4. *Sam Davis, Energy Harvesting Employs Low Quiescent Current, Multi-Mode PMIC*, [powerelectronics.com](#), August 2013.
5. *Sam Davis, PMIC Integrates Multiple LDOs, Buck Controllers/Regulators for Portable Systems*, [powerelectronics.com](#), August 2013.
6. *Sam Davis, High Efficiency PoE++ PD Controllers Deliver up to 90W*, [powerelectronics.com](#), November 2012.
7. *Sam Davis, Isolated 12-Port Power over Ethernet PSE Controller Chipset*, [powerelectronics.com](#), June 2011.
8. *Sam Davis, PoE+ Attracts Compliant ICs*, [powerelectronics.com](#), January 2010.
9. *Sam Davis, Zero IQ IC Protects Against Reverse Polarity Inputs*, [powerelectronics.com](#), November 2015.
10. *Sam Davis, Three ICs Collaborate to Control Power for Intel's New 6th Gen. Processor*, [powerelectronics.com](#), October 2015.
11. *DrMOS Power Module*, [powerelectronics.com](#), August 2014.
12. *Sam Davis, All-SiC, High-Frequency Power Module*, [powerelectronics.com](#), February 2013.
13. *Sam Davis, A Look at Voltage Reference ICs*, [powerelectronics.com](#), September 2011.
14. *Sam Davis, Back to Basics: Power Management Impacts All Electronic Systems*, [powerelectronics.com](#), January, 2010.
15. *Sam Davis, Energy-Efficient Analog Devices Fit Auto Applications*, [powerelectronics.com](#), November 2008.

 [BACK TO TABLE OF CONTENTS](#)



CHAPTER 9:

BATTERY-POWER

MANAGEMENT ICs

Use of battery-powered systems have expanded as consumers have migrated to portable phones, MP3 players, digital cameras, and more. One reason for this growth has been the availability of batteries and power-management ICs that provide the required support for increasingly complex electronic systems. Fig.

9-1 shows the basic power-management subsystem employed in a battery-based system.

To be effective, these power-management subsystems must:

- Minimize battery size and weight while maximizing available run time.
- Provide the appropriate regulated output voltage over the specified input voltage range and load current.
- Minimize overall space and weight for associated components.
- Minimize heat dissipation to eliminate the need for sophisticated thermal management that adds size, weight, and cost.
- Allow a circuit-board layout that minimizes EMI.
- Maximize system reliability.

Battery Selection

To meet these design objectives, the power-management subsystem design begins with the battery, which may be a non-rechargeable primary battery or a rechargeable secondary battery. Primary battery examples are alkaline and lithium metal cells. Popular rechargeable batteries are nickel cadmium (NiCd), nickel-metal hydride (NiMH), lithium-ion (Li-ion), and lithium-polymer (Li-pol).

Lithium-ion batteries have the greatest electrochemical potential and the highest energy density per weight. The

Li-ion battery is safe, provided certain precautions are met when charging and discharging. Li-ion energy density is about twice that of the standard NiCd. Besides high capacity, the load characteristics are reasonably good and behave similarly to the NiCd in terms of discharge characteristics. Its relatively high cell voltage (2.7V to 4.2V) allows one-cell battery packs.

Exercise caution when handling and testing Li-ion batteries. Do not short-circuit, overcharge, crush, drop, mutilate, penetrate, apply reverse polarity, expose to high temperature, or disassemble. Use the Li-ion battery with its designated protection circuit.

The Li-pol battery differs from the Li-ion type in its fabrication, ruggedness, safety, and thin-profile geometry. Unlike the Li-ion, the Li-pol has minimal danger of flammability because it does not use a liquid or gelled electrolyte like the Li-ion. The Li-pol has simpler packaging and a lower profile than the conventional Li-ion battery.

Battery-Charger ICs

Battery chemistries have unique requirements for their charge technique, which is critical for maximizing capacity, cycle life, and safety. Linear topology works well in applications with low-power (e.g., one- or two-cell Li-ion) battery packs that are charged at less than 1A. However, switch-mode topology is better suited for large (e.g., three or four series Li-ion or multiple NiCd/NiMH) battery packs that require charge rates of 1A and above. Switch-mode topology is more efficient and minimizes heat generation during charging, but can produce EMI if not packaged properly.

The charge and discharge capacity of a secondary battery is in terms of “C,” given as ampere-hours (Ah).

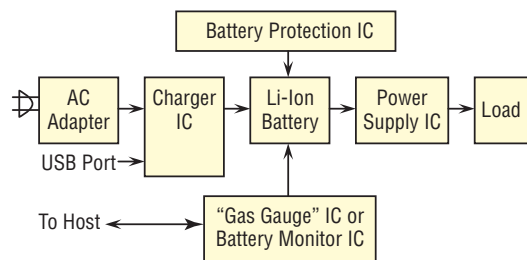

9-1. A typical battery-based power-management subsystem consists of single or multiple-function ICs.

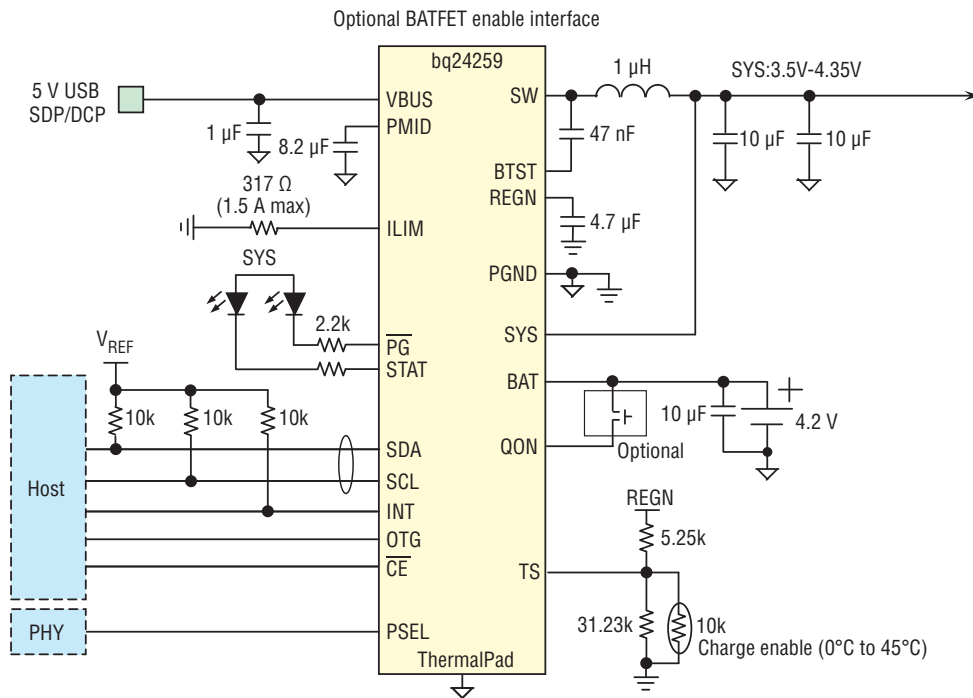

9-2. Texas Instruments' Bq24259 is a switch-mode battery-charge management and system power-path management IC for one-cell Li-ion and Li-polymer batteries.

The actual battery capacity depends on the C-rate and temperature. Most portable batteries are rated at 1C. A discharge of 1C draws a current equal to the rated capacity, that is, a battery rated at 1000mAh provides 1000mA for one hour if discharged at 1C rate.

Li-ion batteries have a higher voltage per cell, tighter voltage tolerance, and the absence of trickle or float charge when reaching full charge. Charge time for Li-ion batteries charged at a 1C initial current is about three hours. Full charge occurs after reaching the upper voltage threshold and the current drops and levels off at about 3% of the nominal charge current. Increasing Li-ion charge current has little effect on shortening the charge time. Although it reaches the voltage peak faster with higher current, the topping charge will take longer. Li-ion batteries cannot absorb overcharge, which can cause the cell to overheat. Li-ion constant-current-constant-voltage (CCCV) chargers are important to get the maximum energy into the battery, without overvoltage.

Performance and longevity of rechargeable batteries depends on the quality of the charger IC. One type of charger IC (used only for NiCd) applies a fixed charge rate of about 0.1C (one tenth of the rated capacity). A faster charger takes three to six hours with a charge rate of about 0.3C.

A charger for NiMH batteries could also accommodate NiCds, but not vice versa because a NiCd charger could overcharge a NiMH battery. Lithium-based chargers

require tighter charge algorithms and voltages. Avoid a charge rate over 1C for lithium battery packs because high currents can induce lithium plating. With most lithium packs, a charge above 1C is not possible because the protection circuit limits the amount of current the battery can accept.

Bq24259

The bq24259 from Texas Instruments is a switch-mode battery charge-management and system-power-path management device for a one-cell Li-Ion and Li-polymer battery (Fig. 9-2). Its low-impedance power path optimizes switch-mode operation efficiency, reduces battery charging time, and extends battery life during discharging phase.

The IC supports 3.9 V to 6.2 V USB input sources, including a standard USB host port and USB charging port with 6.4 V overvoltage protection. It also supports USB 2.0 and USB 3.0 power specifications with input current and voltage regulation.

The power-path management regulates the system slightly above battery voltage, but does not drop below 3.5 V minimum system voltage (programmable). With this feature, the system keeps operating even when the battery is completely depleted or removed. When the input source current or voltage limit is reached, the power-path management automatically reduces the charge current to zero and then discharges the battery until the system power requirement is met. This supplement-mode operation keeps the input source from getting overloaded.

The IC initiates and completes a charging cycle when host control is not available. It automatically charges the battery in three phases:

1. Pre-conditioning
2. Constant current
3. Constant voltage

In the end, the charger automatically terminates when the charge current is below a preset limit in the constant voltage phase. Later on, when the battery voltage falls below the recharge threshold, the charger will automatically start another charging cycle.

Safety features for battery charging and system operation include:

- Negative thermistor monitoring
- Charging safety timer

- Overvoltage protection
- Overcurrent protection

The thermal regulation reduces charge current when the junction temperature exceeds 120°C (programmable). An output reports the charging status and any fault conditions. And the IC immediately notifies host when fault occurs.

MAX8900

Maxim Integrated's **MAX8900** is a high-frequency switch-mode charger for a 1-cell Li+ or Li-Poly battery (Fig. 9-3). It delivers up to 1.2A to the battery from 3.4V to 6.3V (MAX8900A/MAX8900C) or 3.4V to 8.7V (MAX8900B). The 3.25MHz switch-mode charger is ideally suited to small portable devices such as headsets and ultra-portable media players because it minimizes component size and heat.

The MAX8900 is protected against input voltages as high as +22V and as low as -22V. Battery protection features include low-voltage prequalification, charge-fault timer, die-temperature monitoring, and battery temperature monitoring. The battery temperature monitoring adjusts the charge current and termination voltage as described in the JEITA (Japan Electronics and Information Technology Industries Association) specification for safe use of secondary Li+ batteries.

Charge parameters are adjustable with external components. An external resistance adjusts the charge current from 50mA to 1200mA. Another external resistance adjusts the prequalification and done-current thresholds from 10mA to 200mA. The done-current threshold is very accurate, achieving $\pm 1\text{mA}$ at the 10mA level. The charge timer is adjustable with an external capacitor.

A proprietary hysteretic-current PWM control scheme ensures high efficiency, fast switching, and physically tiny external components. Inductor ripple current is internally set to provide 3.25MHz. At very high duty factors, when the input voltage is lowered close to the output voltage, the steady-state duty ratio does not allow 3.25MHz operation because of the minimum off-time. The controller then provides minimum off-time, peak current regulation. Similarly, when the input voltage is too high to allow 3.25MHz operation due to the minimum on-time, the controller becomes a minimum on-time, valley current regulator.

To prevent input current transients, the rate of change of the input current (di/dt) and charge current is limited. When the input is valid, the charge current ramps from 0mA to the fast-charge current value in 1.5ms. Charge current also soft-starts when transitioning from the prequalification state to the fast-charge state. There is no di/dt limiting when transitioning from the done state to the fast-charge state.

Battery-Monitor ICs

Portable systems are sensitive to usable battery life. This is particularly important for computers where a loss of power could mean a loss of stored data. Therefore, it is useful to provide a real-time indication of remaining battery life. One approach is a battery monitor that accumulates battery data and transmits it to a host processor. Another approach is a “gas gauge” that displays battery life within its associated equipment.

Battery monitors are mixed-signal ICs that include digital memory and registers that store battery data. Analog circuits include temperature sensors and amplifiers, as well as interface circuits. To measure battery current, a monitor usually includes either an internal or external current sense resistor. Voltage and current measurements are usually via an on-chip A/D converter.

One solution to this battery-sensitive situation is to include a means for providing a real-time indication of remaining battery life to the system user. Battery monitors are actually data-acquisition systems that accumulate data related to battery parameters and then transmit the battery data to a host processor.

Battery monitors are mixed-signal ICs that incorporate both analog and digital circuits. These monitors include one or more types of digital memory and special registers to hold battery data. Analog circuits include temperature sensors and amplifiers, as well as some interface circuits.

To measure battery current, the monitors usually include

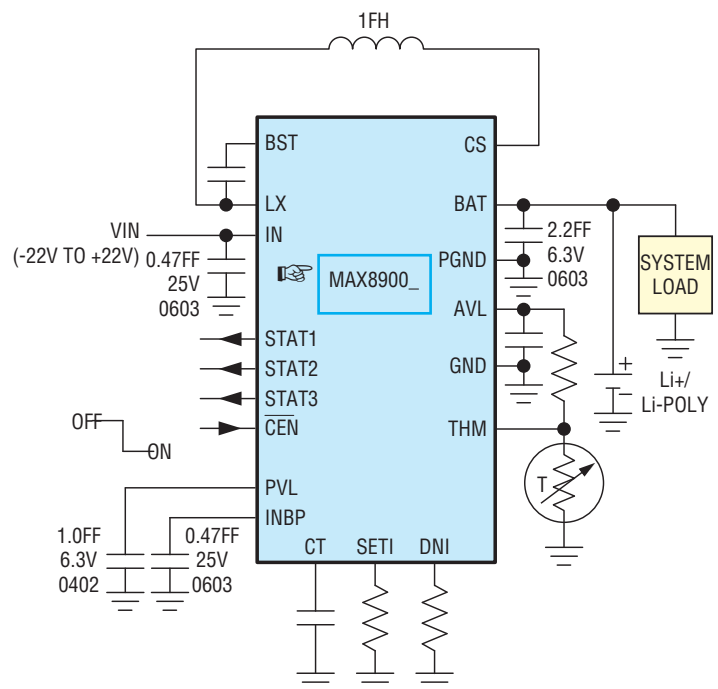

9-3. Maxim's **MAX8900** is a high-frequency switch-mode charger for a one-cell Li+ or Li-polymer battery.

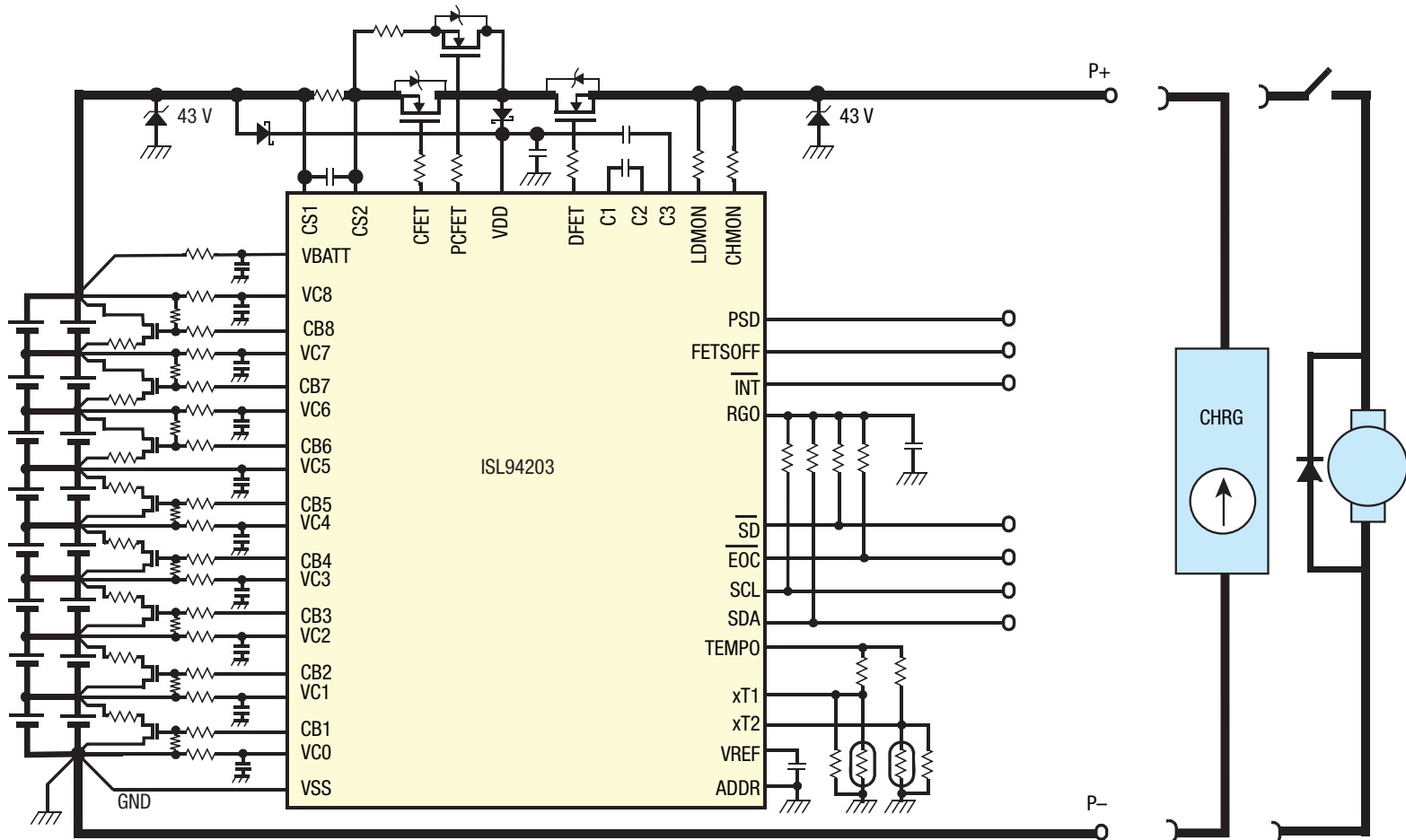

9-4. Intersil's ISL94203 is a stand-alone battery-pack monitor that provides monitor and protection functions.

either an internal or external current sense resistor. Voltage and current measurements are usually via an on-chip A/D converter.

Among the monitored battery parameters are overcharge (overvoltage), overdischarge (undervoltage), and excessive charge and discharge currents (overcurrent, short circuit), information of particular importance in Li-ion battery systems. In some ways a battery monitor assumes some of the functions of a protection circuit by protecting the battery from harmful overcharging and overcurrent conditions.

Intersil's ISL94203 is a stand-alone battery-pack monitor that provides monitor and protection functions without using an external microcontroller (Fig. 9-4). The IC locates the power-control FETs on the high side with a built-in charge pump for driving N-Channel FETs. The current sense resistor is also on the high side.

Power is minimized in all areas, with parts of the circuit powered down a majority of the time, to extend battery life. At the same time, its RGO output stays on, so that any connected microcontroller can remain on most of the time.

The ISL94203 includes:

- Eight-cell voltage monitors that support Li-ion CoO₂, Li-ion Mn₂O₄ and Li-ion FePO₄ chemistries

- Input level shifter to enable monitoring of battery stack voltages
- 14-bit ADC converter, with voltage readings trimmed and saved as 12-bit results
- 1.8V voltage reference (0.8% accurate)
- 2.5V regulator, with the voltage maintained during sleep
- Automatic scan of the cell voltages; overvoltage, undervoltage, and sleep voltage monitoring
- Selectable overcurrent detection settings
- 8 discharge overcurrent thresholds
- 8 charge overcurrent thresholds
- 8 short circuit thresholds
- 12-bit programmable discharge overcurrent delay time
- 12-bit programmable charge overcurrent delay time
- 12-bit programmable short-circuit delay time
- Current-sense monitor with gain that provides the ability to read the current-sense voltage
- Second external temperature sensor for use in monitoring the pack or power FET temperatures
- EEPROM for storing operating parameters and a user area for general purpose pack information
- Cell balancing uses external FETs with internal state machine or external microcontroller

Battery Gas-Gauge ICs

The gas-gauge IC is usually found within the battery pack. Because specific inputs on the gas-gauge IC connect directly to the battery, those inputs must consume very little power. Otherwise, battery life will be reduced during long storage periods. Initially, the battery must be fully charged and the counters and registers set to states consistent with a fully charged battery. As discharge occurs, the gas-gauge IC tracks the amount of charge removed from the battery.

Most battery gas gauges compensate for both temperature and charge/discharge rate. Typically, it displays the available charge on LEDs and also can send the charge data to an external processor via an I/O port. The LED presentation usually consists of five or six segments of a “thermometer” display. To conserve battery power, the display is only activated at the user’s command. At full charge, all the LED segments are lit. As battery life decreases, the gas-gauge IC extinguishes successive segments on the thermometer display.

The gas-gauge IC calculates the available charge of the battery while compensating for battery temperature because the actual available charge is reduced at lower temperatures. For example, if the gas-gauge IC indicates that the battery is 60% full at 25°C, then the IC indicates 40% full when cooled to 0°C, which is the predicted available charge at that temperature. When the temperature returns to 25°C, the displayed capacity returns to 60%. This ensures that the indicated capacity is always conservatively representative of the charge available for use under the given conditions.

Depending on the battery type, the gas-gauge IC also adjusts the available charge for the approximate internal self-discharge of the battery. It adjusts self-discharge based on the selected rate, elapsed time, battery charge level, and temperature. This adjustment provides a conservative estimate of self-discharge that occurs naturally and that is a significant source of discharge in systems that are not charged often or are stored at elevated temperatures.

The gas-gauge IC is usually packaged within the battery pack. Because specific inputs on the gas-gauge IC connect directly to the battery, those inputs must consume very little power. Otherwise, battery life will be reduced during long storage periods.

The battery gas gauge continuously compensates for both temperature and charge/discharge rate. Typically, it displays the available charge on LEDs and also can send the charge data to an external processor via an I/O port. The LED presentation usually consists of five or six segments of a “thermometer” display. To conserve battery

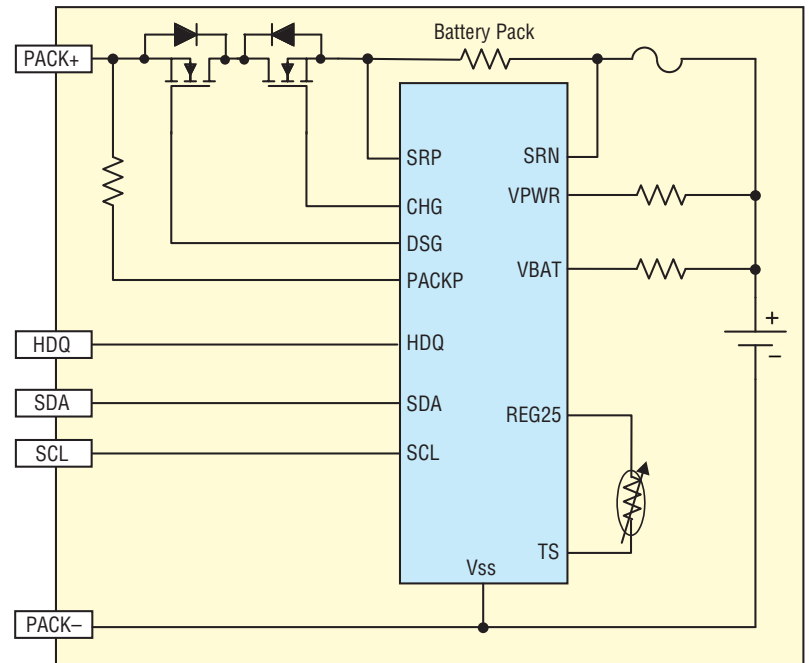

9-5. Texas Instruments' bq27741-G1 provides fuel gauging for single-cell Li-ion battery packs.

power, the display is only activated at the user’s discretion.

Battery gas-gauge ICs employ mixed-signal, analog, and digital circuits. One technique is to use analog circuits to monitor battery current by measuring the voltage drop across a low-value resistor (typically 20mΩ to 100mΩ) in series with the battery. This provides the charge input to the battery and the charge subsequently removed from the battery. Integrated over time, the scaled voltage drives internal digital counters and registers. The counters and registers track the amount of charge available from the battery, the amount of charge removed from the battery since it was last full, and the most recent count value representing “battery full.”

Bq27741-G1

Texas Instruments' bq27741-G1 Li-ion battery fuel gauge is a microcontroller peripheral that provides fuel gauging for single-cell Li-Ion battery packs (Fig. 9-5). The device requires little system microcontroller firmware development for accurate battery fuel gauging. The fuel gauge resides within the battery pack or on the system’s main board with an embedded battery (non-removable).

Cell information is stored in the fuel gauge in non-volatile flash memory. Many of these data flash locations are accessible during application development. They cannot, generally, be accessed directly during end-equipment operation. To access these locations, use individual commands, a sequence of data-flash-access commands.

The key to the high-accuracy gas-gauging prediction is

the proprietary Impedance Track algorithm. This algorithm uses cell measurements, characteristics, and properties to create state-of-charge predictions that can achieve less than 1% error across a wide variety of operating conditions and over the lifetime of the battery.

The fuel gauge provides:

- Hardware-based overvoltage
- Hardware-based undervoltage
- Overcurrent in charge or discharge
- Short-circuit protection

Information provided includes:

- Remaining battery capacity (mAh)
- State-of-charge (%)
- Run-time to empty (minimum)
- Battery voltage (mV) and temperature (°C)
- Vital parameters recorded throughout battery lifetime

Battery-Protector ICs

An added requirement for Li-ion battery packs is a protection circuit that limits each cell's peak voltage during charge and prevents the voltage from dropping too low on discharge. The protection circuit limits the maximum charge and discharge current and monitors the cell temperature. This protects against overvoltage, undervoltage, overcharge current, and overdischarge current in battery packs.

Ideally, the protection circuit should consume no current when the battery-powered system is turned off. However, the protector always consumes some small current. A single-cell rechargeable Li+ protection IC provides electronic safety functions required for rechargeable Li+ applications including protecting the battery during charge, protection of the circuit from damage during periods of excess current flow and maximization of battery life by limiting the level of cell depletion. Protection is facilitated by electronically disconnecting the charge and discharge conduction path with switching devices such as low-cost N-channel power MOSFETs.

Battery-Protection IC

The S-8240A Series monitors the voltage of the battery connected between VDD pin and VSS pin, the voltage

between VM pin and VSS pin to control charging and discharging (Fig. 9-6). When the battery voltage is in the range from overdischarge detection voltage (VDL) to overcharge detection voltage (VCU), and the VM pin voltage is in the range from charge overcurrent detection voltage (VCIOV) to discharge overcurrent detection voltage (VDIOV), the S-8240A Series turns both the charge and discharge control FETs on. This condition is called the normal status, and in this condition charging and discharging can be carried out freely.

The resistance between VDD pin and VM pin (RVMD), and the resistance between VM pin and VSS pin (RVMS) are not connected in the normal status.

When the battery voltage becomes higher than VCU

during charging in the normal status and the condition continues for the overcharge detection delay time (t_{CU}) or longer, the S-8240A Series turns the charge control FET off to stop charging. This condition is called the overcharge status.

The overcharge status is released in the following two cases.

1. In the case that the VM pin voltage is lower than VDIOV, the S-8240A Series releases the overcharge status when the battery voltage falls below overcharge release voltage (VCL).

2. In the case that the VM pin voltage is equal to or higher than VDIOV, the S-8240A Series releases the overcharge status when the battery voltage falls below VCU.

When the discharge is started by connecting a load after the overcharge detection, the VM pin voltage rises by the V_f voltage of the parasitic diode than the VSS pin voltage, because the discharge current flows through the parasitic diode in the charge control FET. If this VM pin voltage is equal to or higher than VDIOV, the S-8240A Series releases the overcharge status when the battery voltage is equal to or lower than VCU.

Battery Power-Supply ICs

Virtually all battery-based systems are intended for portable operation. As such, their power converters have requirements that dictate the associated configurations. This also means that the converter ICs should require very few external components and any that are used should be low-cost types. Also, to minimize size and weight, the

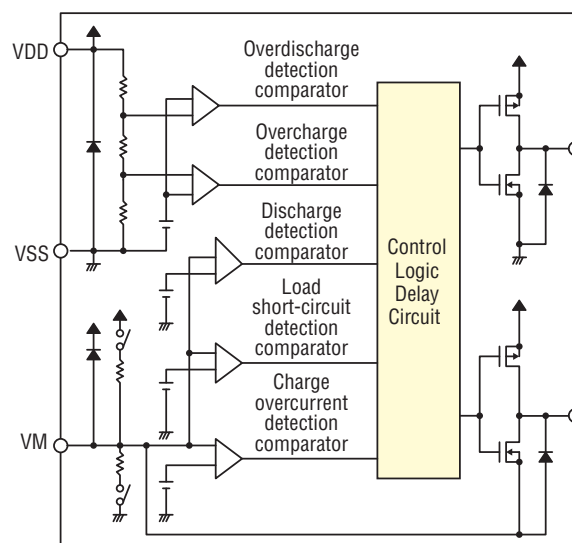

9-6. The S-8240A Series from S.I.I. monitors the voltage of the battery connected between VDD pin and VSS pin and the voltage between VM pin and VSS pin to control charging and discharging.

IC should be packaged in some form of BGA package. In addition, the application will determine what combination of buck, boost, or buck-boost functions will be available.

One tradeoff in selecting a converter IC is whether it employs external or on-chip power MOSFET switches. On-chip devices minimize external components, but have a tendency to increase the junction temperature and degrade thermal performance. Depending on the package employed, this could also reduce the current carrying capacity of the converter IC.

One design consideration is reducing power dissipated by the power converter, which in turn increases battery run time. Most converter ICs have a shutdown pin that disables the output voltage, cutting battery drain. This can be done in many systems that have a normal “sleep” mode. When the IC comes out of the shutdown mode, it has to do so without upsetting the system. Also available in most battery-based converter ICs is undervoltage lockout (UVLO) that shuts down the power supply if the input voltage drops below a specific threshold. Therefore, if the battery output voltage drops too far, the supply will shut down. Another characteristic of these converter ICs is protection against overcurrent, which protects both the controller IC and the system components. This is accomplished by sensing current to the load and cutting power

for an overload condition.

An important design consideration is minimizing the supply's power dissipation, which increases battery run time. This is aided by a shutdown pin that disables the power supply, cutting battery drain. When the IC comes out of the shutdown mode, it has to do so without generating a transient that upsets the system.

Also available in most battery-based supply ICs is undervoltage lockout (UVLO) that disables the power supply if the battery output voltage drops too low.

Most of these supply ICs protect against overcurrent, which protects both the IC and system components. This involves a current sensor that monitors load current and cuts power for an overload.

For all switching power supplies, layout is an important design consideration, especially at high peak currents and high switching frequencies. If the layout is not carefully done, the supply IC could become unstable or produce EMI. This requires wide and short traces for the main current path and for the power ground tracks. The input capacitor, output capacitor, and the inductor should be placed as close as possible to the IC.

The feedback divider should be placed as close as possible to the control ground pin of the IC. In laying out the control ground, use short traces separated from the power ground traces.

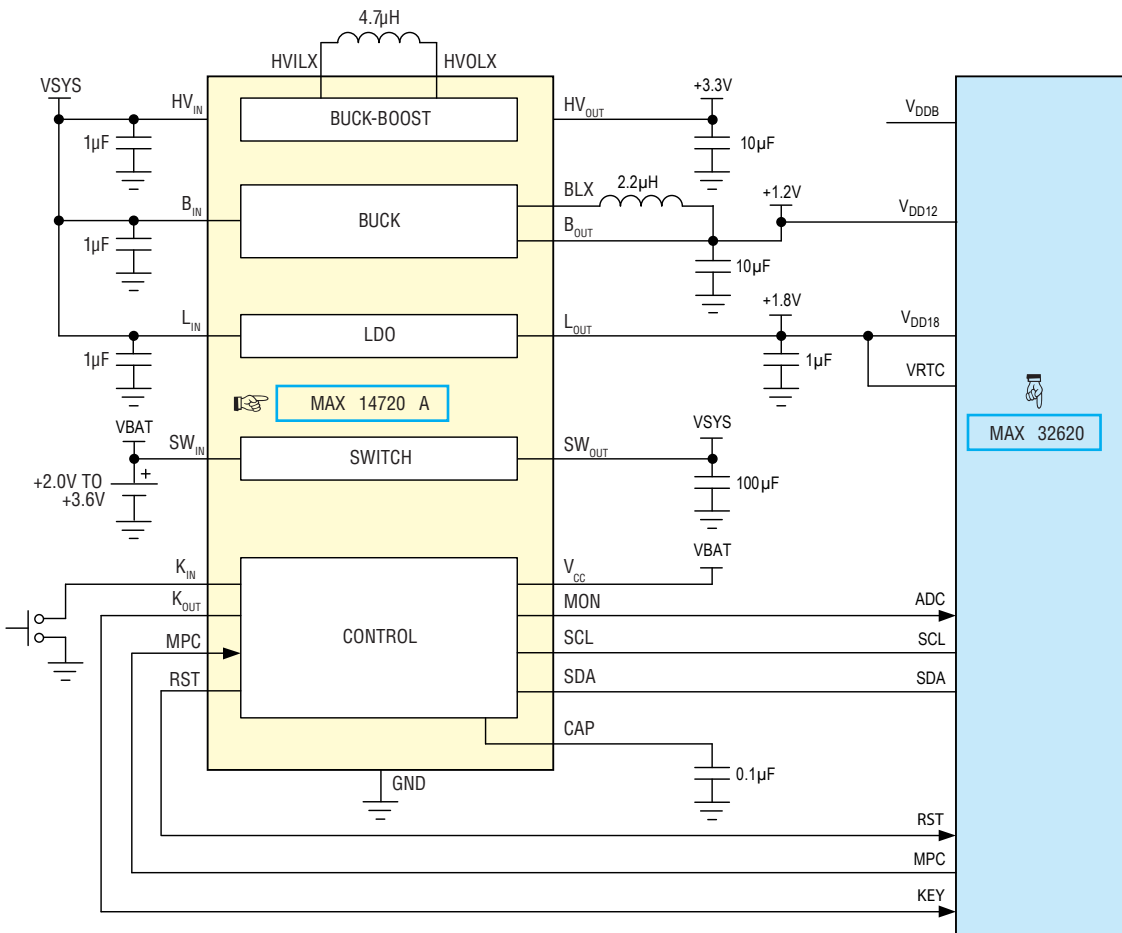

MAX14720

Maxim's **MAX14720** is a compact power-management solution for space-constrained, battery-powered applications where size and efficiency are critical (Fig. 9-7). This IC integrates a power switch, linear regulator, buck regulator, and buck-boost regulator.

The MAX14720 is intended to be the primary power-management device and is ideal for either non-rechargeable battery (coin-cell, dual alkaline)

9-7. Maxim's MAX14720 is a compact power-management solution that integrates a power switch, linear regulator, buck regulator, and buck-boost regulator.

applications or for rechargeable solutions where the battery is removable and charged separately. The device includes a button monitor and sequencer.

There are two programmable micro-IQ, high-efficiency switching converters: a buck-boost regulator and a synchronous buck regulator. These regulators feature a burst mode for increased efficiency during light-load operation.

A low-dropout linear regulator has a programmable output. It can also operate as a power switch that can disconnect the quiescent load of system peripherals.

This IC also includes a power switch with battery-monitoring capability. The switch can isolate the battery from all system loads to maximize battery life when not operating. It is also used to isolate the battery-impedance measurements. This switch can also operate as a general-purpose load switch.

The MAX14720 includes a programmable power con-

troller that allows the device to be configured either for use in applications that require a true off state or for always-on applications. This controller provides a delayed reset signal, voltage sequencing, and customized button timing for on/off control and recovery hard reset.

This IC is available in a 25-bump, 0.4mm pitch, 2.26mm x 2.14mm wafer-level package (WLP) and operate over the -40°C to +85°C extended temperature range.

Multi-Function Battery Power-Management ICs

These ICs perform multiple functions in a battery-based system. Among these functions are battery charging, dc-dc conversion, battery protection, battery monitoring, and power-source selection.

For example, an IC integrates PWM power control for charging a battery and converting the battery voltage to a regulated output. Also, it can simultaneously charge the battery while powering a system load from an unregulated ac wall adapter. Combining these features into a single IC produces a smaller area and lower-cost solution compared to presently available multi-IC solutions. The IC shares the discrete components for both the battery charger and the dc-dc converter, minimizing size and cost relative to dual controller solutions. Both the battery charger and dc-dc converter use a current-mode flyback topology for high efficiency and excellent transient response. Optional Burst Mode operation and power-down mode allow power density, efficiency, and output ripple to be tailored to the application.

The IC provides a complete Li-Ion battery charger with charge termination timer, preset Li-Ion battery voltages, overvoltage and undervoltage protection, and user-programmable constant-current charging. Automatic battery recharging, shorted-cell detection, and open-drain C/10 and wall-plug detect outputs are also provided. User programming allows NiMH and NiCd battery chemistries to be charged as well.

TPS65010

Texas Instruments' TPS65010 is an integrated power and battery management IC for applications powered by one Li-ion or Li-polymer cell, and which require multiple power rails (Fig. 9-8). **The power source components include:**

- 1A step-down converter for I/O and peripheral components (VMAIN)
- 400mA, 90% efficient step-down converter for processor core (VCORE)
 - 2x 200mA LDOs for I/O and peripheral components, LDO enable through bus
- Serial interface compatible with I2C, supports 100kHz, 400 Hz operation

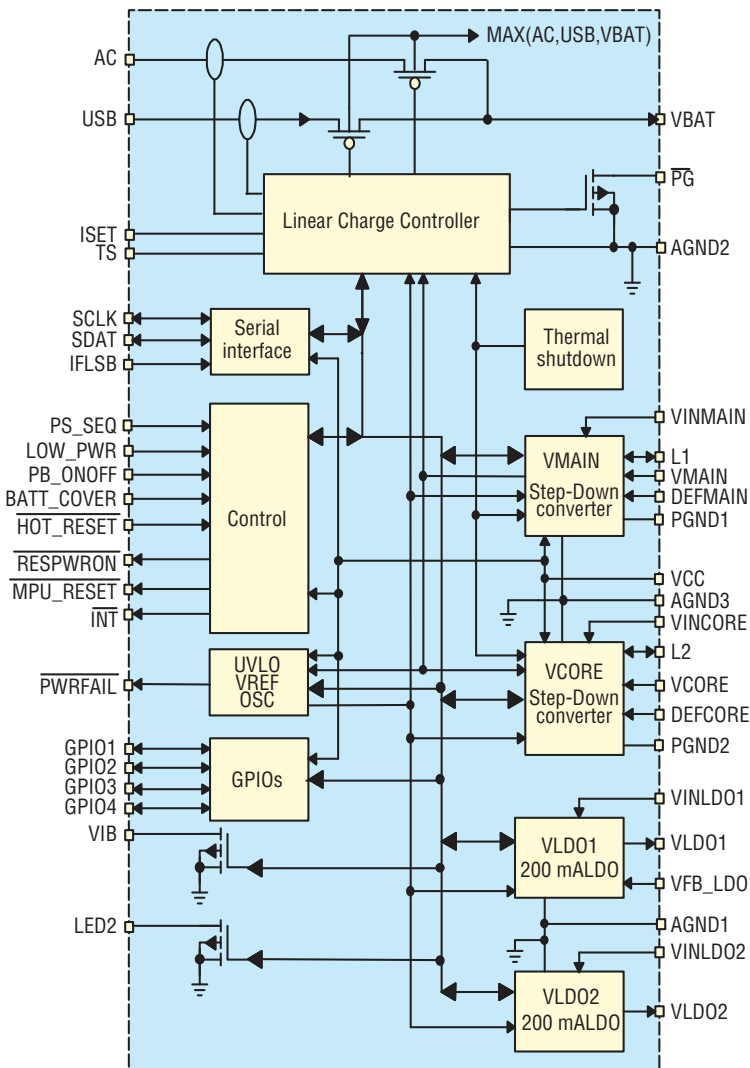

9-8. Texas Instruments' TPS65010 is an integrated power-supply and battery-management IC.

- 70µA quiescent current
- 1% reference voltage
- Thermal shutdown protection

The TPS65010 charger automatically selects the USB port or the ac adapter as the power source for the system. In the USB configuration, the host can increase the charge current from the default value of maximum 100 mA to 500 mA through the interface. In the ac-adapter configuration, an external resistor sets the maximum value of charge current. The battery is charged in three phases:

- Conditioning
- Constant current
- Constant voltage

Charge is normally terminated based on minimum current. An internal charge timer provides a safety backup for charge termination. The TPS65010 automatically restarts the charge if the battery voltage falls below an internal threshold. The charger automatically enters sleep mode when both supplies are removed. 

Related Articles

1. *Seste Dell' Aera, Advancements in Batteries and Power Electronics Are Poised to Change the Electrical Landscape, powerelectronics.com, July 2015.*
2. *Bob Richard, Lithium Battery Shipments Face Challenges as Regulators and Airlines Impose Additional Restrictions, powerelectronics.com, April 2015.*
3. *K.C. Yang, Battery Simulator Provides Mobile Insurance, powerelectronics.com, January 2016.*

4. *Rajakrishnan Radjassamy, Gas Gauge IC Monitors Lead-Acid Battery State-Of-Health, State-Of-Charge, powerelectronics.com, June 2013.*
5. *Jerry Zheng, Real Time Waveform Analysis Helps Optimize Charger Performance, powerelectronics.com, March 2011.*
6. *Sam Davis, Power-Tracking Battery-Charger IC Supports Solar-Power Systems, powerelectronics.com, September 2009.*
7. *Sam Davis, Charger ICs Reflect Battery Requirements, powerelectronics.com, February 2009.*
8. *Terry Cleveland, Battery Charger Adapts to Multiple Chemistries, powerelectronics.com, July 2008.*
9. *Sam Davis, System-on-a-Chip IC Enables Power Bank to Extend Life of Battery-Powered Devices, powerelectronics.com, December 2013.*
10. *Sam Davis, Mixed-Signal ICs Manage Battery-Based Power Supplies, powerelectronics.com, August 2012.*
11. *Bertrand Renaud, Thermal Dissipation for DC-DC Conversion in Portable Designs, powerelectronics.com, January 2010.*
12. *Sam Davis, Battery Management IC Protects High Current Loads, powerelectronics.com, September 2011.*
13. *Jeff VanZwol, Designing Battery Packs for Thermal Extremes, powerelectronics.com, July 2006.*
14. *Jason Cole, Characterizing a Battery for use with a Battery Fuel Gauge, powerelectronics.com, July 2011.*
15. *Roger Allan, Power Management ICs Improving Rechargeable Battery Lifetimes, powerelectronics.com, April 2011.*

 **BACK TO TABLE OF CONTENTS**