

# Electronic Design®

# LIBRARY



FOCUS ON:  
**BOB PEASE**  
**ON ANALOG** VOL. 2

A compendium of technical articles  
from legendary *Electronic Design*  
engineer Bob Pease



# CONTENTS

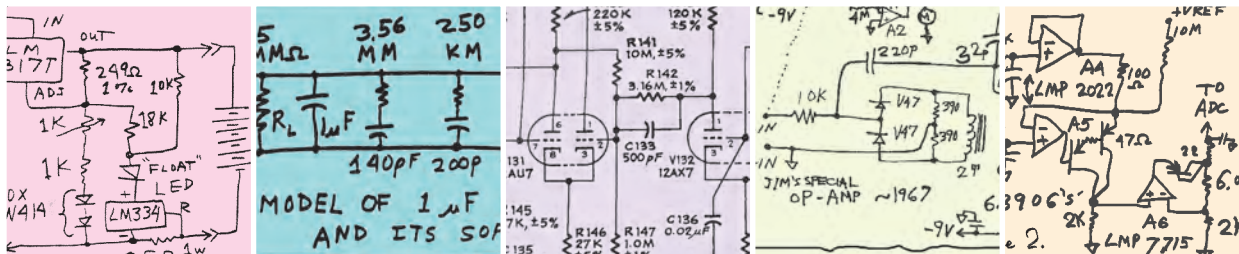

- 2** | Welcome
- 3** | What's All This Battery-Powered Stuff, Anyhow?
- 10** | What's All This Battery-Charging Stuff, Anyhow?
- 19** | What's all this Soakage Stuff, Anyhow?
- 26** | What's All This Future Stuff, Anyhow?
- 29** | What's All This Ripple Rejection Stuff, Anyhow? (Part 1)
- 32** | What's All This Ripple Rejection Stuff, Anyhow? (Part 2)
- 35** | What's All This One-Transistor Op-Amp Stuff, Anyhow?
- 38** | What's All This Bridge Amplifier Stuff, Anyhow?
- 41** | What's All This Best Amplifier Stuff, Anyhow?
- 44** | What's All This Profit Stuff, Anyhow?
- 51** | More Resources From *Electronic Design*

## EDITORIAL



*Welcome to the second volume in our Bob Pease e-book series.*

WE ALL REMEMBER BOB PEASE FONDLY—for his analog design expertise as well as his sense of humor. Just some months ago, someone in the industry who worked with Bob talked about how he would always say that an engineer’s most valuable tool was a soldering iron. We were lucky he shared his wit and knowledge with us for years with his special column for Electronic Design, “Pease Porridge.”

In this second Pease e-book, we’ve gathered some columns on topics ranging from battery power and charging to soakage. We also feature Bob’s thoughts on the future, where he shares his thoughts on early fuel cells, nuclear power, and what will happen to oil-shale—thoughts that are more relevant than ever, given the advent of solar and wind power and near-future dreams of energy harvesting to

power homes, offices, and cities.

In “*What’s All This Profit Stuff, Anyhow?*,” Bob gives a history lesson dating back to the invention of the P2 amplifier at George A. Philbrick Researches in the 1960s. Amplifiers were of course a favorite topic of Bob’s, so we’ve included columns on bridge amplifiers, one-transistor op amps, and what constitutes the “best” amplifier. Rounding out this collection are articles on ripple rejection and soakage.

He certainly had his own way of discussing topics. The article about “soakage,” for example, was so named because Bob considered “*dielectric absorption of capacitors*” just too long a phrase. In addition to his practical and efficient nature when addressing engineering topics, Bob brought his own life and perspective to his columns. In this one, he explains to a “concerned friend” that “the ‘expert’ who thinks that speaker cables will sound ‘different’ or ‘better’ if they are made with low-DA materials will probably have a very thin chance of telling any difference.”

He goes on to explain how he underscored his point to his friend: “*I told him this relevant Aesop’s Fable: Do you know the Celluloid Cat? That is the Celluloid Cat being chased by the Asbestos Dog. Well, that ‘expert’ has about as good of a chance of hearing any difference, as the Celluloid Cat being chased by the Asbestos Dog through the Fires of Hell.*” Years after he is gone, he is still making us smile. As Bob would say, “*All for now.*”

NANCY FRIEDRICH, Former Content Director  
Electronic Design



# What's All This Battery-Powered Stuff, Anyhow

*Originally published March 4, 1993*

**W**hen I went hiking in Nepal in 1989, obviously I should have taken along a camcorder. But I didn't, and none of the other guys on the trek did either. I did bring a good 35mm camera and a small tape recorder, because I was well warned that many things in Nepal are very photogenic. I shot over 1000 slides. But, if I go on a trek like that again, a camcorder would be a very good thing to bring along. (I would still bring a small 35-mm camera in my pocket, for landscapes and pictures with higher resolution than any TV).

But when I began to ponder the actualities, I realized that it would be very hard to get enough

## What's All This Battery-Powered Stuff, Anyway?

battery power to do even an hour a day of recording. So, when I bought a camcorder in 1991, I began planning how to bring the camera on a trek.

I bought the Sony TR-51 because it's quite compact and light at 1-3/4 lbs. (including strap but no case). It weighs less than my 35mm single-lens-reflex camera (Nikomat FTN, 2-1/2 lbs., including strap but no case), and it isn't much more bulky. If one had to carry a bulky old 1989 camcorder that weighed about 5—lbs.—well, I refuse to think about that.

I will presume that a small 8mm or similar compact camera is the right way to go. You can carry it easily and fire off a quick shot when you want. The TR-51 draws about 1 ampere from its 7-volt battery, about 7 watts.

Batteries... Sony's model NP-55 (about \$40) is good for 1 hour of steady recording, about 1 ampere-hour. But if you turn the camera on and off a lot, taking little snips of action and scenery, you're lucky if it lasts 40 minutes. Obviously, one of these batteries, fully charged, will barely last you about one day in a photogenic place like Nepal. The larger NP-77 (about \$60, 10 oz.) is good for almost double that amount, 1.8 ampere-hours. I have one NP-55 and one NP-77. So after the first 3 days in

the wilderness, away from ac power, I will have to invent some kind of battery charger....

It's possible to put a set of five AA cells in a tiny little \$50 battery box sold by Sony. But they're not effective energy-wise in terms of weight or cost.

You could rig up five alkaline D cells in an extension-cord battery pack. That would be four times more effective than AA cells from the standpoint of weight and cost vs. energy. But after several days, you would need more D cells. Not cheap nor light. I bought a set of five rechargeable, sealed lead-acid cells. These are heavy and cost-effective, and would keep you in business about five days—but then they would run out.

So I needed some kind of battery-charging scheme. Solar cells would be much too bulky, and maybe too fragile? They're also unreliable on a rainy or cloudy day, and not easy to use if you're hiking through a forest. I mean, it's not easy to mount them on top of your backpack. Note, most solar-cell panels will inherently put out ZERO current if any portion of the panel is in the shade! But I do plan to buy one and check it out.<sup>1</sup>

A gasoline-powered generator would be gross overkill. Remember, an NP-55 (about 1 ampere-hour × 7 V) is just

## What's All This Battery-Powered Stuff, Anyway?

7 watt-hours, which is only about 1% of a horsepower-hour of energy. So a 1-horsepower gasoline generator would be absurd.

Frank Goodenough suggested, could you rig up a little model airplane engine to a tiny generator? That's about the right amount of horsepower, perhaps 1/10 horsepower, and the weight would be reasonable. But they're not very efficient; they would guzzle lots of fuel if you ran one half-an-hour a day. And the noise would not be acceptable, even after you added a muffler. So I do not see a solution down that alley.

One other possibility is if there are any decent, fairly compact camcorders that draw a lot less than 6 watts. I haven't looked into that, but I don't foresee much chance here for a really significant energy saving.

I asked my friends at work, but nobody had any good ideas about battery-charging. I have seen a portable radio with Nicads and a hand-crank generator.<sup>2</sup> You crank it up for a couple minutes and then you can listen for a half-hour. But this radio obviously runs on a lot less than 6 watts—probably down near 0.06 watts. Even if you rigged it up for additional output to an external battery, it might not be at all suitable.

I spotted a little hand-crank generator, in an Edmund Scientific catalog, that could put out “10 V, 100 mA.” The price of \$48 was absurd, but I decided to try it. When it arrived, it was a cheap little motor with flimsy plastic gears in a light but flimsy plastic framework. If you cranked it fast, the gear ratio was barely adequate, so you could just barely get 7 volts. And if you wanted to get 100mA charged into a 7-volt battery, you had to crank almost at a frenzy. Bad investment. Not suitable for a battery charger.

Then a friend at work, Fran Hoffart, said he had a “gear motor.” It had a 12-volt motor with an integral 65:1 gear box that he had bought for a couple bucks at the Electronics Flea Market.<sup>3</sup> I put a long crank arm on its “output” shaft and tried cranking. At about 30 rpm, a leisurely 2 seconds per revolution, I was able to get 200 to 400 mA into a 7-volt battery pack. Not bad! The gear motor weighs 1.2 lbs. (including crank and wires), which is not a trivial amount to add on top of your 45-lb. pack frame. But the alternative is to carry a 1.7-lb. camcorder that you can't use because its batteries are dead.

I strengthened the crank handle, hooked up some connectors and a little strap-on socket for the battery, and paid Fran \$5 for the gear motor. Then off we

## What's All This Battery-Powered Stuff, Anyway?

went on an 8-day backpack trip in the Sierras. To be honest, it took a lot of cranking to get much charge. I started the trip with both batteries fully charged, and after 4 days, both were pretty low. Still, with an hour of cranking, I could get an honest 1/3 ampere-hour into a battery, and that would be good for 15 minutes of intermittent recording.

And we always had a quiet hour in the evening when we would be sitting around sipping juices and nibbling snacks. So I could easily put in my hour a day of cranking, and that was enough to get some coverage of a day's events. I also was able to con my friends into helping out with the cranking. After all, how could I record their antics on tape if they didn't help bring up the charge on the batteries? So they helped, and grinned.

Eventually, I installed a good knob on the crank so I could easily crank at a good torque for a long time (just turning over the crank easy would put 100 mA into the battery, but if you want to get a good 300-mA output you have to crank with quite a bit of force). I rigged a spare piece of cord so the torque from cranking could be carried by a long lever arm and the cord itself to my foot (as I sat cranking), or to my neck (as I ambled along a trail). This cut out a

great deal of the effort needed to hang onto the motor as I cranked. I found I could crank as I walked along easy trails. But if I had to do any serious hiking, it would be pretty hard to crank at the same time.

Still, if I went on a trek, I could crank an hour or two per day and keep my batteries charged up pretty well so that I could record a few dozen minutes every day. If I went to Nepal, I would pay one of the porters a few rupees to crank for an hour every evening. If I go backpacking with friends, I can get my friends to chip in a few minutes, just for a lark. And they did enjoy helping on my recent trip, just like Tom Sawyer got his friends to help him white-wash the fence. SO, I think I have a handle (literally) on how to drag along enough batteries for a big trek. I would need 3 or 4 batteries, and a couple of chargers, and I'd have to put in some of my spare time. I might even have to do some cranking while I hiked on easy trails. But it WOULD work.

Where would you buy one of those gear-motor sets? Well, the one I got is made by The Pittman Co.,<sup>4</sup> and is rated at 12-volt dc with a 65:1 gear ratio. I peeked inside, and the gears do seem well-lubricated and well-designed for industrial service. I got a catalog, and this

## What's All This Battery-Powered Stuff, Anyway?

model is still available. The specs make sense. But the amount of torque I was putting in was excessive for the output gears.

So I ordered a similar gear motor with 38:1 gear ratio, GM9413-38:1. This is about as small and light as you can get for a gear motor that will put out 300 mA at 7 volts—anything smaller than that could not handle the torque (175 inch-ounces at 50 rpm) or the amperes.

What about cassettes? The VHS-compact tapes only run 20 minutes, so you would use up a pretty big box of them on a 20-day trek. The 8mm cassettes are compact and can record for 120 or 150 minutes, so 10 of them would last for 20 days (at 1 hour per day) and that's the same size as 10 audio cassettes—not bad.

Rain-proofing.... If you're out hiking and rain begins, a plastic bag or two can keep your machine pretty dry. If you wanted to take some shots on a rainy day, and it's not too windy, you can carry an umbrella. I tried that, and I was delighted to find it worked quite well. Or, for about \$150, you can buy a camcorder raincoat that lets you shoot through an optically flat glass while the camera stays perfectly protected from the rain. You just put your hand up into that bag from below. For about \$350, you can

get a completely sealed version of a big heavy plastic bag with excellent water-proofing and an optically flat glass front panel, so you can take your camcorder diving with you down to 30 feet deep.

I'll list the outfit that sells these<sup>5</sup>, because many camera stores won't know where you can buy them. Still, \$150 is a lot to pay for a plastic bag. But it's better than getting your camera soaked or doused with salt spray. I just brought some plain plastic bags and a zip-lock plastic bag, and I put on an extra UV lens to protect the camera's front end.

This camera is small enough (7-1/4 in. × 4 in. × 3-1/4 in.) to fit into a small water-repellent "fanny pack," so I can easily strap it around my tummy and bring it just about anywhere. The zipper is a minor annoyance, but it's not quite bad enough to force me to redesign it with a velcro cover (that would also have drawbacks). When it rained, my rain parka covered over the fanny pack, keeping everything perfectly dry but still accessible.

When we were returning home from Nepal, the Security Guards at Kathmandu Airport were very polite, but they confiscated a dozen AA-cell alkaline batteries from one of us. We later asked at several places, "Where does it say you should not bring flashlight batteries



## What's All This Battery-Powered Stuff, Anyway?

on planes?” (SMWISICDI)<sup>6</sup> We never did get a good answer. But recently a friend who travels a lot told me that in Korea and several other Asian airports, the Security people do confiscate flashlight batteries in your hand-baggage for fear of saboteurs using them to ignite explosives. So be sure to keep your flashlight batteries in your checked baggage—that is OK.

Of course, lead-acid batteries can be pretty dangerous, and they're normally forbidden on planes. But I found one company that sells lead-acid batteries for electric wheelchairs that are approved for airline travel.<sup>7</sup> So if you need larger batteries than ordinary Nicads or small sealed lead-acid batteries, that may be a good resource.

One other thing about your camcorder or portable computer—when you go to the airport, the security people like you to be able to turn it on and demonstrate that it really does work (not just a dummy packed full of dynamite). So make sure your batteries are charged up.

This is especially important if you are travelling outside the United States, because security in Europe and Asia is a lot more rigorous. Of course, this is contradictory to the premise that the airport security doesn't want you to carry any batteries. Ask your travel agent what to

do!

Now, I have been talking mostly about charging problems for a camcorder. But in reality, if you have a little portable computer, or radio, or transceiver, and you travel out of the United States or far away from line power, you will probably have similar problems. Maybe these ideas will be useful. Stay tuned for more!

## REFERENCES

1. John Christensen suggests trying a solar panel, about \$60 for 14 V at 200 mA. I am ordering one from Solar Electric Inc., 1450 Harbor Island Dr., Suite 204A, San Diego, CA 92101; (800) 842-5678.
2. Crank-Dynamo AM-FM radio, about \$34. REI CO-OP, 20640 Homestead Rd. at Sunnyvale-Saratoga Rd., Cupertino CA 95025; (408) 446-1991.
3. The Electronics Flea Market is held on the second Saturday of each month from April to October, 6 AM to Noon, at Foothill College, Los Altos, CA at the Moody Rd. exit off I-280. Free entry for shoppers.
4. The Pittman Co., Harleysville, Pa. 19438-0003. Model “GM9413-3”, 12 V, 175 in-oz., 65.5:1 gear ratio. About \$28 in quantities of 1-9. The same GM9413 gear motor with 38:1 gear ratio is preferable, because it can put out twice as much power without exceeding the gear box's maximum torque rating. Call

**What's All This Battery-Powered Stuff, Anyhow?**

(215) 256-6601.

5. Raincoat for rain and spray protection, Models E190, E191, E192 (depending on the size of your camera), about \$150; Ewa-Marine c/o Pioneer Marketing & Research Inc., 216 Haddon Ave., Suite 522, Westmont, NJ 08108; (800) 257-7742. Also, waterproof plastic-bag housing for down to a 30-ft. depth, Model E176 or similar, \$350. (These are actually manufactured by Goedecke & Co., Kirchheim, Germany.)

6. "Show Me Where It Says I Can't Do It,"

Pease Porridge, Electronic Design, May 9, 1991.

7. Mobilelectrics, 4311 Woodgate Lane, Louisville, KY 40220; (800) 876-6846. Deep-cycle, sealed-lead-acid batteries, \$69.95 plus UPS, "Airline Approved." ■

*RAP/Robert A. Pease/Engineer*

*to view this article online,  [click here](#)*

[RETURN TO THE TABLE OF CONTENTS]



# What's All This Battery-Charging Stuff, Anyhow

*Originally published Feb. 5, 2001*

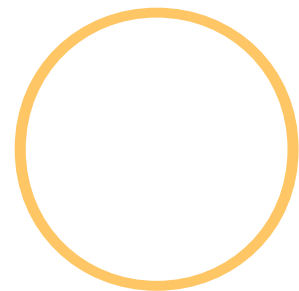

On October 4, at noon, I sat down at my breakfast table, and plugged in my soldering iron. I was going to build the circuit shown in Figure 1. I had one hour to put it together, which was enough time, and then I was going to drive down to the airport to fly to Kathmandu.

As the soldering iron was warming up, I looked for the collection of parts that I needed for this circuit and had shoved into an envelope. Rats! Where were they? I knew I had left the parts in a safe place. I searched in every reasonable spot, every pocket of my briefcase, and all around my house. After 10 minutes, I gave up and unplugged the sol-

## What's All This Battery-Charging Stuff, Anyway?

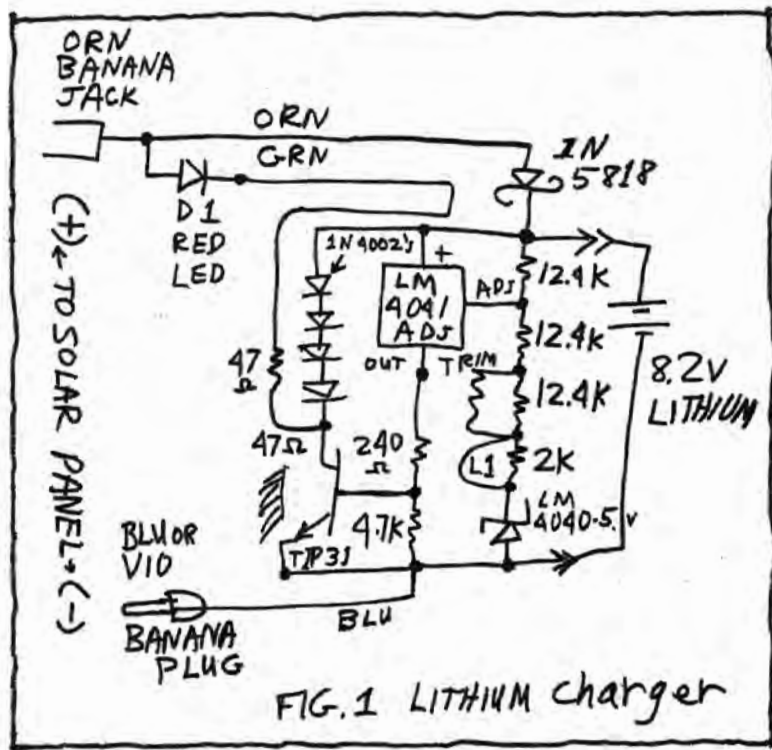

dering iron. (Later, 10 miles up the trail above Namche, I found the parts in an envelope in my trousers' left front pocket, which, of course, was a "safe place.")

Fortunately, the circuit that I was going to build was just a spare, a back-up, and we never needed it. So, it wasn't a big deal that it didn't get built.

About eight years ago, I explained in "What's All This Battery-Powered Stuff, Anyway?" that I used a gear-motor with a hand crank, at about 40 RPM, to charge up the batteries for my new Sony camcorder when I was off backpacking or trekking. That was better than nothing. But the gear-motor's max-

imum output—barely 2 W!—was limited NOT by the motor, nor by the strength of your arm, but by the gears' maximum allowed torque, which was NOT a lot. So a couple of years later, I bought a small solar panel that could put out much more charge on a typical sunny day. Next, I bought a bigger, yet lighter panel. Then when I was in Kathmandu, I discovered that one of my panels had apparently quit (really, it hadn't), so I bought another panel from Lotus Energy (see the table).

Because my camcorder batteries have been mostly NiCads, I used a simple circuit and just let the solar panel's photocurrents flow into my batteries. The circuit shown in Figure 2 is merely a simple scheme with a Schottky rectifier to connect the solar panel's output to the battery, plus a detector to show if the battery isn't connected. If the battery is below 8 or 9 V, the LED will NOT turn ON, and that's GOOD. That means the battery is getting charged,

SOME AVAILABLE SOLAR PANELS

|    | Weight (lb.) | L × W (in.) | Output        | Price | Supplier           |
|----|--------------|-------------|---------------|-------|--------------------|
| #1 | 1.5          | 12 × 13     | 0.30 A × 20 V | \$140 | Backwoods Electric |
| #2 | 1.0          | 10 × 20     | 0.40 A × 20 V | \$110 | West Marine        |
| #3 | 1.4          | 10 × 16     | 0.40 A × 14 V | \$105 | Lotus Energy       |
| #4 | 1.0          | 10 × 20     | 0.40 A × 20 V | \$100 | West Marine        |

Of course, #3 can't charge two 8-V batteries in series, but OK.

## What's All This Battery-Charging Stuff, Anyway?

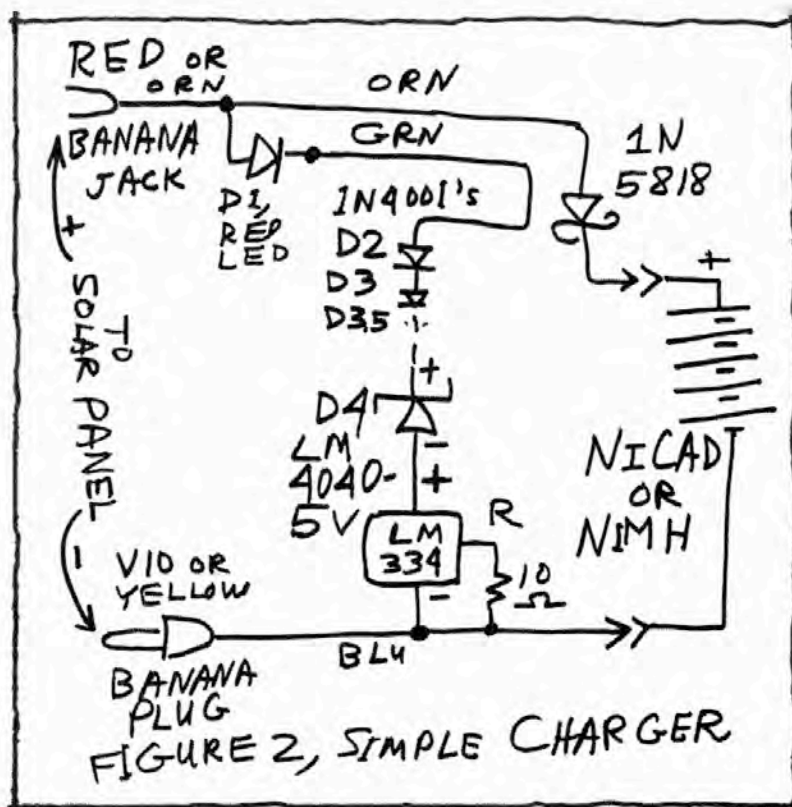

and holding the voltage low. But if the voltage is above 10 V, the LED will turn on, indicating that the battery is NOT getting charged. This is a bad thing, so the LED signifies bad news. It's time to re-adjust the rubber bands! I mount the LED right near the banana plugs, which I keep outside of my pack's back pocket, while the battery rides inside the pocket. The solar panel is lashed on top of my pack.

The number of 1N4002s in series at D2, D2.5, D3, D3.5 should be perhaps two or three, but maybe more, depending on your actual battery. I recently found that one of my batteries has six

NiCad cells in it, not the usual five, so I had to use a couple of extra diodes in series, or the LED wouldn't have gone out!

Many SONY and RCA camcorders have a simple flat interface to the battery, where it was easy for me to set up a couple of small blunt bolts or pins, to be pressed against the recessed terminals of the battery. The connector should be arranged and keyed in such a way that it cannot be applied BACKWARDS to the battery. The sketch of how I did mine is shown in Figure 3.

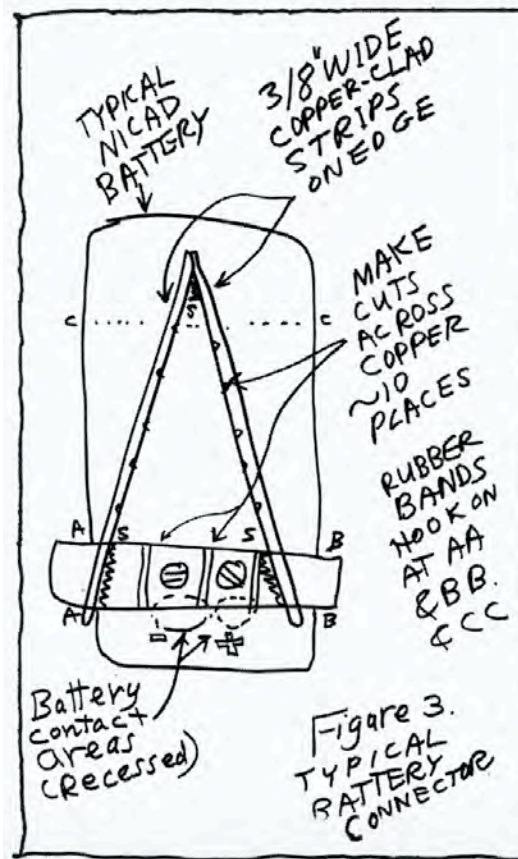

I used tin snips to cut copper-clad 1/16-in. epoxy material into thin strips, such as 3/8-in. wide. And I used a hack-saw blade to saw a dozen gaps in the copper. I soldered three of these thin strips (at the places marked with

## What's All This Battery-Charging Stuff, Anyhow?

S) to make a triangular frame, which is easy to strap to the battery with a few rubber bands. I used the isolated foil areas to solder up circuit nodes, such as the LM334 and various diodes.

How do I know how much charge to put into a NiCad battery? I have several two-hour NiCads (2000 mA-H). If the battery gets low, and the camcorder shuts off because it's low, then I can put in well over 1 A-H, or  $0.3 \text{ A} \times 3$  or 4 hr., before I need to taper off. Usually, if I'm charging up one battery, I'm using another one to record with, so rather than worry about EXACTLY how full it is, I just swap batteries and fill up the one I was using.

What if I'm going to leave camp and leave my battery charging in the sun? I will usually put the solar panel in a sunny place, and lay it out at an angle so that the solar radiation will get more oblique as the day goes on, and the rate of charge will taper off. I might just put the panel FLAT on the ground. At noon, the sun will come booming in, but in the afternoon, the panel's output will drop a lot. If the panel's output falls to 0.2 A, a 2-A-H battery can take that much current in for a long time with no harm (C/10 rate). My panels can put out about 0.4 A, which is NOT a horrible amount.

Many modern camcorders have a gauge to tell you if the battery is nearly full, or what. (Some batteries come with a "fuel gauge," and most of those are rather optimistic; after one-half hour of charge, they say that the battery is full, which is obviously malarkey!) Of course, the correct way to terminate charging on NiCads is to detect when the battery has a rapid rate of rise in temperature. But I have never had to do that when hiking. For a fixed installation, I would probably set one up.

One of my trekking friends had NiMH batteries for his newer camcorder. I checked it out, and NiMHs like to get charged the same way as NiCads. Just push in the amperes until the battery is nearly full, but be sure to taper off to C/10 when it gets full. I told him to do exactly what I was doing, and he made similar adapters.

But a couple of my trekking friends had new camcorders with lithium batteries. I knew that you have to be very careful with them, because overcharging a lithium battery can lead to RAPID DISASSEMBLY. Most of you guys know what that is...or you can figure it out.

So, it's important to have a reliable regulator that will charge your lithium battery up to 8.200 V (or 8.400 V) and

## What's All This Battery-Charging Stuff, Anyway?

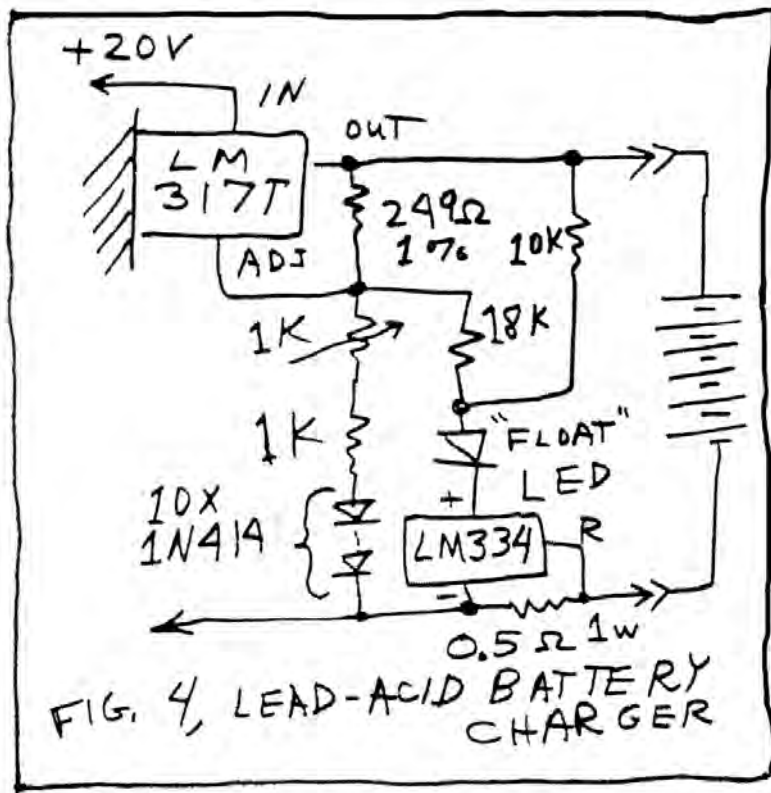

no higher.

NSC makes two nice little ICs that can do that, the LM3420 and LM3620. These are nice, accurate series regulators, but they're NOT easy to turn into shunt regulators. I want a shunt regulator, and here's why:

A solar panel is a current source. It puts out an approximately constant current into any load that you connect to it—even a short circuit. Plus, even if you leave its output open-circuited, it isn't unhappy. When you think about it, it's fundamentally different from any ordinary voltage source. (For further notes on 50 good current sources, see the

Web seminar I gave on Dec. 6, 2000, in the archives at [www.netseminar.com](http://www.netseminar.com).)

When I put the output of a 20-V solar panel into an 8-V battery, some power is wasted, but that's not a big deal. The battery and the solar panel are both happy about this situation.

If I want to get all of the energy possible from that solar panel, I feed that current into a series stack of two 8-V batteries. To do that, you need current-mode charging, and you need shunt regulators, not series regulators. Then if my batteries are low and I'm just coming into a period of sunshine after a long spell of clouds, I can simply stack two of them in series and shove the current through BOTH of them. Best of all, these batteries, with their shunt regulators, are mix-and-match, so I can stack any two in series. I can charge up one of my NiCads in series with an 8.2-V lithium, or a NiMH in series with an 8.4-V lithium, and the solar panel just kicks the charge into both. If one of the lithiums gets full, the charge is shunted through the power transistor and it keeps flowing through the other battery, so charging continues. This wouldn't be possible with a series regulator. Because we had about 12 batteries, four solar panels, and about 10 regulator modules on our trek, we weren't only

## What's All This Battery-Charging Stuff, Anyway?

self-sufficient, but we were inter-operable. As a result, the loss of any one regulator or any one panel wouldn't stop us. It would barely slow us down.

Could I use a switching regulator to convert 20 V at 300 mA into 8 V at 700 mA? YES, in theory I could. But I don't usually need quite that much efficiency. I built one, once, and it did work, but it wasn't a winner even though it weighed only 1 ounce. Usually, it's just fine to stack the two batteries in series. Simplicity is a great virtue—even though I have to carry around two batteries that tend to get a bit heavy!

### Connectors

---

We have all seen power systems using fancy connectors. When they get banged up, they're impossible to repair. Our Head Porter had a solar panel that he carried on his back every day, thus making five of us solar guys on this trek. His panel fed into the batteries that he used to run our fluorescent lantern. But his connectors were RCA phono plugs, and when they got abused, they were not only unreplaceable (Namche Bazaar has a few radio repair shops, but had ZERO pieces of RCA plugs/jacks that could be bought or scavenged for repairs), but they were nonrepairable.

For nine years, I have used as my standard convention, that the + wire from the solar panel has an orange (or red) banana plug, which mates with an orange (or red) banana jack, and an orange (or red) wire going to the battery. The - side is reversed in gender: a violet (or blue or yellow) banana jack from the solar panel, and a violet plug tied to the battery. This makes it easy to connect two batteries in series. (Yes, I know it looks funny when the two batteries are connected in series by plugging a yellow plug into an orange jack, but it's perfectly OK, and nothing can go wrong.)

Further, there's hardly ANYTHING more repairable than a banana plug (which works great with no solder) or a banana jack (wrap the wire around the tab and crimp it or put on a minigator clip). We had zero trouble on the trek with our wires or connectors. (When the porter's RCA plugs failed, we managed to coyote them up—lashed them in parallel—and the lamp kept working every night.)

Now let's look at the circuit of Figure 1, the critical one for Lithium batteries. The LM4041-ADJ is basically OFF if the battery voltage is below 8.2 V. The circuit draws only 140  $\mu$ A. This means that all of the current from the solar panel



## What's All This Battery-Charging Stuff, Anyhow?

flows into the battery. When the voltage gets up to 8.2 V, the LM4041 sees 1.24 V at its ADJUST pin, so it turns on, and it turns on the big NPN to shunt off all current necessary to hold the battery voltage at 8.2 V. When this happens, there's enough current to turn on the red LED. So, if the battery is fully charged, the red LED turns ON and tells you this. Or, if the battery isn't connected, the red LED will also turn on. You may have to check your connections to tell which is happening. Still, it's a good two-mode indicator. It only wastes 10 mA in the LED when the battery is NOT getting charged. But the big NPN has to carry as much as 400 mA, and it can get hot, so be sure to provide an adequate heat fin.

This circuit is set up to be trimmed to 8.2 V, but if you disconnect the link L1, the voltage goes to 8.40 V. Which one should YOU trim for?

Connect a couple of small wires to your lithium battery's terminals, and monitor the voltage with a DVM as you charge it. If it stops at 8.2 V, that's what you need. One of our guys had an 8.2-V battery in his Canon Elura. The other guy had an 8.4-V lithium in his Sony. Most people would set up the regulator for just their battery. The circuit of Figure 1 was going to be trimmed

for BOTH voltages, with a link to snip to get the higher voltage. How do we know for sure? We brought two DVMs to Kathmandu, and then we brought the lighter one along on the trek. We just trimmed the basic circuit of Figure 1 to 8.2 V by adding various high-value resistors across the 12.4 k in order to get the voltage to  $8.2 \text{ V} \pm 0.25\%$ . Then if we needed 8.4 (see the table), we would just undo the link. (Because we had low-temperature solder from Radio Shack, we could reconnect any wires using a match for heat.)

The 8.2-V battery for the Elura clipped onto its regulator by rubber-bands. The 8.4-V battery for the Sony had two small sockets set into the battery, and a couple of MINI banana plugs matched those sockets perfectly. I used to be nervous about lithium batteries, but now I'm perfectly comfortable with them. When you charge the battery with this circuit, it pulls the battery right up to 8.2 V, and then it keeps it at a full state. The LED tells you that it's full. Even if something FALLS OFF, the battery cannot be over-voltaged or overcharged.

What's the right way to charge lead-acids? (Fig. 4). That circuit can put out 14.4 V to bring a "12-V battery" up quickly. But after it gets up there, hysteresis is added through the 18 k, to

## What's All This Battery-Charging Stuff, Anyhow?

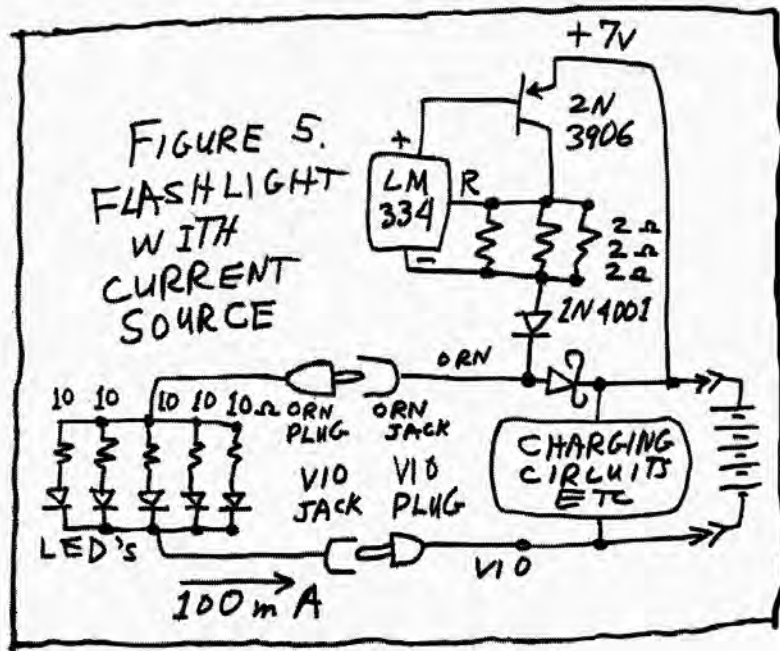

bring the voltage down to a float voltage of 13.4 V. This circuit does have temperature compensation, because on a hiking trip or trek, you could easily have a working temperature range between +120°F and 0°F. You wouldn't want to over-charge the battery when hot, and you wouldn't want to under-charge it when cold, which is what would happen if you charged it to a fixed 13.4 V at all temperatures. (The other types of batteries don't need temperature compensation.)

So trim that pot to get 13.4-V DC at no load at 25°C, and (13.4 V ± 22 mV/degree) at temperatures away from +25°. In this circuit, the LM334 is NOT used as a current-source, but as a low-volt-

age comparator. This circuit is a series regulator because you won't be stacking two of these!

(The town of Namche Bazaar has good reliable 220-V AC power. But some of the innkeepers have learned to charge tourists and trekkers high prices—as high as \$4 to \$7 for charging one battery. When they get you over a barrel, they really know how to get you! Also, above Namche, there isn't a lot of reliable electricity available. Therefore, it would be very hard and/or expensive to bring a group of batteries and only record a LITTLE. By bringing my own charging equipment, I had no trouble recording 23 hours of video in 35 days on the trail. Of course, it took up a lot of my Christmas vacation to get all of the video listed and ready to edit down to a few one-hour tapes!)

Several people along the trek asked why we were carrying these solar panels, and we explained. Some of them said, "Hey, that sounds like a really good idea. I left my camcorder at home because I couldn't figure out how to charge its batteries. Let me know when you can tell me how to do it!" Well, that's what this column is about.

The flashlight that I hooked up to a battery can be seen in Figure 5. The LM334 and 2N3906 form a 100-mA

## What's All This Battery-Charging Stuff, Anyhow?

current source. When you unplug the solar panel and plug in this flashlight, it's a pretty good little light. Normally, you wouldn't want any discharge path if you shorted the orange and violet terminals together. But because this is just a regulated 100 mA, the battery won't be abused. The components of the little current regulator are easy to mount inside of one of the A-frame members. You might switch out one or two of those 2- $\Omega$  resistors to adjust the brightness.

I arranged the LEDs (Digikey Part CMD333UWC-ND, about \$3) in a fan array, to make it easy for reading. You can point them anywhere you want, though. The current source shown here isn't as efficient in voltage as the one I showed back in the September 5 issue. I did that on purpose, because I wanted this circuit to quit drawing current if the

voltage supply gets down to 6 V to protect the battery. This circuit does have the advantage that it connects to the load and the battery with just two wires, rather than four. Therefore, the wiring is much easier and safer. Now my best flashlight is easy to recharge! A solar-powered night-light!

These are some of the circuits and procedures, the tricks, and the connectors that kept us running with plenty of charge for over a month. Did our batteries ever get low? Yeah, after three days of gray weather. That's why we like to keep our batteries charged up pretty full, almost all the time! ■

*RAP/Robert A. Pease/Engineer*

*to view this article online,  [click here](#)*

[RETURN TO THE TABLE OF CONTENTS]



# What's all this Soakage Stuff, Anyhow

*Originally published May 13 1998*

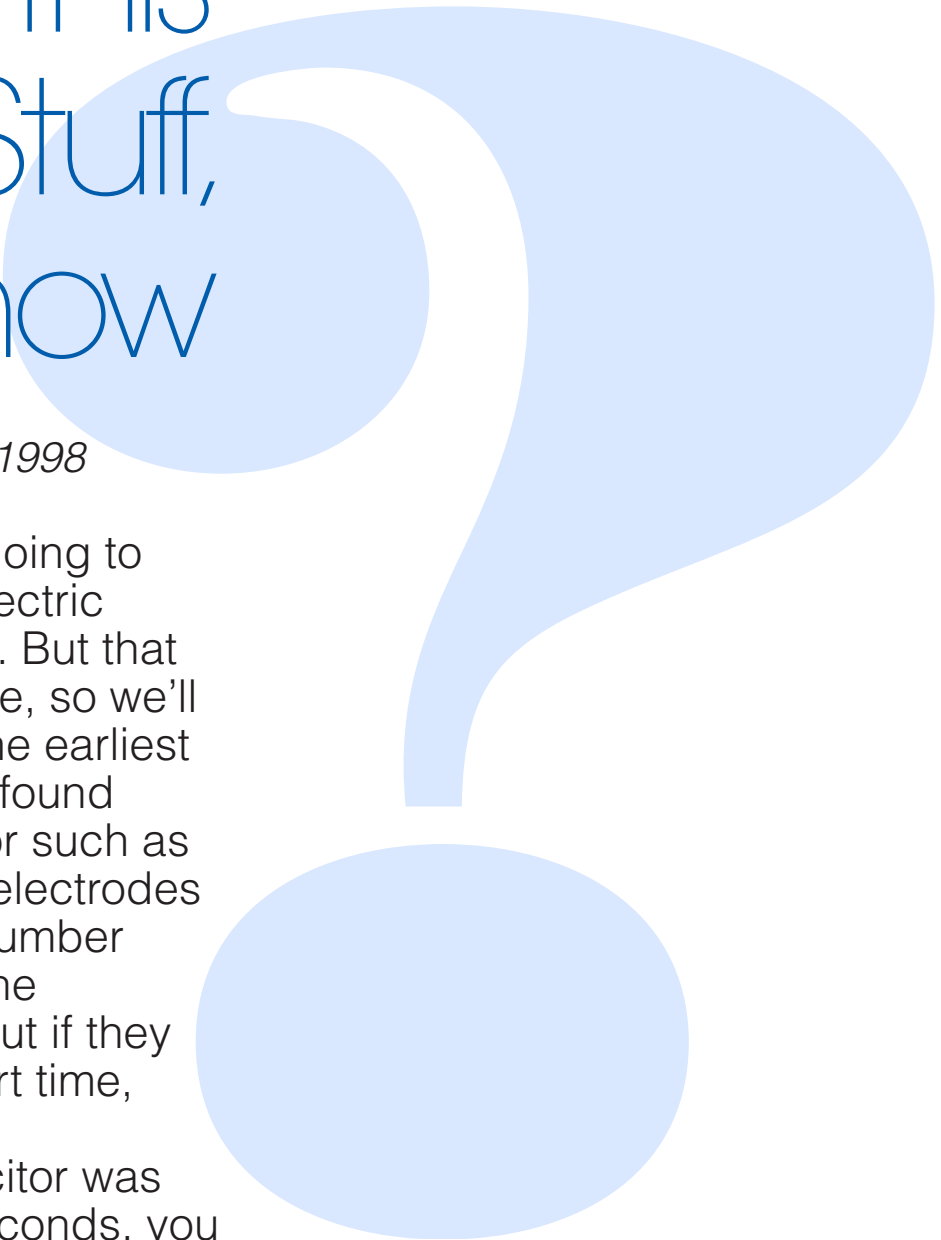
Of course, this column is going to be talking about the Dielectric Absorption of capacitors. But that is much too long a phrase, so we'll call it soakage, or DA. The earliest manifestation of DA was found when old experimenters had a capacitor such as a Leyden jar (a glass jar with metal foil electrodes inside and out) charged up to a large number of volts. They knew if they shorted out the capacitor, the charge would go away. But if they shorted out the capacitor for only a short time, the voltage would recover.

For example, if a 2000-V, 0.1 $\mu$ F capacitor was discharged through 220 k for just 20 seconds, you

## What's All This Soakage Stuff, Anyhow?

would expect it to be well discharged. So, if you came back a few minutes later and got a really big jolt from that capacitor, you would be surprised. This was well known as early as the 1700s, and was documented 100 years ago as “residual charge,” in my 1894 Encyclopedia Britannica.

In the early 1900s, the theory of dielectrics provided a fairly good explanation of how the molecules were slowly polarized to store charge—and how they were slow to let loose of their polarization when the original voltage was removed. All capacitors have some DA, but there are many octaves of relative goodness (or badness). When you have filled up the capacitor with charge, after you try to short that charge out, the soakage charge just keeps coming out of the capacitor. (Of course, if you thought you had charged a capacitor up to a new value, it would take a while before it stopped needing extra charge. Soakage is a fairly linear effect: It's just as hard to charge a capacitor up as it is to charge it down.)

The original definitions of DA were only spelled out in terms of hours. If you charge up a capacitor for an hour, then discharge it for a minute, and come back an hour later, what is the voltage? The oil-filled capacitor used in

the high-voltage power supplies of old radios, was pretty bad—as much as a 20% voltage error. That's a lot of hidden charge. But many good capacitor materials such as polystyrene were 100 times better than that. So, you didn't have to accept 20% errors. A darned good thing!

Where is a practical example of where soakage is important? Well, if you turn your color TV off and open up the back, what's the first thing you have to do before you start working on it? Put a grounding strap on a screwdriver and reach under the rubber shroud on the HV plug to discharge the CRT. OK, now that capacitance has been discharged, how much voltage will “soak” back into the “capacitance” of the picture tube if you let it sit for about 10 minutes? Enough to make a visible arc when you discharge it the SECOND time...now that's what I call dielectric absorption. So, you don't want to fool around with a real high-voltage capacitor, if it has only been discharged once.

Still, if you know what happens every time you charge up a capacitor for an hour, how can you tell what will happen when you charge it up for one second, or a millisecond, or 10 microseconds? This isn't obvious.

The model for a capacitor with soak-

## What's All This Soakage Stuff, Anyhow?

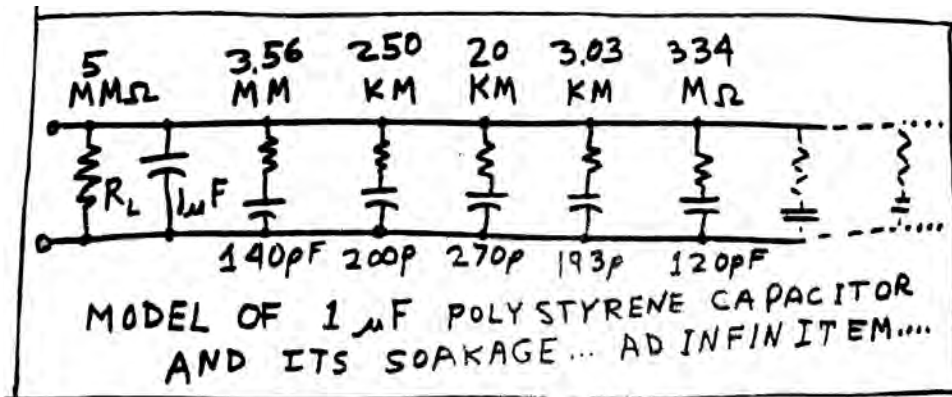

age is a big capacitor, in parallel with several small capacitors in series with various large resistors (see the figure). If we put a dc voltage on the capacitor for 0.1 second, some of those smaller capacitors will be charged up, but some of the bigger ones will take more time.

Back in the 1960s, I fooled around with some rather good capacitors, and a few mediocre ones. At Philbrick, I made some very good integrators. I started with teflon capacitors, and FET switches to reset the integrator after it had been integrating for a while. We had several different reset circuits and sample-and-hold circuits.

The fun circuit for resetting your integrator was an old circuit from the early 1950s, that used vacuum tubes and a neon lamp. When you wanted to reset the integrator, a pentode was turned on, and a small RF oscillator started up. The output of the oscillator was fed to a wire wrapped around an NE-2 neon lamp.

Presumably the neon lamp was induced into conductance, went to low impedance, and reset the integrator. I have never built this up, but maybe I'll do it. I wonder if it works well at all. But, I suspect, not.

When the integrator was reset, the main capacitance was shorted out. Some of the faster RC networks would be discharged, but the slower ones would cause significant errors. So I engineered some compensator networks to compensate out, cancel that charge.

I have a pretty good write-up on my web pages. There, I wrote that nobody ever talks about soakage or dielectric absorption in any detail. Recently I received letters and e-mails from readers, one of which pointed out that *The Art of Electronics*, by Horowitz and Hill, has a neat little explanation of DA.

I tried looking it up in that book (the original 1980 edition), and I nearly went blind looking for it. Nothing in there. Finally I got suspicious and went to our library, to look in the second edition (1989). OK, there is some mention there, but they don't say much quantitative about soakage. Then other people wrote to me, pointing out some of the seminal work in the field, by Paul C.

## What's All This Soakage Stuff, Anyhow?

Dow, Jr., in 1958, and Robert Guyton and Joe McKay in 1968.

Dow, in the IRE Transactions on Electronic Computers (analog computers, in those days, of course), March 1958, pp. 17-22, measured the soakage of the best capacitors of the day—polystyrene. His data resulted from measuring the current flowing out of a capacitor after it had been charged for a long time, and discharged for a short time. His model of the soakage showed that a basic 1- $\mu$ F polystyrene capacitor might appear to have a series RC network across it, such as 140 pF in series with 3.5 Mega Megohms (MM $\ddagger$ ), a 200 pF in series with 250 kiloMegohms (kM), a 270 pF in series with 20 kM, a 190 pF in series with 3 kM, and another of 120 pF in series with 330 M $\ddagger$ . (Figure 4 at my web site is quite comparable, but the losses are worse because it's a model for a mylar capacitor.) Dow indicated how much trouble these RC networks would cause for various analog-computer and integrator circuits, such as unwanted phase shifts and errors when making an oscillator out of a couple integrators.

But Dow looked at the soakage in time-frames from 1000 seconds to just 0.1 second. Hey, it's a fact that the official definition of dielectric absorption

requires a capacitor to be charged up for 10 minutes, discharged for 1 minute, and then monitored for another 10 minutes. But that doesn't tell you much about how your sample-and-hold circuit will "distort" if you're looking at a small signal just 10 or 1 ms after it was discharged from a large voltage!

So, in my studies, I ran charge and discharge times from 100 seconds down to 100  $\mu$ s. You can look at the characteristics of various different types. I must admit, I did run all of my tests with a TCHARGE:TDISCHARGE of about 10:1. But the results over wide dynamic ranges showed that the accuracy of a sample-and-hold capacitor tends to get better as you go faster.

The other guys—Guyton at Mississippi State University, and McKay at Redstone Arsenal—engineered a compensating network for an integrator, to make it closer to perfection. However, while their integrator did have greatly improved phase and amplitude errors during integration, their compensation circuit wouldn't help in trying to reset the integrator to zero quickly. It only worked by changing the phase shift of the input resistor to compensate for the phase and gain errors in the capacitor. If you wanted to short out the capacitor, to reset the integrator, their paper pro-

## What's All This Soakage Stuff, Anyhow?

vided no help at all.

The circuits in my tech paper show how you can get good, quick settling from capacitors in integrators or sample-and-hold circuits, where you need fast reset action. Where is that web site? It's at <http://www.national.com/rap>. Then, at the bottom of my home page, click on the "good technical stuff." It's one of three papers there. If you can't get on the web, write me a letter, and I'll send you a copy of that paper.

Can you hear the advantage of low-soakage capacitors in your hi-fi amplifier? Lots of experts say "yes"...those golden-ears again. If an amplifier is "capped" by taking all electrolytic capacitors out of the signal path, and replacing them with good film capacitors, it has to sound better. All the experts say it sounds better.

Tom Nousaine (who did ABX testing on speaker cables) says the golden-ears cannot hear a difference, in truly blind tests. I believe him. Of course, that does not mean that there are no differences. Nousaine is careful, after all, not to leave all the controls "flat," because this might let out all sorts of differences in frequency response. He makes sure that the gains of both amplifiers are matched within 0.1 dB at 0.1, 1, and 10 kHz. If one did not do that,

one might hear a difference.

Now, that does NOT mean we can't hear the effects of a tantalum capacitor in a poorly-designed circuit, with improper bias. I'll run some tests on those, soon. But it's well-known that tantalum caps can sound pretty weird if they are ever allowed to get biased the wrong way during part of a cycle. I bet even I can hear that kind of distortion.

I heard a great story about some extreme tests on capacitors. The engineers took a 1- $\mu$ F mylar cap and charged it up to its rated voltage, say 50 V. Then, they heated it to 150 °C, for a while, afterward cooling it down to room temperature, still maintaining 50 V. Next, they shorted out the capacitor and measured the charge. Of course, they got 50  $\mu$ C, or  $Q = C * V$ . That's what you'd expect.

Then, they held the capacitor at 0 V, and heated it back up to 150 °C. The amount of charge that flowed out of the cap, as it was heated, was larger than 50  $\mu$ C! Of course, 150 °C is considerably outside of the normal working range for mylar capacitors, but it did not cause any problems, other than this huge amount of residual charge stored on the molecules of the dielectric!

Recently I read an e-mail from an old friend, who said that one web expert



## What's All This Soakage Stuff, Anyhow?

asserted that speaker cables made with low-soakage materials will sound better than cables made with high-soakage insulation. He claimed that since Pease explained how soakage works, the better cables must sound better. My friend asked me if there would be any audible difference.

I thought about it, and I reached into my wallet. I've been carrying around a photocopy of some facts about different types of speaker cables for many months. I don't think I carried them the 200 mi. around Annapurna, but other than that, I've been carrying them for over a year.

Let's assume we are talking about 10 yd. of cable; anything less than that would be sub-negligible. Some of the simple, low-capacitance ones have 10 to 30 pF/ft. Some of the good, low-impedance ones, which I like (made of 32 pairs of wires), have as much as 300 to 700 pF/ft., or 9000 pF to 21,000 pF/30 ft. Let's talk about those.

If you used a 30-ft. length of cable as the storage capacitor in a sample-and-hold circuit, a teflon cable would look pretty good. And the cheap rubber or plastic-insulated cable might make a rather poor sample-and-hold. A 20,000-pF capacitor made of teflon-insulated wire might have, at 1 or 2 kHz, as much

as 20 pF in series with 8 M.

A cable made with poor plastic might have 50 times worse than this, such as 1000 pF in series with 160 k. Mind you, I have not yet measured lamp cord, as a hold-capacitor in a sample-and-hold, but still, this is a ball-park worst-case kind of soakage. Let's see where this leads us.

If you measure the loss factor and settling tails of a sample-and-hold circuit, due to the resistance, the poor cable might look a LOT different. Now, take this poor, lossy cable out of the sample-and-hold, and connect it to an 8- load. Then, drive it from an audio amplifier with 1 of output impedance. If you put 160 k across 8 , it would definitely make a tiny, but measurable difference in impedance—perhaps 0.005%, or 0.0005 dB. It would be different from a teflon cable, all other things being equal. But not a heck of a lot. And, if you consider that the low-impedance amplifier (1 ) is driving this 160 k in parallel with the 8 , that would sound like a 0.00005-dB warpage of the frequency response. I would not call that audible.

So, I replied to my concerned friend, that the “expert” who thinks that speaker cables will sound “different” or “better” if they are made with low-DA materials, will probably have a very thin

## What's All This Soakage Stuff, Anyhow?

chance of telling any difference.

I told him this relevant esaeP's Fable: Do you know the Celluloid Cat? That is the Celluloid Cat being chased by the Asbestos Dog. Well, that "expert" has about as good of a chance of hearing any difference, as the Celluloid Cat being chased by the Asbestos Dog through the Fires of Hell.

In the week after this analysis, I came across two other cases where the parable of the Celluloid Cat came up, because it was a perfectly applicable case. I figured, three times in a row, that

it was trying to tell me something. So here is that fable. NOTE, to young kids and people who cannot remember back 40 years, photographic film and ping-pong balls used to be made from celluloid, and they were REALLY flammable. These days, they are NOT made of celluloid, and not very flammable. ■

*RAP/Robert A. Pease/Engineer*

*to view this article online,  [click here](#)*

[RETURN TO THE TABLE OF CONTENTS]



# What's All This Future Stuff, Anyhow

*Originally published January 12, 2006*

I was down at an “Arrowfest” in Plano, Texas, a few months ago. We had a little panel session about the future with Bill Klein of Texas Instruments, Arnold Williams from Analog Devices, and myself. Most of the audience agreed with the three of us (and the moderator)—the future will have a lot of analog.

When we see that the power-supply drain of a fast processor at 0.09  $\mu\text{m}$  is largely related to the device leakages—which aren’t very predictable and can’t be modeled easily—hey, that processor is relying on analog characteristics.

Remember the old days, when engineers were struggling to bias up germanium transistors so their bias wouldn’t suffer from thermal runaway? Now, the silicon circuits are on the verge of ther-

## What's All This Future Stuff, Anyhow?

mal runaway.

It will take some good, tough engineering to solve the layout and heating problems. Maybe when they turn off the clocks to some subsystems, that area of the chip will stop selfheating, the temperature will go down, and the leakage will decrease—a kind of thermal un-runaway.

I wonder what Moore's Law has to say about that. Obviously, when the "process" goes down to 0.065  $\mu\text{m}$ , it will get much worse. Now that designers can't keep shrinking things, the digital field is going to look a lot different. What will they sell us next year? Microprocessors that aren't just fast battery dischargers?

## FUTURE POWER

---

People are still bringing up the old saying that "Fuel cells are the power source of the future—and always will be." Down here in Silicon Valley, the Transit Authority operates a couple of busses running on fuel cells. This is an ideal area, because it's so flat with very few hills. (They'd never cut it in San Francisco.) From what I hear, the fuel cells have a very finite life and will need to be replaced every few months. And they're expensive! I'm waiting to hear how those busses work out.

Engineers, scientists, and chemists have been trying for many years to reduce the price of fuel cells by an order of magnitude or two. Great! NASA is very happy to pay for such exotic energy sources. Now the fuel-cell makers only have to improve the cells by three or four more orders of magnitude before they fit into future cars.

Are high-efficiency solar panels headed for a big future? I've seen studies that say inexpensive (not-so-high efficiency) solar arrays are the right way to make cost-effective energy. It's fine by me, if the cost of a watt keeps going down. Mr. Ovshinsky of Energy Conversion Devices (ECD) has been saying that for years, and people are starting to follow him.

Furthermore, people are beginning to see that nuclear power plants have a future. It's better than pretending we can buy cheap oil forever. Besides, nuclear power has a much more reliable availability factor than solar power or wind power. All we have to do is get the politicians to agree to hide the nuclear spoils where they won't contaminate us and poison us all.

And maybe this time, we can make sure the shale-oil conversion experts get going and keep going. The U.S. has enough oil-shale to last us many de-

## What's All This Future Stuff, Anyway?

cedes into the future for a large fraction of our energy needs. We only have to prove that we can rely on it at plausible, reasonable price— chop the support for that when the oil shock decreases.

So while I'm not very good at predicting the future, lots of other people are predicting good things! I just hope I'll

be hanging around for many more years to smile at them when they get here!

Nuclear-powered op amps, anyone? ■

*RAP/Robert A. Pease/Engineer*

*to view this article online,  [click here](#)*

[RETURN TO THE TABLE OF CONTENTS]



# (Part 1) What's All This Ripple Rejection Stuff, Anyhow

*Originally published February 4, 2002*

Recently, I helped a guy who needed low output ripple on a power supply. His 1000-V output required low, submillivolt ripple. I designed a couple of circuits for him. Details soon. To make sure that I wasn't missing any tricks, I looked up a voltage regulator, the Philbrick 5910, designed by my old colleague Bruce Seddon about 42 years ago. It was optimized to provide  $\pm 300$  V dc at 100 mA (see the figure), or 300 mA in a larger R-300 power supply when additional output tubes are paralleled.

Anybody can design an operational amplifier (op amp) with a gain of 100,000 or 1,000,000 at dc. But this one needed to swing its output 80 V dc plus 15 V p-p at 120 Hz, with a summing-point

## What's All This Ripple Rejection Stuff, Anyhow?

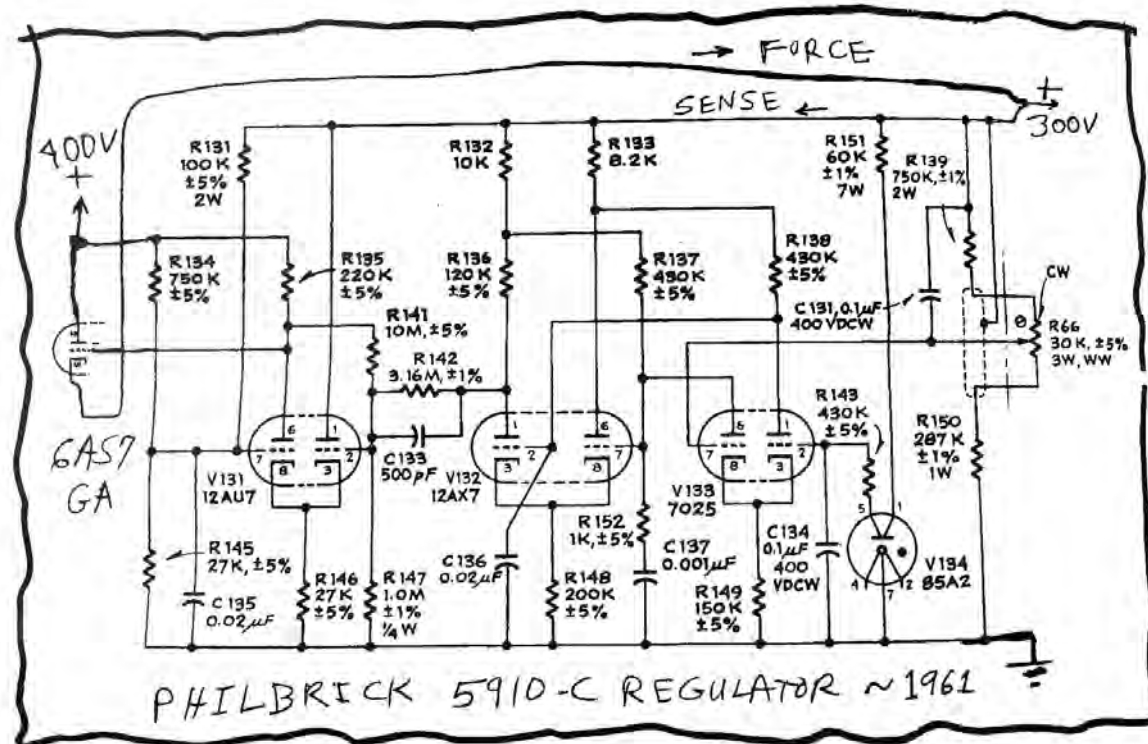

high-line. Also, it has submillivolt gain error, for line, load, or ripple.

There are good bypass capacitors, such as at C131 and C134, to filter and bypass the noises for frequencies above 4 Hz. That helps keep the output's noise below 250  $\mu\text{V}$  rms. This amplifier was also optimized for fast bandwidth. The output bypass capacitors (not shown) were 150  $\mu\text{F}$  at 525 VDCW, specified

error of less than 150  $\mu\text{V}$  ac rms. That's 100 dB of gain at around 120 Hz! Forty years ago, most regulator amplifiers had two-stage amplifiers. But this one used three dual triodes for each supply, + and - 300 V. Two honest stages of 12AX7 provide a lot of gain ( $\mu = 100$ ), and the 12AU7 ( $\mu = 20$ ) gives a good healthy drive to the grid of the output tube (6AS7GA).

Additionally, the positive feedback of R132, R133, and R141 provides much more gain—even at 120 Hz, and at dc. Although the output pass tube (6AS7GA) has a  $\mu$  of only 2, this amp can easily drive the grid to any necessary voltage, whether no-load or full-load, low-line or

with good low RS.

The 5910 dual regulator amplifier was built in a little boxy subassembly. The tubes stuck up above the box, with the passive components mounted on turret terminals along the insides of the box.

I bought a 30-year-old R-300 that was still in very good shape. I used a Variac to turn up the line voltage very slowly to “form up” the electrolytics. It would be harmful to apply full line power right away. I fired it up and it regulated nicely.

After I did a general check-out, it was time to do noise testing. I used a series stack of three 25-W light bulbs to draw ~190 mA of load. The ripple voltage on the main (“upstream”) filter capacitors

## What's All This Ripple Rejection Stuff, Anyhow?

rose to 9 V p-p. The output ripple-plus-noise increased from 100  $\mu\text{V}$  rms to perhaps 120  $\mu\text{V}$ —truly negligible, barely 3 ppm (p-p) of the dc output, even at full load. The ripple was barely 40  $\mu\text{V}$  p-p. Not bad! The load regulation was sub-millivolt, and the line regulation was very good too.

So it's encouraging that 40 years ago, a high-gain three-stage op amp could provide excellent ripple rejection, and that old machine still runs well today. Soon, I'll show how to get low ripple voltage by adding an add-on circuit to an existing high-voltage supply. Perhaps using a fast FET op amp running on  $\pm 6$  V.

I'm looking forward to using that old R-300 to run a whole bunch of tests on various old vacuum-tube operational amplifiers. I've been waiting to do that for years! We rarely use vacuum tubes these days, but here's a good example of how tubes could do some very good work. I'll have more comments on the old art of designing with tubes, and the early days of operational amplifiers, 40 or more years ago. ■

*RAP/Robert A. Pease/Engineer*

*to view this article online,  [click here](#)*

[RETURN TO THE TABLE OF CONTENTS]





# (Part 2) What's All This Ripple Rejection Stuff, Anyhow

*Originally published December 9, 2002*

Okay, I wish I could tell you guys that I have improved the old R-300's noise down to 1  $\mu\text{V}$  rms, on top of its 300-V dc output. I tried. I applied both the Type A servo amplifier from last month (electronic design, Nov. 11, p. 84) and the new Sallen-Key filter, Type B, shown in the figure. It's battery powered, and the LMV751 runs well on three AA cells. (If you want long and cheap battery life, use C or D cells instead.) I also used the level-shifter, and the pre-amp and NoiseMaker shown at [www.national.com/rap/ripplerej.html](http://www.national.com/rap/ripplerej.html).

Actually, I was able to work the noise down from 75 to about 9  $\mu\text{V}$  rms, using each of the Type

## Part 2: What's All This Ripple Rejection Stuff, Anyhow?

A and B circuits. I tried to get it lower, but the spatial orientation of the magnetic flux in the neighborhood would have made it very hard to get anything below  $9\ \mu\text{V}$ . I'll never say never, but it's not easy. Magnetic fields are nasty and hard to shield or screen out. Layout is critical and not easy. Maybe I'll just put longer wires on the pre-amps and move them far from the R-300, the transformers of all the power supplies, and the voltmeter. Might work!

Further: Look at the careful filter structure of the schematic diagram of the figure, Type B. There should not be much  $1/f$  noise. But I had plenty of jitter, wobble, and  $1/f$  noise—much more than I expected. There was maybe 10 to 20  $\mu\text{V}$  of jitter. I considered the layout and the characteristics of the mylar capacitors (400-V capacitors running on less than 150 V dc), yet I couldn't find much of a clue as to what was causing the noise.

Then I thought about the resistors. Can an AB 1/2-W, 5.1-M $\pm$  resistor running at 150 V generate enough  $1/f$  noise—current noise—to make a poor reading? Maybe so. I will study this later, just not this week. There are some trick tests that I'll want to run.... Hey, I never looked this closely before!

I did get some good data on the ac

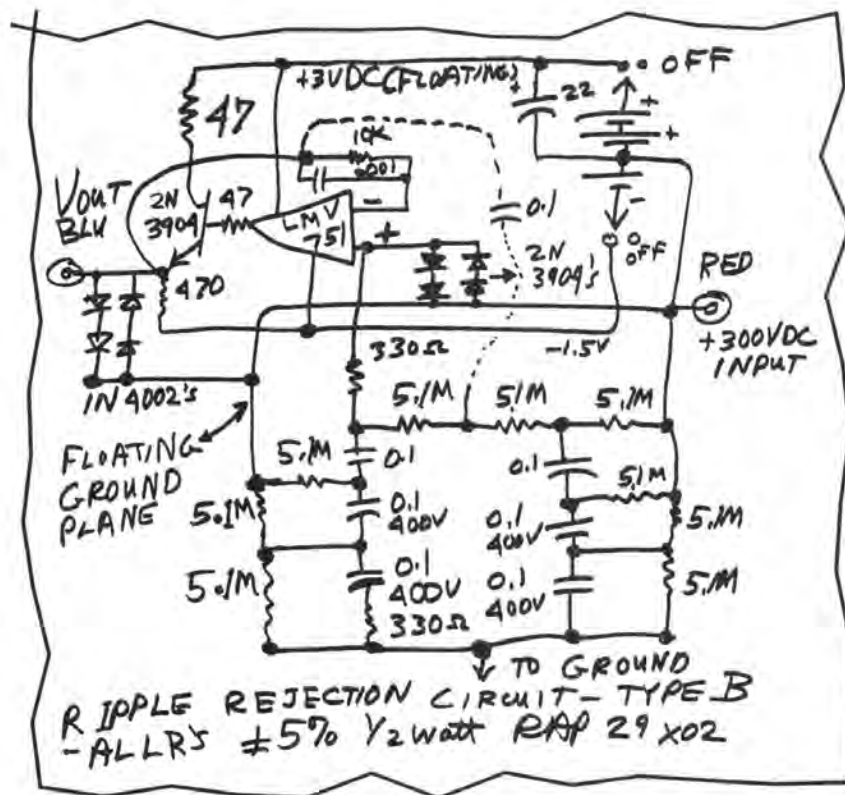

ripple-rejection, using my NoiseMaker (schematic is on my Web site) to try to cut the ripple of an 85-mV p-p (26-mV rms) noise at a 26-kHz nominal switching frequency, with lots of harmonics at 52 and 78 kHz. Although the Type A circuit improved the 26 mV to 0.88 mV, Type B did a bit better at 0.83 mV. But that was NOT unexpected. So it's not too hard to get a 30-dB noise improvement by employing a cheap, low-noise op amp, such as LMV751.

Both schemes worked pretty well. But Type A didn't like to tolerate a lot of capacitive load from the op-amp's output to ground—that is, the capacitance

## Part 2: What's All This Ripple Rejection Stuff, Anyhow?

from the power-supply low terminal to ground. It was able to drive the R-300's capacitance. But adding a coax cable over to the voltmeter made it grouchy at 4 MHz. So I just had to bring the voltmeter (HP3400A) over by the amplifier.

Yet Type B would surely be grouchy if there was a lot of capacitance from  $+V_{OUT}$  to ground. So any fast, nimble, low-noise amplifier may get grouchy about capacitive loads. In some cases, a series R-C damper can help. There are no easy answers. If I got a "hotter" op amp with a lot more than 4 MHz of GBW product, that would certainly help;

and some 26- to 52-kHz noise can be filtered with extra L and C. So this analysis is encouraging.

In all of these studies, I never got a shock, never caused a BANG, and never blew up any components or op amps (except when my thumb absent-mindedly nudged a  $\pm 2$ -V supply up to  $\pm 12$  V). So I don't feel bad, figuratively and literally. ■

*RAP/Robert A. Pease/Engineer*

to view this article online,  [click here](#)

[RETURN TO THE TABLE OF CONTENTS]



# What's All This One-Transistor Op-Amp Stuff, Anyhow

*Originally published May 8, 2008*

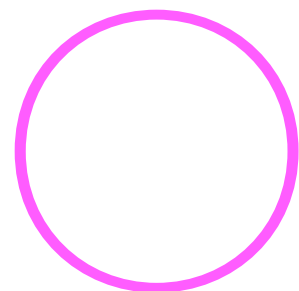

One day, back about 1966, I was going up the elevator at 285 Columbus Avenue in Boston to look at some production problems on Philbrick's fifth floor. And who was in the elevator, but George Philbrick's friend Jim Pastoriza.

Jim was going up to show George his new analog computer demonstrator—portable and battery-powered. In fact, it was running, and he gave me a demo right on the elevator as we ascended. And, this modular analog computer ran on a couple of Jim's new one-transistor op amps.

This is not an April Fool's joke. This is not a hoax

## What's All This One-Transistor Op-Amp Stuff, Anyhow?

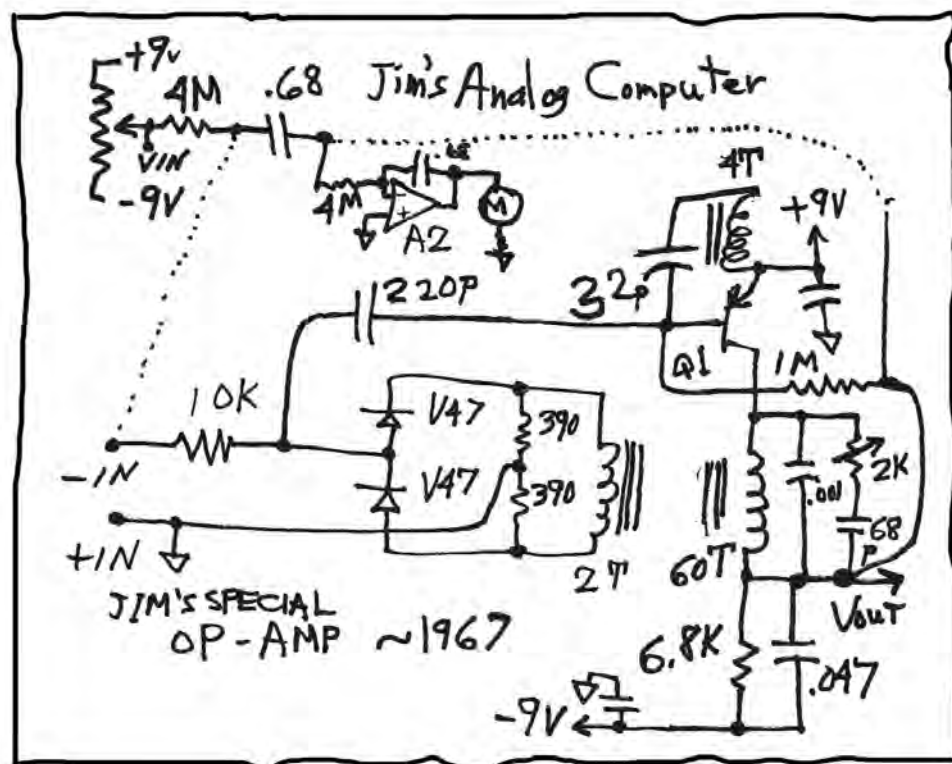

(see the figure). I don't think anything ever came of that amplifier, though. Nobody else ever heard of it. It was never published. It was obviously the result of some kind of a bar bet. George must have bet a big bar bill on whether such an amplifier could be built. And Jim was gonna win the bet!

### History Almost Repeats Itself

I did see the schematic of that amplifier, and it was very much like the one shown here. But I never did see the internals of the amplifier's construction. Since I just remembered this amplifier

after more than 40 years, I decided to re-create it. I got a group of likely looking transformers and tried to get them to ring when tickled. They would not ring with any decent Q when tuned with 1000 pF.

Finally, a friend had pity on me and loaned me a good, small (1.1-in.) Carbonyl C toroid. (Carbonyl is pure iron in powder form, embedded in a neutral matrix.) When wound with 60 turns, it had good Q. I put on a few more turns and lashed it into the circuit shown. It oscillated nicely at 0.7 MHz, using a 2N3906. (Jim had used a 2N384-type, which is a little hard to find these days.)

Then I added in the galvanically isolated “front end” with the V47 varactors, with the 220-pF feedback to the base of the PNP. I was able to wiggle the dc voltage at the negative input and modulate the amplitude of oscillation—and to move the dc output voltage a little. I fooled around with various variable capacitors, and trimpots, too, and twisted-pair capacitors. I got the “gain” up to 0.2 and then 0.4.

I borrowed our best “twiddle box” and it helped, as the capacitor had a knob on it. The 1.9k in series with 68 pF was

## What's All This One-Transistor Op-Amp Stuff, Anyhow?

rather touchy, but I got the gain up to 12. Then I added a little PFB with the 24k/5k divider. (I could get high gain in a small region, but it was not very linear, and even then, it had good high gain mostly when VOS was as gross as 0.5 V.) Finally, I got the gain error down to  $\pm 0.1$  V for a  $\pm 1$ -V output swing.

Jim had said his gain was up at 1000. I was hoping I could get the gain up to 100, but none of my tricks could get it up there. Jim was a good engineer, and he knew a lot about varactor amplifiers, but maybe he never really got it to 1000. But it works okay even with a gain of 20.

### The Results

---

Anyhow, I set up the big one-transistor kluge along with another low-power FET op amp as "A2" and ran them as an analog computer as Jim had showed me on the elevator. If you look at the output of A2, it starts out pegged. If you turn the  $V_{IN}$  pot, you can bring the meter to a balanced state, but it's moving

fast. Can you manipulate that pot to get and keep the meter on-scale? After you understand that this is simply a double integrator, and after you practice a bit, it's not very hard.

So, here is a little analog computer that you can use to practice closing the loop around a double integrator. And now you see that a one-transistor amplifier is not a hoax! Improbable, yes, but usable in a pinch. I haven't given up on getting good gain, but I'll spend no more time on it for now.

One of my friends reminded me that there's one thing worse than a circuit with too many transistors, and that's a circuit with too few transistors. Yeah, that's true. But back in 1966, using a small number of those expensive transistors wasn't a terrible idea. If I could only get the gain a little higher! ■

*RAP/Robert A. Pease/Engineer*

to view this article online,  [click here](#)

[RETURN TO THE TABLE OF CONTENTS]



# What's All This Bridge Amplifier Stuff, Anyhow

*Originally published June 11, 2009*

I was helping some engineers working on a strain-gauge preamp not too long ago. We had it functioning, but there seemed to be some bad linearity problems. We even set up a little calibrator and tried to get it linear, yet we kept getting odd errors, using the conventional amplifier setup per Figure 1.

The guys said, “We don’t have to worry about precision or calibration because we’re calibrating it in software.” I went in with a digital voltmeter (DVM) and started measuring real signals.

One of the major problems turned out to be the zero-point calibration. The strain-gauge was nicely trimmed for zero output at zero force, and the first preamps (LMP2022) had zero output. But

## What's All This Bridge Amplifier Stuff, Anyhow?

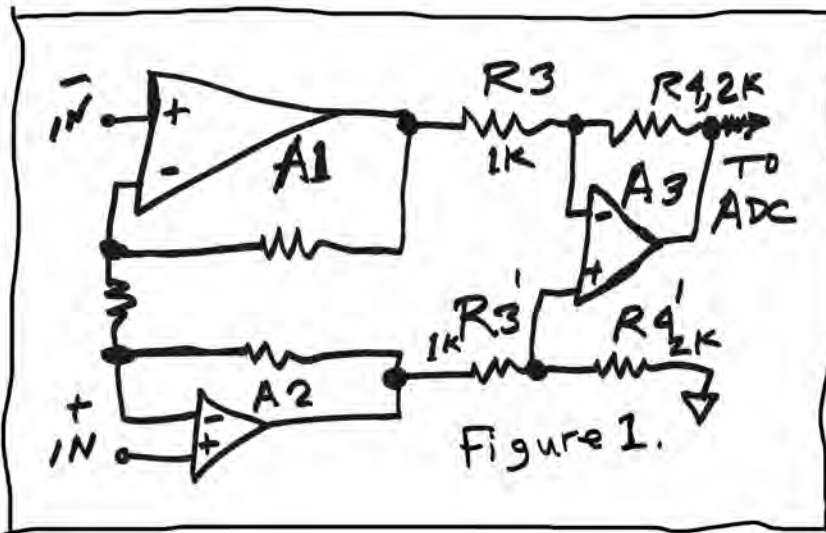

the second amplifier stage output was then nowhere near ground.

Oh, yeah. They had been using the third amplifier as a “rail-to-rail” amplifier. These so-called “R/R” amplifiers don’t really go to the rail, though. Maybe within 10 or 25 mV? It turned out there were three problems.

### THREE PROBLEMS

First, to run the third amplifier, they set up its input/ feedback resistors as 1k/2k. They woulda been a little better off at 100k/200k. Second, the amplifier won’t go to the rail, but just close. And third, they had put in the resistors at 1%. They were still saying, “We don’t need precision amplifiers or resistors, as we’ll be calibrating in software.”

I’m beginning to get grouchy about such people. I explained that using 1%

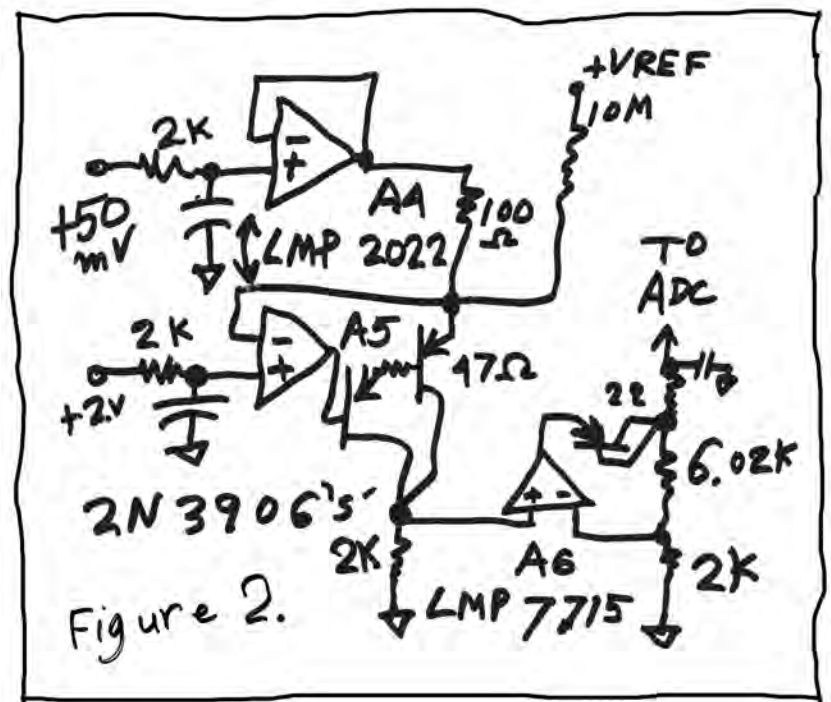

resistors, the common-mode rejection ratio (CMRR) of the third amplifier can be as poor as 37 dB with respect to the input or 31 dB at the output. They said they were assuming there would not be much CM noise.

I pointed out that that’s not a safe assumption. Plus, the center of the bridge is at about 2.2 V, so there’s 1.5 V of VCM. Using 1% resistors, the output may go to +60 mV or –60 mV, per my comments on error budget (see “*What’s All This ‘Error Budget’ Stuff, Anyhow?*”). Since there’s no way the output can go to –60 mV, this is doomed! What if we put in a couple bucks to buy 0.1% resistors? The whole project is still in trouble. Now jump to Figure 2, which is based



## What's All This Bridge Amplifier Stuff, Anyhow?

on my error budget circuits.

Input differential voltages from 0.00 to 50.0 mV will be converted to a current, which flows through the Darlington, down toward ground, with 0.01% accuracy and even better linearity. The op amps' low (5  $\mu$ V) offsets will provide very good precision. Then A6 (LMP7715) can easily magnify the signal up to the +4.0-V input that the analog-to-digital converter (ADC) would like to see. And the whole thing will swing close to ground.

So even in real-world conditions, we don't have to "assume" that an "R/R" amplifier can "swing R/R." It takes good strategy to get this. And now, the "software calibration" will surely work well. So the engineers said, "Good! Now we are ready to do 11 and 12 bits of accuracy and resolution!"

I responded, "Like heck you are! Show me the error budget on your  $V_{REF}$ , which as a bandgap surely has a lot of voltage noise!" We went over this and

added some filtering. And, we put the same amount of filtering on the signal fed to power the bridge. They finally figured out that wishful thinking does not lead to good S/N. Good engineering can.

One of the engineers said, "It looks like you're just solving the problems by throwing a lot of silicon at the problem." I pointed out that the silicon is very cost-effective. It's the screw-ups that are expensive, as well as the ability to get something good enough to ship consistently. "It's bad product design that's expensive," I said.

I may no longer work full-time for NSC, but I know how to use good NSC amplifiers to do precision work—not just wishful. ■

*RAP/Robert A. Pease/Engineer*

to view this article online,  [click here](#)

[RETURN TO THE TABLE OF CONTENTS]



# What's All This Best Amplifier Stuff, Anyhow

*Originally published December 8, 2009*

**A**fter I wrote up that amplifier scheme (see “*What’s All This Bridge Amplifier Stuff, Anyhow?*”), I was thinking about how to get better common-mode (CM) range.

That June 11 amplifier had excellent CM accuracy, but darned little CM range, about +1.9 V to perhaps +2.6 V, which was adequate only for the 4.4-V bridge shown there. What if you want a CM range of  $\pm 2$  or 4 or 7 or 10 V? That amplifier was hopeless, but let’s consider the CM extender circuits (see *the figure*).

As the CM voltage goes up and down, A1 acts as a simple follower/buffer and bootstraps the powersupply voltage of the next stages. So, A2

## What's All This Best Amplifier Stuff, Anyway?

and A3 have basically a constant CM voltage. They have to worry very little about changes in  $V_{CM}$ .

Thus, the common-mode rejection ratio (CMRR) can be very good. A6 is set up to bring the outputs of A2 and A3 down to ground. A6 will almost always need a CMRR trim, because the resistors R3, R4 aren't accurate enough. So, P1 is shown.

## THE PREFERRED EMBODIMENT

If I were a patent freak, I would tell you my “preferred embodiment” of this circuit. The first example is: A1 = LF411; A2 and A3 are the LMP2022 as shown in June 11, and A4 and A5 are LM7332. A6 could be another LF411, or almost any amplifier.

Let's choose  $R1 = 100$  and  $R2, R3 = 10k$ , so the first stage has a gain of 201. This can give very low dc offset and drift. The two zeners can be any 2.5-V zener, such as the LM4040-2.5, to give the first amplifier a 5-V total supply voltage. The total CM range is about +12 V to -10 V.

But actually, while the LMP2022s provide excellent dc drift, this composite amplifier doesn't have very low noise for low source impedances. I mean, you can put in almost any type of op amp as

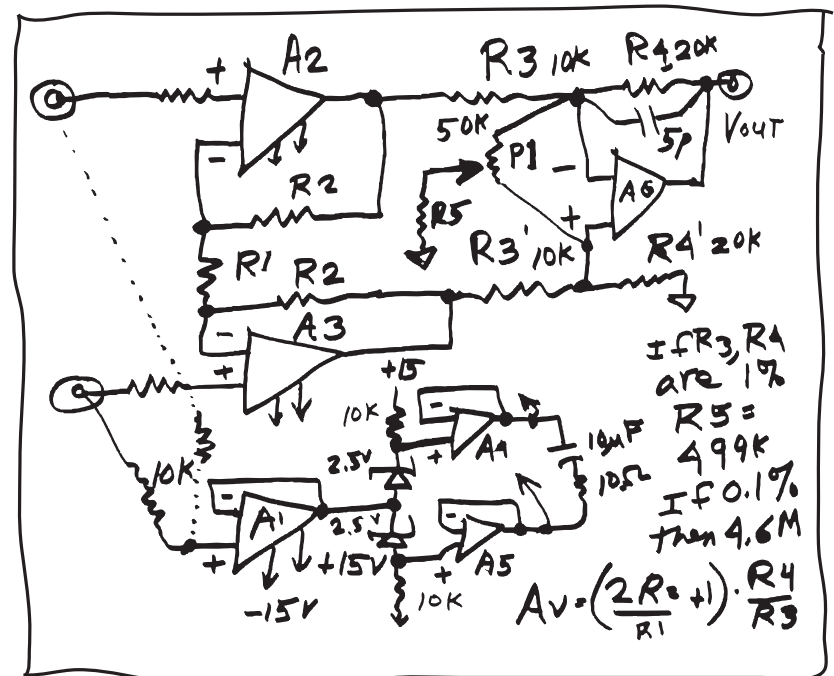

A2 and A3. So, your “preferred embodiment” could put in a couple LMH6624s and get very low voltage noise, such as 1.4 nV/Hz, total for the whole circuit, assuming your  $R_S$  is lower than 200 .

Specifically, I can never tell you what is the “best” low-noise op amp for your application, until you tell me your  $R_S$  and your desired bandwidth and your signal size. As in any amplifier, you have to engineer it for best results, planning for the  $R_S$  and those other factors.

So if you want to go to high impedance, you could choose an LMC662, which has 5 fA of  $I_B$  and  $Z_{IN}$  better than  $10^{14}$  . Maybe  $10^{16}$  The noise voltage is ~22 nV/Hz per amplifier. Or, the LMV651 offers only slightly worse  $I_B$  but

## What's All This Best Amplifier Stuff, Anyhow?

6.5 nVHz. In other words, you can use almost any kind of amplifier, and you choose suitable types—as you always have to!

### OTHER CONSIDERATIONS

- High bandwidth: You might want to take a gain of more like 21 in the first stage and 10 in the later stage. Use fast amplifiers.
- High gain: maybe a gain of  $201 \times 100$ ?
- High CMRR: You will normally need to trim because the output resistors R3, R4 aren't perfect. 1% resistors will prevent you from getting more than about 130 dB (referred to input) with your best trim. Using 0.1% resistors for R3, R4 can get your trim range smaller so you can get 150 dB. Anything more than that, and you have to engineer it. You may be able to get up to 120 or 130 dB without a pot. Refer to my LB-46 (see [www.national.com/an/LB/LB-46.pdf#page=1](http://www.national.com/an/LB/LB-46.pdf#page=1)).
- Fast CM signals? A1, A4 and A5 will

have to have high slew rate, and you'll have to test for that.

- High output drive? Put a buffer inside the output loop of A6.
- Large input signals, larger than a volt? You may need the floating supply pushed up from  $\pm 2.5$  to  $\pm 5$  V or more and use higher-voltage amplifiers for A2 and A3.
- Strange CM ranges? Well, you could run the whole amplifier on +20 and -10 V, or +5 V and -25 V, to get an asymmetrical CM range.

Have I built this? Well, mostly in my head, as a paper study. The road to Santa Clara is paved with good intentions. When I realized I would have to build several circuits to evaluate, I just got intimidated and built none of them. But it's still a good framework for almost any strange or wild set of bridge-amplifier features you may want. Have a ball! ■

*RAP/Robert A. Pease/Engineer*

to view this article online,  [click here](#)

[RETURN TO THE TABLE OF CONTENTS]



# What's All This Profit Stuff, Anyhow

*Originally published November 28, 2011*

**H**ere's another *esaeP's Fable*. The class of 1966 was starting to plan its 25th Reunion. The Reunion Committee went around and contacted all the alumni, until they came to Joe. Joe, as duly noted in the Yearbook, was the Person Least Likely to Succeed in business. That had been a clear choice, back in 1966—everybody recognized that Joe was a klutz, with no sense of proportion, no head for math nor business. But Joe had filled in his questionnaire: President and CEO of Widget Enterprises—a multi-billion dollar multi-national corporation. And Joe had just donated a new Library to the Business School. How could this be? So it was with great respect and curiosity

## What's All This Profit Stuff, Anyhow?

that the Reunion Committee invited Joe to give the key-note address at the Reunion.

It was the same old Joe who stood up to give the speech at the reunion. “I never was much of a speech maker. And I don’t have any big secrets about how I do business. I just buy widgets for \$1.00, and I sell them for \$10.00. I’m perfectly happy to take just a 10% profit. *End of Fable.*”

When I started work at George A. Philbrick Researches in 1960, I observed a secret project going on—a “skunk-works” project to bring out Philbrick’s first solid-state operational amplifier. Technicians were testing and grading diodes and transistors, night and day, to generate matched pairs. The data sheet was being rushed to completion. Test engineers were learning how to measure currents in the picoampere range. And Sales hopes to sell a few of these P2 amplifiers, at a selling price of \$185, to pay for all this research effort.

Wow. An op amp with just 100 picoamperes input current—with no tubes, no heater power, no mechanical choppers. That must use the finest new silicon transistors. No wonder it sells for \$185. But when I got to know the senior engineer, Bob Malter, a little better, he showed me that there were not any sil-

icon transistors in the P2. There were just 7 little germanium transistors in there. What? WHAT??

When Bob Malter arrived at Philbrick Researches in Boston in 1957, he was already a smart and accomplished engineer. After designing several analog computer modules (which were the flagships of the Philbrick product line) he became intrigued with the concept of the Varactor amplifier, just about the time that George Philbrick, the founder and chief Research Engineer, was getting frustrated.

George had been trying to make a parametric amplifier, using varactor diodes and germanium transistor amplifiers. When the bridge started out balanced, just a few millivolts of dc input could cause enough imbalance to be amplified and then rectified (synchronously) to drive a dc amplifier. In theory, you could make an operational amplifier that way. But George had worked for many months on an elegant design he called the P7. It used 14 germanium transistors, in a little cordwood assembly with 8 little pc boards packed in between 2 mother boards. He could not get good repeatable results, not for dc accuracy or dynamics or temperature shift.

Now, Bob Malter was a very pragmat-

## What's All This Profit Stuff, Anyhow?

ic, hard-headed engineer. You would not want to bet him that he could not do something, because he would determinedly go out and do it, and prove that he was right—and that you were wrong. Bob had his own ideas about how to simplify the P7, down to a level that would be practical—which he called the P2. I do not know how many false starts and wild experiments Bob made on the P2, but when I arrived at Philbrick as a green kid engineer in 1960, Bob was just getting the P2 into production.

Instead of George's 10 pc boards, Bob had put his circuits all on just two pc boards that lay back-to-back. Instead of 14 transistors, he had a basic circuit of 7 transistors—just one more device than the little 6-transistor AM radios of the day. He actually had 2 little transformers—one to do the coupling from the 5-MHz oscillator down into the bridge, and one to couple out of the balanced bridge into the first of four RF amplifier stages. (If you are really interested in the complete schematics of the P2 and P7, and other technical comments and details you will want to buy Jim Williams' book.\*) Note, 25 years ago, these would have been the center of fantastic technical espionage; but today, it's just a matter of historical curiosity—industrial archaeology—on an ob-

solete product. You can't buy the parts to make these amplifiers any more, and even when you could, you could build a circuit to follow the schematic, and it wouldn't work.

So what's the big deal? Here's a pretty crude operational amplifier with a voltage gain of 10,000, and an output of  $\pm 1$  mA at  $\pm 10$  volts, with a vicious slew rate of 0.03 volts per microsecond. Who would buy an amplifier like that??? It turned out that thousands and THOUSANDS of people bought this amplifier, because the input bias current at either input was just a few picoamperes. *Picoamperes?* What the heck is a *picoampere*? Most electrical engineers in 1960 didn't even know what a picofarad was, not to mention a picoampere, but, they figured out it was a heck of a small fraction of a microampere. And for many high-impedance instrumentation applications, the P2 was clearly the only amplifier you could buy that would do the job. And it had this low bias current, only a few picoamperes, because all those germanium transistors were running at 5 Mcps, and their 5 or 10  $\mu$ A of dc base current had no effect on the precision of the input current.

The input current was low, thanks to a well-matched bridge of four V47 vari-caps. These were sold by Pacific Semi-

## What's All This Profit Stuff, Anyhow?

conductor Inc. (PSI) for use as varactors in parametric amplifiers, up in the hundred of “Megacycles.” The “V47” designation meant that they had a nominal capacitance of 47 pF at 4-V reverse bias, which is where most RF engineers would bias them. But Bob Malter biased them right around 0 Vdc, with a miniscule  $\pm 60$  mV of ac drive. At this bias, the capacitance was 110 pF plus 1 pF per 20 mV—not an extremely high gain slope.

At this level of drive, each diode would only leak 20 or 40 pA. But Bob had a gang of technicians working day and night to match up the forward conduction characteristics and the reverse capacitance voltage coefficients, and he was able to make sets of 4 varactors that would cancel out their off-set drift versus temperature, and also their reverse leakage. Of course, there was plenty of experimenting and hacking around, but eventually a lot of things worked OK. After all, when you buy 10,000 V47s, some of them have to match pretty well.

So here's a little do-hickey, a little circuit made up of just about as much parts as a cheap \$12 transistor radio, but there was quite a lot of demand for this kind of precision. How much demand? Would you believe \$227 of de-

mand? Yes! The P2 originally started out selling for \$185, but when the supply/demand situation heated up, it was obvious that at \$185, the P2 was underpriced. So the price was pushed to \$227, to ensure that the people who got them were people who really wanted and needed them.

Meanwhile, what other kinds of “transistorized” op amps could you buy? Well, by 1963, for \$70 to \$100, you could buy a 6- or 8-transistor amplifier, with  $I_{bias}$  in the ballpark of 60,000 to 150,000 pA, and a common-mode range of 11 V. The P2 had a quiet stable input current guaranteed less than 100 pA (5 or 10 pA typical), and a common-mode range of  $\pm 200$  V. (After all, with transformer coupling, the actual dec level at the balanced bridge could be at any dc level so there was no reason the CMRR could not be infinite.)

Wow! A \$227 *gouge*. (You couldn't call it a “rip-off” because the phrase hadn't been invented, but perhaps that is the only reason....) Obviously, this must be a very profitable circuit. Every competitor—and many customers—realized that the P2 must cost a rather small amount to build, even allowing for a few hours of work for some special grading and matching and testing. So, some people would invest their \$227



## What's All This Profit Stuff, Anyhow?

and buy a P2 and take it home and pull it apart and try to figure out how it worked. The story I heard was that one of our competitors hired a bright engineer and handed him a P2 and told him, “Figure out how they do this. Figure out how we can do it, too.” In a few days he had dismantled the circuit and drawn up the schematic. Then he analyzed it, and began experiments to be able to meet or exceed the P2’s performance. But he couldn’t get it to work well. He tried every approach, but he never could. After a full year, they gave up.

You see, it turns out there was some interaction between the input of the first RF amplifier and the output of the 4th amplifier, that made the P2 work, when you assembled the two pc boards close together. It would not work with any other layout, orientation, or circuit-assembly technique. So none of our competitors ever second-sourced the P2. And the P2 and P2A and SP2A remained profitable and popular even when the new FET-input amplifiers came along at much lower prices. It was years later before these costly and complex parametric amplifiers were truly and finally obsolete by the inexpensive monolithic Bifet amplifiers from National Semiconductor and other IC makers. Even then, the FET amplifiers could not compete

when your instrument called for an op amp with a common-mode range of 50 or 200 V.

Still, it is an amazing piece of history, that the old P2 amplifier did so many things right. It manufactured its gain out of thin air, when just throwing more transistors at it would probably have done more harm than good. And it had low noise, and extremely good input current errors—traits that made it a lot of friends. The profits from the P2 were big enough to buy Philbrick a whole new building down in Dedham, Massachusetts, where Teledyne Philbrick is located to this day (notwithstanding a recent name change to Teledyne Components). And the men of Philbrick continued to sell those high-priced operational amplifiers, and popularized the whole concept of the op amp.

Then when good low-cost amplifiers like the UA741 and LM301A came along, they were readily accepted by most engineers. Their popularity swept right along the path that had been paved by those expensive amplifiers from Philbrick. If George Philbrick and Bob Malter and Dan Sheingold and Henry Paynter and Bruce Seddon hadn’t written all those applications notes and all those books and stores, heck, Bob Widlar might not have been

## What's All This Profit Stuff, Anyhow?

able to give his UA709s and LM301a away! And the P2—the little junk box made up virtually of parts left over from making cheap transistor radios—that was the profit engine that enabled and drove and powered the whole operational-amplifier industry.

One time, I was standing around in front of the Philbrick booth at the big IEEE show in New York City. A couple engineers were hiking past the booth, and one said to the other, nodding his

head towards the booth, "...and there's the company that makes a big bloody profit...." Well, at that time George A. Philbrick Researches was indeed making big profits from the P2. We could never deny that. Just like Joe and his widgets. ■

*RAP/Robert A. Pease/Engineer*

to view this article online,  [click here](#)

[RETURN TO THE TABLE OF CONTENTS]

# GET MORE IDEAS AND SOLUTIONS FROM **ELECTRONIC DESIGN** NOW!

*From the start of your design idea, sketched as a schematic on a napkin, through to the ordering process for prototypes and final production ...*



*Electronic Design* is the design engineer's trusted online resource.

If you like the content of this eBook, you'll love what we have for you on the websites!

*Go to next page to see what we offer!*

**Electronic  
Design.**

# CHECK OUT THESE RESOURCES FROM ELECTRONIC DESIGN AND OUR SISTER BRANDS

## WEBSITES

**Electronic Design** **Microwaves & RF**

**sourceesb**

**Power Electronics**

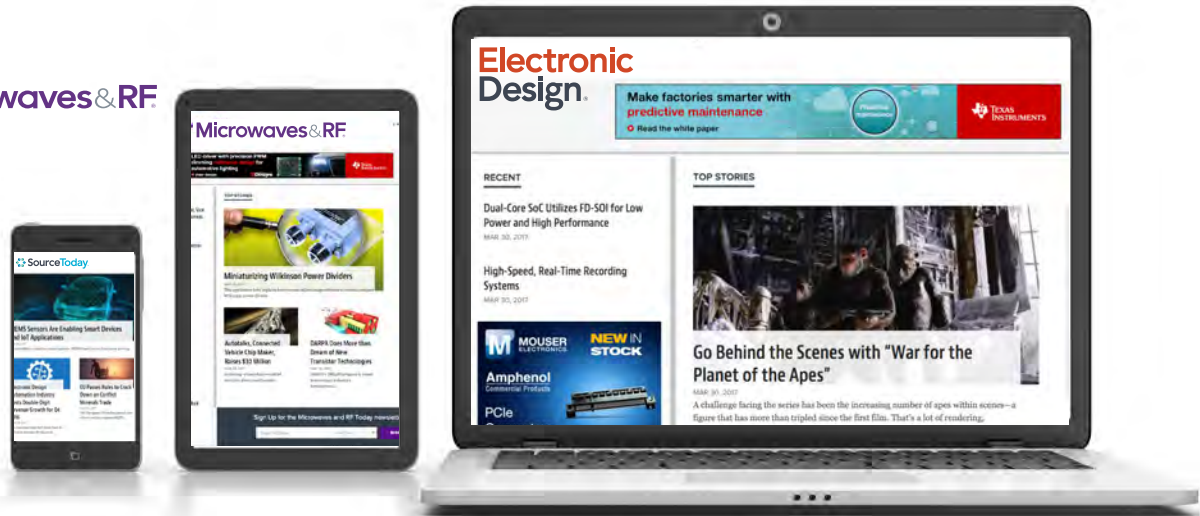

## MAGAZINES

You can also apply for a subscription to one of our traditional magazines available in both print and digital formats.

**ELECTRONIC DESIGN – complimentary in US and Canada -  Subscribe Now**  
*Non-qualified or Outside the US and Canada:* you will be prompted to pay based on your location.

**MICROWAVES & RF – complimentary internationally-  Subscribe Now**  
*Non-qualified:* you will be prompted to pay based on your location.



## NEWSLETTERS

Stay current with the industry with newsletters created by engineers and editors with inside connections! You'll find coverage on a wide variety of electronics technologies from Analog & Mixed Signal to Embedded and more.

 **Click Here** to check out what more than 200,000 engineers are reading now.



## ABOUT US

Going strong since 1962, *Electronic Design* is the premier information source for electronics engineers. We provide must have, fully comprehensive coverage of the electronics industry through a vast network of experts. *Electronic Design* covers the technologies required for engineers to make the right design decisions at the right time – quickly and efficiently.

